



# **RECOMMENDED PRACTICES MANUAL**

## **A GUIDELINE FOR MAINTENANCE AND SERVICE OF UNPAVED ROADS**

**CHOCTAWHATCHEE, PEA and YELLOW RIVERS  
WATERSHED MANAGEMENT AUTHORITY  
FEBRUARY 2000**

# **RECOMMENDED PRACTICES MANUAL**

## **A GUIDELINE FOR MAINTENANCE AND SERVICE OF UNPAVED ROADS**

**CHOCTAWHATCHEE, PEA and YELLOW RIVERS  
WATERSHED MANAGEMENT AUTHORITY  
FEBRUARY 2000**

## **ACKNOWLEDGMENTS**

This manual is the realization of the vision and effort of a group of men and women committed to preserving and enhancing the quality of our water resources, and the environment in general, while improving the methods of maintaining our unpaved public road infrastructure. Their endeavor has been to incorporate a new way of thinking. This is being done by introducing new ideas and innovations to effect positive changes from traditional approaches to unique and even revolutionary approaches toward maintaining our unpaved roads and ditches. Paramount to this has been educating our society of the need for enhanced environmental sensitivity.

While many have been pro-active in this endeavor, special recognition is given to Mr. Joe K. Parker, Chairman, Choctawhatchee, Pea and Yellow Rivers Watershed Management Authority for his tenaciousness in addressing unpaved roadway problems and in energizing the CPYRWMA to be pro-active in taking the initiative to help solve these problems. Acknowledgment is also due Mr. H. Estus Walker, former Executive Director, in his active leadership and skill spearheading the initiative, consolidating the necessary resources, and putting into motion events which led to the publishing of this manual.

A special thanks to all those professionals and laymen who gave of their time, shared their knowledge and experience, and shared their ideas to help make this a manual a reality.

The research, assemblage, and compilation of the text, figures, and photographs contained within this manual was performed under contract between the Choctawhatchee, Pea and Yellow Rivers Watershed Management Authority and Polyengineering, Inc., Dothan, Alabama. Gene Kearley, P.E. was the author and project manager, assisted by Lawrence McCallister, P.E. as principal engineer.

## **DISCLAIMER**

This manual does not constitute a standard, specification, or regulation bound on any professional group or political entity, but is intended only as a guide.

# TABLE OF CONTENTS

---

<b>INTRODUCTION</b> .....	vii
---------------------------	-----

## **CHAPTER 1**

<b>Road Surface</b> .....	<b>1</b>
---------------------------	----------

<b>Description</b> .....	1
--------------------------	---

<b>Importance to Maintenance &amp; Water Quality</b> .....	1
--	---

<b>Surface Profile, Grading, and Drainage Characteristics</b> .....	1
---	---

<i>General</i> .....	1
----------------------	---

<i>Performance</i> .....	3
--------------------------	---

Blading and Dragging .....	3
----------------------------	---

Reconstructive Grading .....	4
------------------------------	---

<b>Distress Conditions</b> .....	6
----------------------------------	---

<i>Surface Deteriorations</i> .....	6
-------------------------------------	---

Dust .....	6
------------	---

Ravelling .....	7
-----------------	---

Slipperiness .....	7
--------------------	---

<i>Surface Deformations</i> .....	7
-----------------------------------	---

Rutting .....	7
---------------	---

Corrugating/"Washboarding" .....	8
----------------------------------	---

Depressions .....	8
-------------------	---

Potholes .....	8
----------------	---

Softspots .....	8
-----------------	---

<i>Storing and Stockpiling Soil Materials</i> .....	9
---	---

## **CHAPTER 2**

<b>Ditches</b> .....	<b>11</b>
----------------------	-----------

<b>Description</b> .....	11
--------------------------	----

<b>Importance to Maintenance &amp; Water Quality</b> .....	11
--	----

<b>Ditch Profile and Grading</b> .....	11
--	----

<i>General</i> .....	11
----------------------	----

<i>Other Applications</i> .....	13
---------------------------------	----

<i>Cleaning and Maintenance</i> .....	13
---------------------------------------	----

# TABLE OF CONTENTS (cont.)

---

## CHAPTER 3

<b>Culverts</b> .....	<b>15</b>
<b>Description</b> .....	15
<b>Importance to Maintenance &amp; Water Quality</b> .....	15
<b>Culvert Profile</b> .....	15
<i>General</i> .....	15
<i>Maintenance At Sensitive Aquatic Environment Crossings</i> .....	17
<i>Culvert Installation/Replacement</i> .....	19
<i>Head Walls (Headers)</i> .....	19
<i>Cleaning and Maintenance</i> .....	20

## CHAPTER 4

<b>Outlet Structures</b> .....	<b>21</b>
<b>Description</b> .....	21
<b>Importance to Maintenance &amp; Water Quality</b> .....	21
<b>Location</b> .....	21
<b>Implementation</b> .....	21
<i>Structures</i> .....	21
Splash/Stilling/Plunge Basin .....	21
Splash Apron .....	22
Drop Box/Manhole .....	23
Stilling Well .....	23

## CHAPTER 5

<b>Bank Stabilization</b> .....	<b>25</b>
<b>Description</b> .....	25
<b>Importance to Maintenance &amp; Water Quality</b> .....	25
<b>Implementation</b> .....	26
<i>Construction and Grading/Re-grading</i> .....	26

# TABLE OF CONTENTS (cont.)

<i>Bank Grading Techniques</i> .....	26
Terracing .....	26
Cutting and/or Filling .....	27
Keying .....	27
Counter-weighting .....	27
<i>Vegetation by Grass Seeding</i> .....	28
<i>Vegetation by Trees &amp; Shrubs</i> .....	29
Live Stakes .....	29
Live fascines/wattle/bundles .....	29
Brush Layering .....	30
Sprigs/plugs .....	31
<i>Structures</i> .....	31
Gabion Retaining Wall .....	31
Vegetated Gabion Retaining Wall .....	32
Log or Timber Crib Retaining Wall .....	32
Mechanical Riprap Revetment .....	33
Vegetated Riprap Revetment .....	34
Mats and Blankets .....	34
Geotextiles .....	35

## CHAPTER 6

<b>Sediment and Erosion Control Tools</b> .....	<b>37</b>
<b>Description</b> .....	37
<b>Importance to Maintenance &amp; Water Quality</b> .....	37
<b>Implementation</b> .....	38
<i>Structures</i> .....	38
Hay Bale Dikes .....	38
Silt Fence .....	39
Rock Ditch Check/Check Dam .....	40
Level Spreader .....	41
Log and Brush Check Dam .....	42
Sediment Trap .....	43
Sediment Basin .....	43
Riparian Buffer .....	44

# TABLE OF CONTENTS (cont.)

---

## CHAPTER 7

<b>Other Considerations</b> .....	<b>47</b>
<i>Aesthetics</i> .....	47
<i>Roadside Debris</i> .....	47
Manmade Material .....	47
Natural Material .....	47
<i>Roadside Vegetation Management</i> .....	48
<i>Retaining Walls and Headwalls</i> .....	48
Beavers .....	48
<b>RESOURCE LIST</b> .....	<b>49</b>
<b>GLOSSARY</b> .....	<b>51</b>
<b>BIBLIOGRAPHY</b> .....	<b>59</b>

---

## FIGURES

---

<u>No.</u>	<u>Caption</u>	<u>Page</u>
1-1	<i>Typical Sections - Unpaved Roadway</i> .....	2
1-2	<i>Blading</i> .....	3
1-3	<i>Blading on Hill Crests and in Valleys or Swags</i> .....	4
1-4	<i>Grading Tools</i> .....	5
1-5	<i>False Ditch</i> .....	5
1-6	<i>Aggregate Comparison</i> .....	6
1-7	<i>Soil Material Storage Site Configuration</i> .....	9







---

## FIGURES (cont.)

---

No.	Caption	Page
2-1	<i>Hillside Pitch of Roadway and Proper Ditch Location</i> . .	11
2-2	<i>Common Ditch Shapes</i> . . . . .	12
2-3	<i>Typical Locations for “Turnouts” and “Tail Ditches”</i> . .	12
3-1	<i>Examples of Fish Friendly Designs</i> . . . . .	18
4-1	<i>Depressed Type Plunge Basin Illustration</i> . . . . .	22
4-2	<i>Weir-formed Plunge Basin Illustration</i> . . . . .	22
4-3	<i>Splash Apron Illustration</i> . . . . .	22
4-4	<i>Drop Box/Manhole Illustration</i> . . . . .	23
4-5	<i>Stilling Well Illustration</i> . . . . .	24
5-1	<i>Slope Terracing</i> . . . . .	26
5-2	<i>Slope Shaping by Cutting and/or Filling</i> . . . . .	27
5-3	<i>Slope Keying for Fill Placement</i> . . . . .	27
5-4	<i>Counter-weighting Toe of Slope</i> . . . . .	27
5-5	<i>Live Stake Planting</i> . . . . .	29
5-6	<i>Live Fascines/Wattles/Bundles</i> . . . . .	30
5-7	<i>Brush Layering Details</i> . . . . .	30
5-8	<i>Sprig/Plug Planting</i> . . . . .	31
5-9	<i>Gabion Retaining Wall</i> . . . . .	31
5-10	<i>Vegetated Gabion Retaining Wall</i> . . . . .	32
5-11	<i>Log or Timber Crib Retaining Wall</i> . . . . .	32
5-12	<i>Mechanical Riprap Revetment</i> . . . . .	33
5-13	<i>Vegetated Riprap Revetment</i> . . . . .	34
6-1	<i>Hay Bale Dikes</i> . . . . .	38
6-2	<i>Silt Fence Details</i> . . . . .	39
6-3	<i>Rock Ditch Check/Check Dam Details</i> . . . . .	40
6-4	<i>Level Spreader Details</i> . . . . .	41
6-5	<i>Log and Brush Check Dam Details</i> . . . . .	42
6-6	<i>Sediment Basin Illustration</i> . . . . .	44
6-7	<i>Riparian Buffer Illustration</i> . . . . .	45



# INTRODUCTION

## **Funding Source**

Partial funding for this manual is provided by a grant from the U.S. Fish and Wildlife Service, U.S. Environmental Protection Agency through a Clean Water Act, Section 319 grant to the Alabama Department of Environmental Management, the southeast Alabama County Commissions of Barbour, Coffee, Covington, Crenshaw, Dale, Geneva, Henry, Houston, and Pike Counties; and the Choctawhatchee, Pea and Yellow Rivers Watershed Management Authority, an agency of the State of Alabama. The funds are administered by the Choctawhatchee, Pea and Yellow Rivers Watershed Management Authority.

## **Participants**

The following organizations, groups, and individuals have provided valuable service and information for the development of this manual:

Paul Kennedy, Coordinator, CAWACO RC&D

Mike Mullen, Director, Center for Environmental Research and Service, Troy State University  
U.S. Fish and Wildlife Service

Barbour County, AL Commission and County Engineer's Office

Bullock County, AL Commission and County Engineer's Office

Coffee County, AL Commission and County Engineer's Office

Covington County, AL Commission and County Engineer's Office

Crenshaw County, AL Commission and County Engineer's Office

Dale County, AL Commission and County Engineer's Office

Geneva County, AL Commission and County Engineer's Office

Henry County, AL Commission and County Engineer's Office

Houston County, AL Commission and County Engineer's Office

Pike County, AL Commission and County Engineer's Office

## **Purpose**

To provide a written manual of standard procedures which describe and illustrate cost effective techniques and practices which can be used to enhance stability and maintenance of unpaved roadways while reducing sedimentation and improving the quality of surface waters in the Choctawhatchee, Pea and Yellow Rivers Watershed Management Authority (CPYRWMA) counties in south Alabama and northwest Florida. County and City Engineers, road maintenance crews, private companies, lake associations, select Boards and Authorities, and the citizenry of Alabama can effectively use this manual.

## Need

The costs involved in maintenance of unpaved roads is one of the most significant items in the budgets of most southeast Alabama counties. Erosion of unpaved roads and their drainage systems is the single most significant factor affecting maintenance needs and costs involved with these roadway systems. The costs to the counties and local municipalities, due to roadway erosion, is not limited to direct costs associated with keeping these unpaved roads passable, but also include additional costs due to increased flooding, impaired waterway navigation, loss or impairment of stream or lakeside recreational areas, loss of fisheries and other riparian zone natural resources, adverse effects on the natural food chain, and loss of aesthetics which can have profound effects on tourism and general business growth. Most of the latter-mentioned effects are considered in today's social climate to be *environmental* issues, and they are; but rest assured, they are very real economic concerns as well.

Erosion of unpaved roadways occurs when soil particles are loosened and carried away from the roadway base, ditch, or road bank by water, wind, traffic, or other transport means. Exposed soils, high runoff velocities and volumes, sandy or silty soil types, and poor compaction increase the potential for erosion. Loosened soil particles are carried from the road bed and into the roadway drainage system. Some of these particles settle out satisfactorily in the road ditches, but most often they settle out where they diminished the carrying capacity of the ditch, and in turn cause roadway flooding, which subsequently leads to more roadway erosion. Most of the eroded soil, however, ultimately ends up in streams and rivers where it diminishes channel capacity causing more frequent and severe flooding, destroys aquatic and riparian habitat, and has other adverse effects on water quality and water-related activities.

Aggravating causes of erosion on unpaved roadways include erosive road-fill soil types, shape and size of coarse surface aggregate (if any), poor subsurface and/or surface drainage, wet and dry road fill moisture extremes due to atmospheric conditions, freeze/thaw cycles, poor roadbed construction (poor graded material, inadequate compaction), roadway shape, roadway shading/sunlight exposure, traffic parameters such as speed, volume, vehicular weight, and lane patterns, exposed soils, untimely road and drainage system maintenance, excessive off-site runoff, and lack of adequate numbers of runoff discharge outlets (turn-outs) from the roadway. This is not an all-inclusive list of causative factors of erosion; however, it should be enough to make apparent the scope of the problem and the need for a comprehensive, wide-spread, maintenance guideline which incorporates the knowledge and experience of pertinent professionals and skilled laymen from throughout the concerned areas in an effort to reduce roadway maintenance needs and costs through erosion control on unpaved roads. The result will be money freed from maintenance and repair expenditures becoming available for more productive projects such as more substantial roadway improvements, etc., and subsequently, an improvement in the overall economy of the Choctawhatchee, Pea, and Yellow River basins.

# RESOURCE LIST

---

The following agencies and organizations may be able to provide assistance with road maintenance, erosion control, and sedimentation problems within unpaved roadways and associated natural waterways:

County Engineer's Office  
Phone: See local phone directory

National Association of County Engineers  
Phone: (515)684-6928

USDA Natural Resources Conservation Service  
Phone: See local phone directory

Alabama Forestry Commission  
Phone: See local phone directory

Resource Conservation and  
Development Councils  
Phone: See local phone directory

US Forestry Service  
Phone: See local phone directory

Federal Highway Administration  
Phone: (202)347-7267

US Fish and Wildlife Service  
Phone: (850)769-0552

Erosion Control Task Force  
(334)271-7700



# GLOSSARY

---

- Aggregate - any of various loose, particulate materials such as sand, gravel, or pebbles.
- Agradation - The building up or collection of materials on a surface over time, specifically here, the build-up of sediment within a stream or channel.
- Articulated bucket - An excavating bucket hinged and jointed at the end of an operating arm. The operating arm is usually hinged and jointed also to afford the flexibility of movement similar to the human arm and hand.
- Backhoe - a hydraulic excavating machine consisting of a tractor having an attached hinged boom, with a bucket with movable jaws on the end of the boom.
- Backfill - the material used to fill or refill an excavation or to create an embankment, or the act of placing this material.
- Batter- the angle of the front of a retaining structure with respect to a vertical plane.
- Bench - a horizontal or near horizontal surface or step in a slope.
- Berm - a narrow shelf or flat area that breaks the continuity of a slope.
- Binder - a material for holding loose material together, as in a macadamized road.
- Blading - utilizing an earthmoving blade to move loose surface material from high spots and road sides to fill and smooth surface irregularities to restore the crown of an unpaved road without cutting into the crust. Also referred to as dragging. Often incorrectly referred to as “grading”.
- Brush layering - live branch cuttings laid in a crisscross fashion on benches between successive lifts of soil.
- Channel - a natural stream or excavated ditch that conveys water.
- Cohesion - the intermolecular attraction holding particles together in mass.



## GLOSSARY (cont.)

---

- Crib structure - a hollow structure constructed of mutually perpendicular, interlocking beams or elements.
- Crust - The compacted, durable, virtually impermeable layer of an unpaved road which usually lies at or just below the road surface.
- Culvert - usually a factory assembled round-shaped conduit connected together with couplers or bands; it differs from a bridge in that it is usually constructed entirely below the road surface.
- Degradation - the wearing down of a surface by erosion and/or the breakdown of surface materials by the erosive forces of weather and traffic.
- Detention structure - a basin or pond used in managing storm water runoff through temporary holding and controlled release of storm water.
- Detention dam - a dam constructed for the purpose of temporary storage of stream flow or surface runoff and for releasing the stored water at controlled rates.
- Disk harrow - an agricultural implement with spike like teeth or upright disks, drawn chiefly over plowed land to level it, break up clods, root up weeds, etc.
- Ditch front slope - the side slope of a ditch adjacent to the roadway.
- Ditch back slope - the side slope of a ditch opposite the roadway.
- Ditch line - the top edge of a ditch's side slope where runoff falls into the ditch channel.
- Diversion - a channel often with supporting dike on the lower side constructed across or at the bottom of a slope for the purpose of intercepting surface runoff to minimize erosion or to prevent excess runoff from flowing onto lower lying areas.
- Diversion dam - a barrier built to divert part or all of the water from a stream into a different course.

## **GLOSSARY (cont.)**

---

- Dragging - utilizing an earthmoving blade to move loose surface material from high spots and road sides to fill and smooth surface irregularities to restore the crown of an unpaved road without cutting into the crust. Also referred to as blading.
- Embankment - a structure of soil, aggregate, or rock material constructed above the natural ground surface.
- Energy dissipater - a device used to reduce the energy of flowing water.
- Erosion - the wearing away of the land surface by running water, wind, ice, or other geological agents, including such processes as gravitational creep; detachment and movement of soil or rock fragments by water, wind, ice, or gravity.
- Filter strip - a long vegetative planting area used to retard or collect sediment for the protection of watercourses, diversions, drainage basins or adjacent properties.
- Fish habitat - resources and conditions essential for the production of fish including sufficient water quality and quantity, spawning, nursery, rearing and food supply areas - all of which fish depend on directly or indirectly for their processes.
- Gabion - a patented woven wire basket filled with rocks of such size that they do not pass through the openings in the basket; individual baskets are stacked in place like building blocks and filled with rock to form erosion resistant structures.
- Geotextile - synthetic polyethylene fibers manufactured in a woven or loose non-woven pattern to form a blanket-like product. Also called geo-fabric.
- Grading - the cutting through, redistribution, and re-compacting of the road crust, and/or adding new road fill material to obtain the desired roadway shape and profile. This term often incorrectly used when referring to blading.
- Habitat - the environment in which the life needs of a plant or animal are supplied.
- Headwall/Header - structure built at the inlet of a culvert to protect the inlet from erosion.

## GLOSSARY (cont.)

---

- Hydroseeding - sowing of seed by distribution in a stream of water propelled through a hose.
- Joint planting - the insertion of live branch cuttings between openings of rocks, blocks, or other inert materials into the natural ground.
- Live cribwall - a hollow, structural wall formed out of mutually perpendicular and interlocking members, usually timber, in which live branch cuttings are inserted through the front face of the wall into the crib fill and/or natural soil behind the wall.
- Live branch cuttings - living, freshly cut branches of woody shrub and tree species that propagate from cuttings embedded in the soil.
- Live fascines - bound, elongated sausage-like bundles of live cut branches that are placed in shallow trenches, partly covered with soil, and staked in place to arrest erosion.
- Live stake - cuttings from branches which will root and sprout when tamped or inserted into the earth.
- Moldboard - an iron plate attached to a plow share which turns over the earth. The blade of a bulldozer or motor grader.
- Motor grader - a long wheel-base tractor with a long adjustable moldboard blade mounted underneath, forward of the driver's seat, used to construct and smooth flat surfaces especially in building and maintaining roadways.
- Mulch - a natural or artificial layer of plant residue or other materials covering the land surface which conserves moisture, holds soil in place, aids in establishing plant cover, and minimizes temperature fluctuations.
- Permeability - the capacity of a porous rock or sediment to permit the flow of fluids through its pore spaces.
- Plunge pool - a device used to dissipate the energy of flowing water that may be constructed or made by the action of flowing. These facilities may be protected by various lining materials.

## GLOSSARY (cont.)

---

- Pollutant - dredged soil, solid waste, incinerator residue, sewage, garbage, sewage sludge, chemical wastes, biological materials, radio-active materials, heat, wrecked or discarded equipment, rock, sand, dust and industrial, municipal, and agricultural waste discharged into water or air.
- Professional engineer - someone educated and trained with experience in the science of engineering, has passed certification examinations, and is certified by a professional licensing board or organization to practice engineering.
- Retention structure - a natural or artificial basin that functions similar to a detention structure except that it may maintain a permanent water supply.
- Revetment - a retaining wall or other support for a trench wall or embankment. Usually a stone (riprap) facing, but can be concrete, brick, wood, etc.
- Riparian Buffer - a strip of undisturbed vegetation between sensitive areas such as rivers, streams, wetlands, ponds, etc., and areas of land disturbance and/or fallow (bare) ground such as unpaved roads, construction sites, etc.
- Riprap - broken rock, cobbles or boulders placed on earth surfaces, such as the face of a dam or the bank of a stream, for protection against the action of water (waves).
- Road crown - convex section or outline of the road surface.
- Rock apron - erosion protection placed at or below streambed elevation in an area of high velocity flow such a culvert outlet.
- Runoff - the portion of the precipitation on a drainage area that is discharged from the area in stream channels.
- Scarify - to abrade, scratch, or modify the surface; for example, to break the surface of a road with a narrow-bladed implement.
- Sediment - solid material, both mineral and organic, that is in suspension, is being transported, or has been moved from its site of origin by air, water, gravity or ice and has come to rest on the earth's surface either above or below sea level.

## GLOSSARY (cont.)

---

Sensitive Aquatic

Environment

Crossing -

A roadway crossing of a wetland or waterway where special road and/or culvert design is required, by law, to protect, maintain and/or accommodate the environment and migratory habits of certain or numerous aquatic fauna.

Sheet flow -

water, usually storm runoff, flowing in a thin layer over the ground surface.

Slope -

the degree of deviation of a surface from horizontal, measured in a numerical ratio, percent, or degrees; expressed as a ratio or percentage, the first number is the horizontal distance (run) and the second is the vertical distance (rise), as 2:1, 50 percent or 30 degrees.

Soil bioengineering -

use of live, woody vegetative cuttings to repair slope failures and increase slope stability, often combined with inert structures and materials.

Sub-base -

the drainage layer of a road between the surface and the existing ground.

Surface water -

all water the surface of which is exposed to the atmosphere.

Swale -

an elongated depression in the land surface that is at least seasonally wet, is usually vegetated, and is normally without flowing water. Swales conduct storm water into primary drainage channels and provide some groundwater recharge.

Tail Ditch -

See "Turn-out".

Tamp -

to force in or down by repeated, rather light, strokes.

Ten-year frequency

storm -

maximum quantity of water flow per second expected at a particular water crossing, on a statistical average, once every ten years; it has a 10 percent probability of occurring in any given year.

## GLOSSARY (cont.)

---

- Terrace - an embankment or combination of an embankment and channel across a slope to control erosion by diverting or storing surface runoff instead of permitting it to flow uninterrupted down the slope.
- Toe of a slope - base of a slope.
- Tracking - the process of running a tracked vehicle such as a bulldozer over an earthen area. A common practice is to run a dozer up and down a constructed, dressed slope before and/or after seeding and mulching.
- Turn-out - intermittent discharge point in a ditch (most usually a road ditch) where the ditch channel is diverted from its normal profile and tapered out onto an area suitable for the discharge of the ditch water.
- Underdrain - a drain placed beneath the surface of a road.
- Vegetated structures - a structure in which living plant materials, cuttings, or transplants have been integrated into the structure.
- Water quality - a term used to describe the chemical, physical and biological characteristics of water, usually in respect to its suitability for a particular purpose.
- Watershed - the area contained within a divide above a specified point on a stream or lake. Often times called drainage areas, drainage basin or a catchment area.
- Wetland - land that has a wet and spongy soil, as a marsh, swamp or bog.



# BIBLIOGRAPHY

Alabama Soil & Water Committee,  
Montgomery Alabama, *Alabama Handbook  
for Erosion Control, Sedimentation Control,  
and Storm Water management of  
Construction Sites and Urban Areas*, July  
1993.

Center for Environmental Research and  
Service, Troy State University, *Unpaved  
Roads Erosion and Sediment Control  
Conference Manual*, March 1999.

Forest Service Standard Specifications For  
Construction of Road and Bridges, USDA-  
Forestry Service, EM 7720-100  
Washington, D. C. 20012.

George D. Aiken & Northern Vermont  
RC&D Councils, *Vermont Better Backroads  
Manual*, Nov. 1995.

Georgia Soil & Water Conservation  
Commission, *Manual for Erosion and  
Sediment Control in Georgia*, 1996.

*Guidelines For Streambank Restoration*,  
Georgia Soil and Water Conservation  
Commission

National Association of County Engineers,  
Action Guide Volume III-1, *Road Surface  
Management*, 1992.

National Association of County Engineers,  
Action Guide Volume III-8, *Soil Erosion  
and Water Pollution Prevention*, 1992.

National Association of County Engineers,  
*Blading Aggregate Surfaces-Training Guide  
Series*, Reprint 1995.

*Riparian Road Guide: Managing Roads to  
Enhance Riparian Areas*, Terrence Institute  
1994.

U. S. Department of Agriculture, Soil  
Conservation Service, “*Soil Bioengineering  
for Upland Slope Protection and Erosion  
Reduction*”, Engineering Field Handbook,  
October 1992.

U.S. Department of Transportation, Federal  
Highway Admin., *Problems Associated  
With Gravel Roads*, publication FHWA-SA-  
98-045, May 1998.



## *Chapter 7*

# **OTHER CONSIDERATIONS**

---

### **Aesthetics**

Public support and cooperation is very important in implementing and maintaining practices and techniques that preserve roadways and enhance overall environmental conditions. The way things “look” is most often the way the public perceives how well things are being done. Care should be taken in design and construction to blend structures and practices with the natural surroundings or to compliment the natural surroundings in a unique and appealing way.

---

### **Roadside Debris**

---

Trash and natural occurring materials which are out of place and/or are a detriment to the roadway system are often found along unpaved roads. Many unpaved roads exist in low-traffic, sparsely populated areas which attract illegal dumping and do not get wide-spread public attention when maintenance needs arise. This truly creates an eye-sore, but more importantly, it leads directly and indirectly to damage and degradation of the roadway system and to pollutants in the environment.

---

### **Manmade Material**

---

One of the most repugnant eye-sore and detriments are manmade items from bottles and car parts to household appliances and car bodies, and more. Many times these items are dumped along roadways in ditches or other drainage paths which inhibit or redirect runoff which in turn erodes and/or weakens the roadway system.

Promptly haul away or properly bury this material on site (if permitted by law). If left, dumped debris will encourage more dumping and will eventually have a negative effect on the roadway, its drainage system, the environment, and public perception. Beautify and/or barricade the dump site. Aesthetic barricades mixed with other adornments, such as wild flowers, etc., will discourage some illegal dumping.

---

### **Natural Material**

---

Often tree limbs, stumps, leaves, grass, rocks, and other natural materials from other locations are dumped along unpaved roads in ditches or other drainage paths. This too inhibits or redirects runoff which in turn erodes and/or weakens the roadway system.

Promptly haul away or properly bury wood and plant material on site (if permitted by law), or, use it in constructive maintenance practices along the roadway. Earth and stone materials can also be spread, buried on site, and/or used in constructive maintenance practices along the roadway. As with manmade materials, if left unchecked, dumped wood, plant materials, earth, and stone will encourage more dumping and will eventually have a negative effect on the roadway, environment, and public perception. Dry, woody materials along the roadside can be a fire hazard also.

---

## Roadside Vegetation Management

---

Proper maintenance of roadside vegetation will enhance and protect the roadway system, improve traffic safety, and improve public perceptions and attitudes. Thinning tree canopies over and alongside unpaved roads and removal of select trees will hasten drying and encourage grasses and smaller plants. Be careful not to remove mature trees unless absolutely necessary. Also, be careful not to grade or excavate too close to trees. A safe distance is outside the canopy drip line. Inside this distance can damage or kill the tree. Be careful not to cut or expose tree roots if possible. Cutting or exposing tree roots may cause a hazard by making the tree more easily uprooted. When roots are exposed, cover them as quickly as possible or cut them cleanly below the soil surface to prevent disease or other damage. Tree limbs broken during maintenance should be pruned close to the main trunk or branch.

---

## Retaining Walls and Headwalls

---

These structures provide good protection from erosive forces and lend a neat appearance to other structures such as culverts, bridges, and steep slopes. Inspect and protect walls when performing road and ditch maintenance. Place and compact soil in and around scoured areas of walls and use excavated materials to bolster the strength and stability of walls when performing maintenance. Consider installing stone or concrete headwalls where culverts or bridges are experiencing scour due to turbulence or high velocities.

## **Beavers**

Impoundments constructed by these animals are a great resource for filtering sediments and other pollutants from surface waters, but are a potential threat to roadways and their drainage systems. Dams constructed immediately upstream of a roadway may pose a flooding threat in heavy storms which may break the dam sending excess water onto the roadway. Dams constructed below the structure may inhibit runoff from properly flowing away from the roadway, causing runoff to back onto the roadway. This can cause weakening of the roadway, plugging of culverts with debris, and inappropriate diversion of runoff. Frequent maintenance checks in beaver prone areas can prevent severe damage by taking timely, corrective measures. Anti-beaver devices may be used to discourage beavers from plugging culverts or make them leave the immediate area.

## *Chapter 6*

# **SEDIMENT AND EROSION CONTROL TOOLS**

### **Description**

Sediment and erosion control tools are structures or measures, located in runoff drainage channels or near culvert outlets, which prevent or reduce sedimentation and erosion of earth materials caused by direct rainfall, runoff, wind, freezing, gravity, or a combination of these. These tools may be mechanical(structural), vegetative, or a combination. Some measures are simply armor to resist erosive forces while others reduce erosive forces. These reducers of erosive forces include structures or measures to control runoff velocity, reduce the flow grade, or dissipate energy. Structures involve the use of pipe, rock rip rap, rock gabions, wood materials, concrete, prefabricated blocks, geotextiles, earth, vegetation, and many other innovative resources, ideas, and processes.

### **Importance to Maintenance & Water Quality**

Today, many natural streams and channels have aggraded from the influx of silts and sediments from farming operations and erosion along unpaved roadways. This aggradation has filled many flood plains and wetlands which has diminished nature's method of purifying water, led to increased flooding in low areas, and reduced or endangered fish and plant resources.

Sediment and erosion control structures protect the integrity of runoff drainage systems, roadways, and embankments by reducing degradation and aggradation which can lead to roadway or bank failure, flooding, and/or recurring maintenance. Also, these structures and measures increase infiltration, reduce sedimentary pollutants which damage stream, lake, and pond ecosystems, and, reduce transport of debris which may accumulate and block channels and culverts.

Reducing runoff velocities and dissipating the energy contained within flowing water helps reduce and prevent the degradation of natural channels as well as man-made channels. Runoff volumes are reduced by the creation of better opportunities for infiltration. This becomes a two-fold benefit by decreasing the potential of erosion from overland flow while increasing groundwater recharge from increased infiltration. Streams, channels, and ditches have better opportunities to recover from scour and sedimentation by re-establishing or revitalizing vegetation growing within them and thus improving the ability of natural processes to filter and deliver runoff to creeks and rivers with less sediment accompanying it.

## Implementation

### Structures

#### Hay Bale Dikes

Very temporary structures constructed of rectangular hay bales tightly butted together, embedded four inches into the ground, and staked to the ground as shown in figure 6-1. Designed to temporarily impound or divert water, *not filter it*. Heavier, coarse sediments are settled out by the impoundment of water. The bales are too dense and not tall enough to act appreciably as filters. Use and installation technique is critical to proper performance.

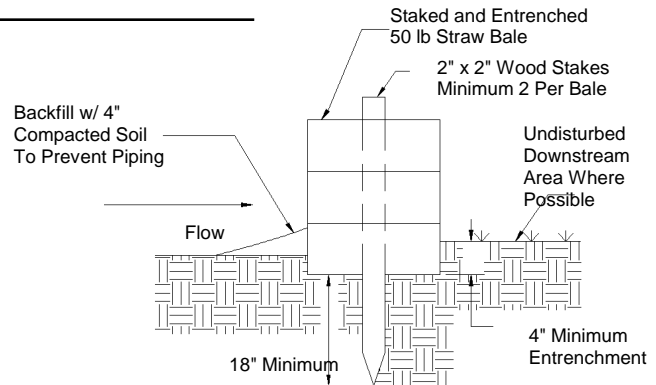

#### Criterion For Use :

Hay bale dikes should be used **only** in areas of low flow velocity, such as; where concentrated flows are very low and enough upgrade storage capacity is available so that runoff is not likely to overflow the top of the hay bales, and, on areas of sheet flow, such as slopes and graded areas, where a series of these dikes may be placed cross-slope on the contour with ends turned up to prevent flow around them.

Hay bale dikes usually require closer spacing as land/channel gradients increase. This is necessary to create more storage and induce more infiltration, and thus prevent or reduce the potential of flow over-topping the bales.

*Erosion on the backside of the hay bale structures, created from over-topping energy, may negate erosion control benefits created with the front-side settling of sediments.*

Use during seasons of low intensity storms and in areas where protection from sediment and erosive water flow is needed for durations of less than 60 days, such as;

Figure 6-1. Hay Bale Dikes

- a. Small construction sites/locations where individual structures are being constructed such as, drop inlets, permanent grade stabilization structures, pipes, culverts, grade work, etc. Hay bales are typically removed when these works are completed or shortly thereafter.
- b. Seeded or sodded areas. In some cases, where aesthetics is not a concern, hay bales may be left in place after vegetation is established.

Whenever possible, remove sediment buildup from the front (upstream) side after every sediment depositing event. Do not allow sediment to accumulate closer than six (6) inches of the top of the lowest hay bale. Re-secure and tighten all hay bale dikes after every rainfall event and replace damaged bales.



Ineffective Placement  
(Parallel to Flow)



Poorly Installed Hay Bales



Improper Construction, Ineffective  
Installation, and Mis-application  
(Concentrated Flow)



Exhibit 6.1a - Improper use and/or installation of hay bale dikes.



Exhibit 6.1b - Proper use and/or installation of hay bale dikes.

**Exhibit 6.1 - Hay Bale Dikes**



Exhibit 6.2a - Properly placed and erected silt fence.



Exhibit 6.2b - Improperly placed and erected silt fence.

**Exhibit 6.2 - Silt Fence**

## Silt Fence

Temporary structure constructed of pervious geotextile fabric supported vertically by steel or wood posts. Designed to slow, temporarily impound, and filter sediment laden water. Sediments are settled out by the impoundment of water and filtered by the fabric, although filtration diminishes with sedimentation sealing the fabric pores. May be used to redirect runoff instead of impounding it. Installation technique and maintenance is critical to proper performance.

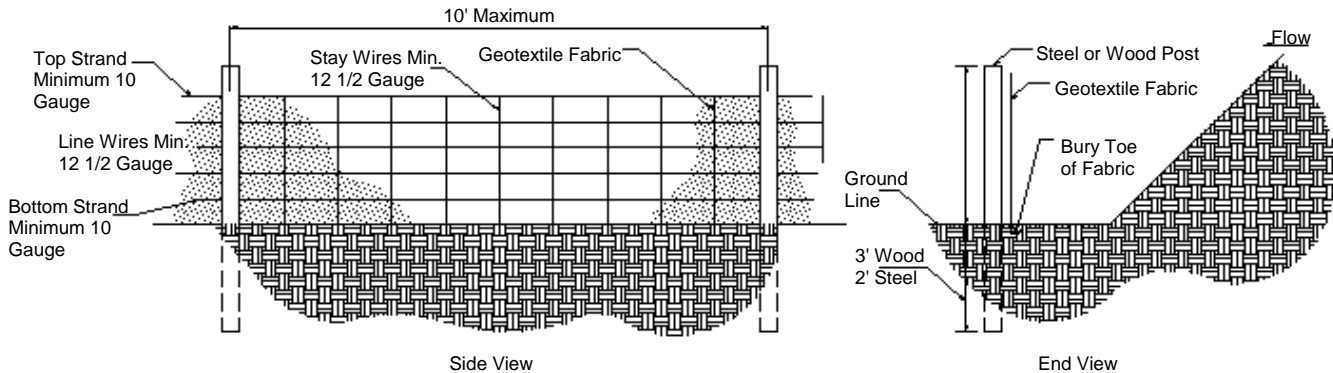

Figure 6-2. Silt Fence Details

### Criterion For Use :

To be used only in areas of low flow velocity where concentrated flow volumes are low, and enough upgrade storage capacity is available where runoff will pond, then filter through the fabric or infiltrate, and not overflow the top of the fence. Common use areas include slope toes and outlets where sheet flow from slopes and graded areas can potentially carry sediment off site.

Silt fence filters usually require closer spacing as land/channel gradients increase. This is necessary to create more storage and induce more infiltration, and thus prevent or reduce the potential of flow over-topping the fence.

Use in areas where protection from sediment and erosive water flow is needed for an indefinite period of time, such as;

- a. Large or small sites/locations where individual structural units are being constructed such as, drop inlets,

permanent grade stabilization structures, pipes, culverts, grade work, etc.

- b. At the perimeter of disturbed areas where runoff leaves the site.
- c. Seeded or sodded areas. In some cases, where aesthetics is not a concern and the structure poses no adverse conditions, silt fences may be left in place after vegetation is established.

Whenever possible, remove sediment buildup from the front (upstream) side after every significant sediment depositing event. Do not allow sediment to accumulate closer than half way of the top of the lowest point in the fence. Re-secure and tighten fencing and fabric after every significant runoff event, especially checking the toe of the fabric for breaches.

---

## Rock Ditch Check/Check Dam

---

Semi-permanent to “permanent” structure composed of stone, as shown in figure 6-3, which will eddy water behind it, settle out sediment, and allow water to pass through and/or over its crest. Once sediment has filled in behind the structure the active function of collecting sediment will cease, however, it will continue to act as a stabilizing force for the ditch bottom grade.

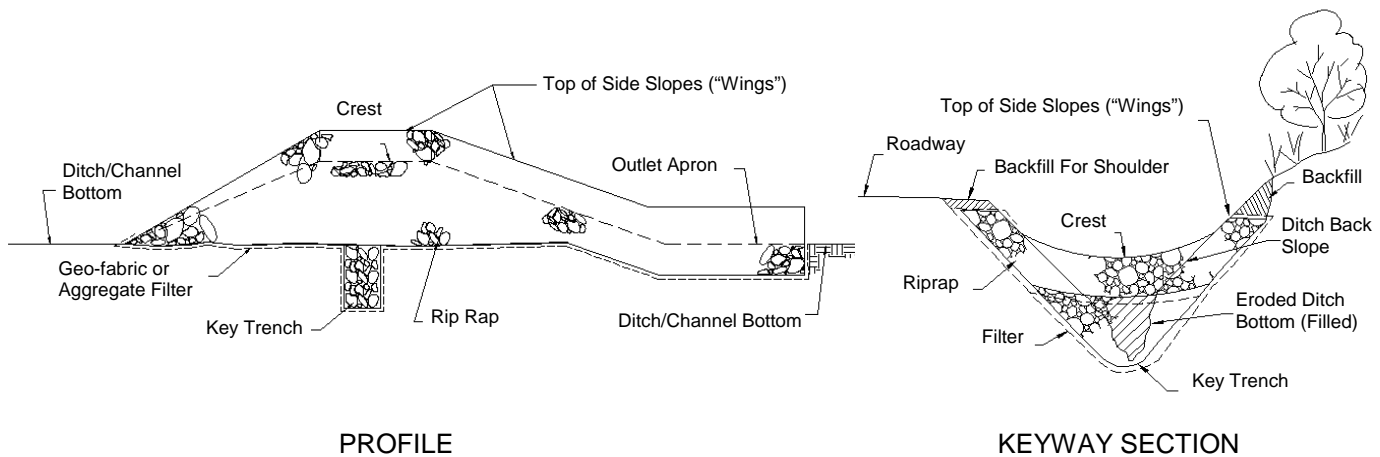

Figure 6-3. Rock Ditch Check/Check Dam Details

The roadway crown, shoulder, and ditch bottom elevations must be maintained constant for as long as possible to extend the life of these structures and make them cost effective. Unchecked roadway degradation renders these stationary structures useless and may allow them to become accelerants to erosion rather than aids against it.

For optimum performance, these structures must be designed by a professional engineer, meticulously installed, and rigorously maintained. Structures must be embedded into the side banks, toed into the channel bottom at the outlet, and have a flow channel deep enough to handle normal runoff to minimize the potential for over-flow scour around the edges. Also, there should be enough outlet apron to dissipate the energy of water overflowing the crest to protect the toe from the undermining scour which leads to failure. A toe-wall at the end of the apron is often necessary. Continual maintenance is critical until the structure has stabilized and “seated” itself.

Lateral runoff from adjacent roadway surfaces or back slopes must be directed safely into the ditch or structure to prevent washout along the edges of the structure. Construct the structure of stone large enough, or otherwise secured in place (ie. grouted, gabion, etc.), to resist expected velocities. A geotextile fabric or aggregate filter should lay between all stone to ground contact surfaces, with overlap at fabric seams, and fabric or aggregate overlapping the exposed edges at the surface as shown in figure 6-3.



---

## Level Spreader

---

Semi-permanent to permanent trench used to spread, and discharge water flow over a wide area. This structure reduces concentrated flow, increases infiltration, and allows for sediment to be removed by settling and filtering. Level spreaders are generally used at the toe of a slope, but can be used to intercept concentrated runoff and disperse it across the head (top) of a slope or grade. This application can be useful in protecting road banks from concentrated flow entering from upland drainage areas.

As shown in figure 6-4, it is constructed as a water impounding channel or trench, cut on a level contour into a slope or grade. The front (downslope) edge allows shallow discharge over its entire length when the impoundment is full. The impoundment should be shallow, but deep and wide enough to reduce surface turbulence from the runoff inflow allowing the water to evenly fill the impoundment and then flow smoothly over the discharge point along the front edge no deeper than 1/2" at peak design flow. The impoundment will catch sediment and will require periodic clean-out maintenance.

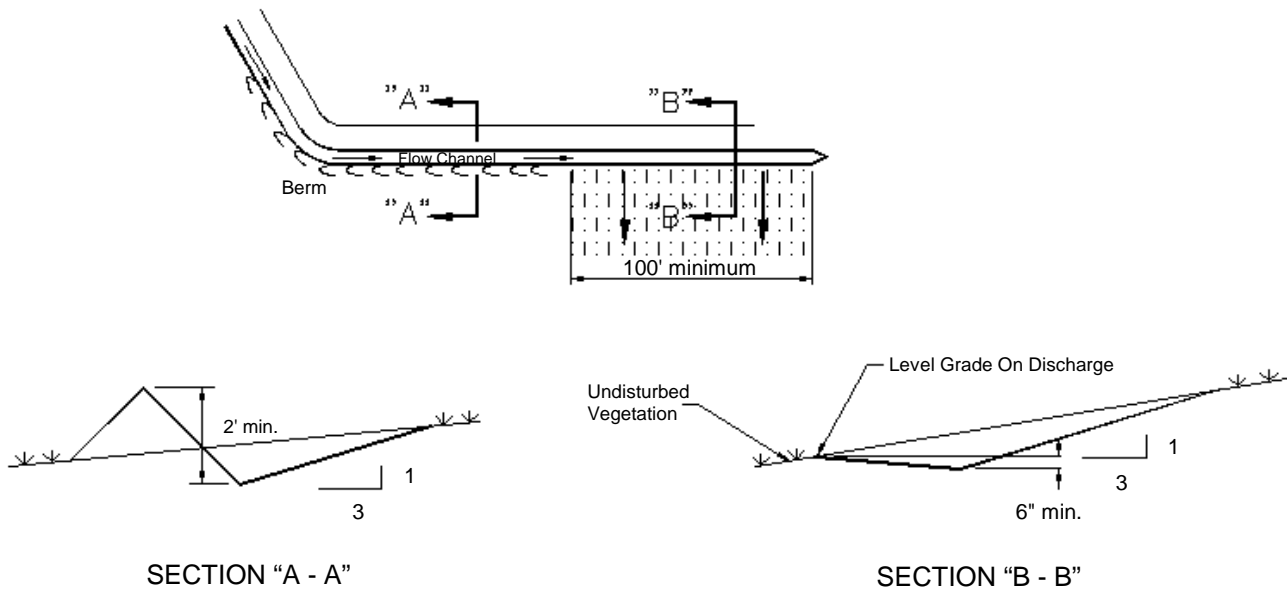

Figure 6-4. Level Spreader Details

---

## Log and Brush Check Dam

---

Semi-permanent or temporary structure constructed of brush intermeshed with logs staked to the ground or arranged across the channel as shown in figure 6-5 below. Geotextile fabric may be placed across the front face of the structure for added performance. These structures are designed to slow, temporarily impound, and filter sediment laden runoff. Sediments are settled out by the impoundment of water, and filtered by the brush and fabric. Installation technique is critical to proper performance.

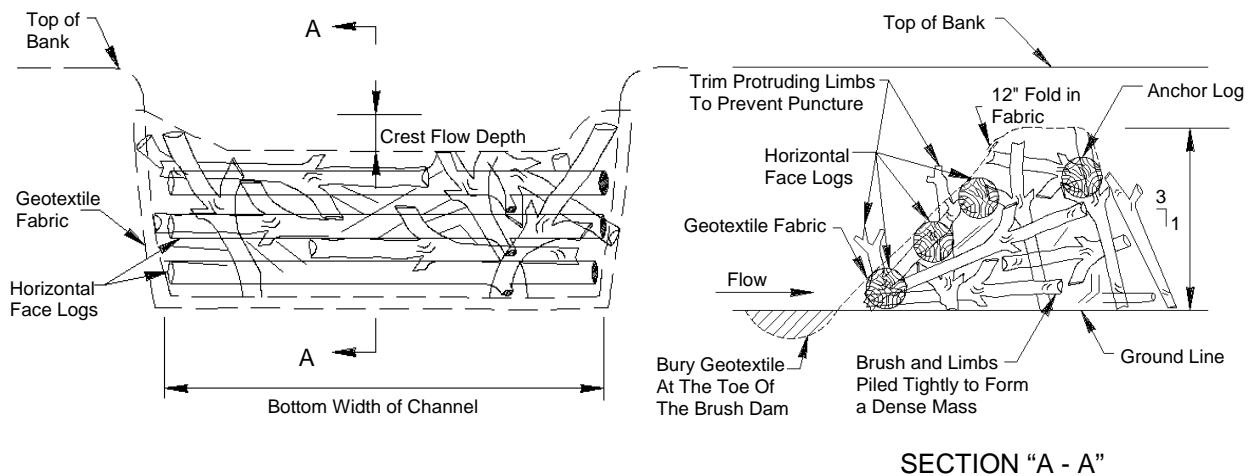

*Figure 6-5. Log and Brush Check Dam Details*

These structures are intended to be used in areas of high flow velocity and moderate concentrated flows. The structure should be designed for a given storage capacity where the design runoff will pond, then filter through the structure. Excess storm flow will overflow the top of the structure or will bypass, as per design, onto a stable outlet.

These structures are not likely to be used within road right-of-ways, however, there are feasible applications in specific situations where easements, public lands, or other permissible locations exist. Specifically, these structures will be used in areas where sediment detention is needed for an extended period of time, such as; road turn-outs, swales, ditches, intermittent streams, or other areas receiving concentrated flow from disturbed or fallow (bare) areas. Structures should be placed as near as possible to the perimeter of the disturbed areas where runoff leaves the site.

Other locations are low flow perennial streams below road crossings or other places where land disturbance due to construction and/or maintenance is taking place. These structures will almost always require removal after stabilization of disturbed area, however, they may be left in place if determined by the engineer that no adverse effects to the stream and surrounding hydrology

will occur. Sediment from the disturbed area, accumulated by the structure, should be removed and properly disposed as needed until re-stabilization is complete. Remove sediment buildup from the front (upstream) side before it accumulates within half way of the top of the lowest point in the structure.

---

### Sediment Trap

---

Temporary basin created by either excavation, earth or rock embankment, or a combination of these to intercept, trap, and retain sediment from runoff while allowing detained runoff to slowly drain, infiltrate, or both. Sediment laden runoff can be drained and filtered by perforated pipe, rock filtration and/or rock dam seepage, infiltration, or a combination of these. These structures are usually used during construction or maintenance practices. They are easily and economically constructed and offer versatility of location. Materials used to construct them can be demolished and constructively used or disposed on site when the structure's service area has been adequately stabilized.

Because of the predominantly temporary nature of these structures, they usually require removal of collected sediment after each runoff event to restore adequate operating capacity and are constructed with an emergency bypass for excessive runoff events. Larger sediment traps with extended sediment retention capabilities and large drainage areas should be designed by a professional engineer experienced in hydrology. "Rule of Thumb" criteria, developed by a professional engineer, may be used for local (countywide) application for limited size watersheds.

---

### Sediment Basin

---

Semi-permanent to permanent version of the Sediment Trap constructed by either excavation, embankment, or a combination of these to intercept, trap, and retain sediment from runoff while allowing detained runoff to slowly drain, infiltrate, or both. These structures, illustrated in figure 6-6, are used for indefinite periods of sediment collection associated with long term disturbance of the earth such as mining, farming, unpaved road drainage, etc. Sediment and runoff storage capacities are often larger than sediment traps, and embankments are usually constructed of more permanent materials such as compacted earth, rock, concrete, etc. Sediment laden runoff can be drained and filtered by perforated pipe, rock filtration, rock dam seepage, infiltration, pumping, or a combination of these. Three "clean water" drainage or discharge methods are described below.

*Riser pipe and barrel* - The top section of risers are most often perforated, but may not be, depending on storage volume of the basin, percolation/recovery rate, probable peak runoff volumes, other basin drainage mechanisms, or any combination of these.

*Riprap/aggregate filter dam* - This porous dam is constructed at least one foot higher than height at maximum design runoff retention volume. Runoff will drain through riprap and/or coarse aggregate leaving behind sediment. Rock in the dam may need cleaning and re-mixing to improve permeability when in use for extended periods or when frequent, sediment laden discharges have entered the structure. By-pass is usually the top of the dam.

*Underdrain filter* - An aggregate-shrouded pipe network buried at the bottom of the basin. This system is for a more elaborate, structure and works best where the basin is constructed in sandy soils. May be used in conjunction with other discharge methods.

A professional engineer experienced in hydrology should be consulted for design of these structures. Ideally, sediment basins should be elongated in the direction of flow with the length at least twice the width to obtain the most effective settling of sediments. Depth should be determined based on length and width dimensions and volume requirements for runoff storage plus sediment retention. Consideration may be given to outflow and/or infiltration versus inflow in determining runoff detention volume.

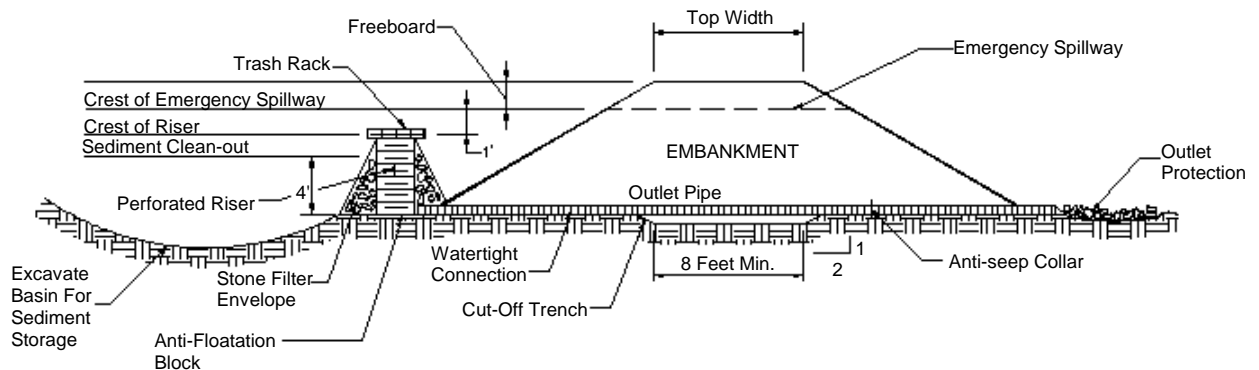

Figure 6-6. Sediment Basin Illustration

---

## Riparian Buffer

---

Area or strip of undisturbed vegetation between sensitive areas such as streams, wetlands, ponds, etc. and areas of land disturbance and/or fallow (bare) ground such as unpaved roads, construction sites, etc. as illustrated in figure 6-7. Ideally the vegetation consists of trees, shrubs, brush, grass, various under story vegetation, and bio-mass (dying and decaying plant materials). Riparian buffers can be naturally existing or may be designed and planted.



Left Side Basin



Right Side Basin

Typical Sediment Basin Use on an Unpaved Roadway



Other Types of Sediment Basins

**Exhibit 6.3 - Sediment Basins**

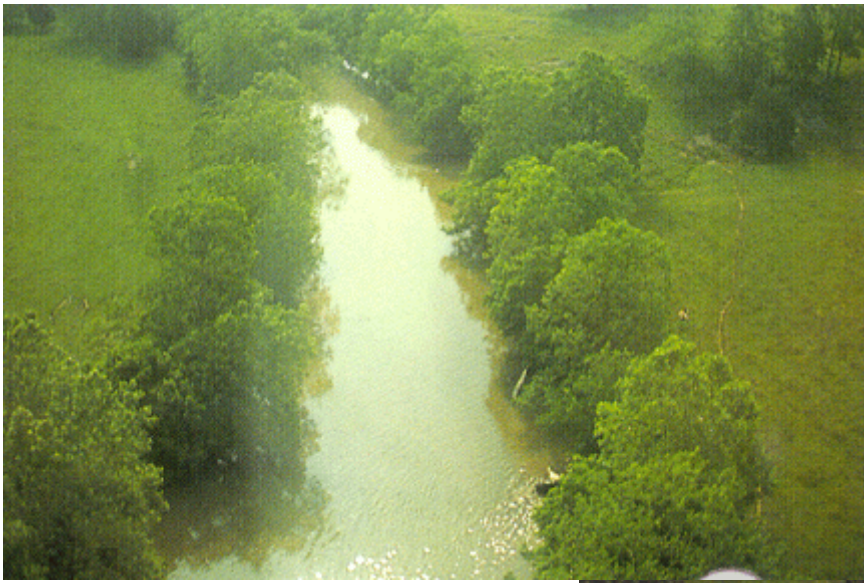

Established Riparian Buffers



Planted Riparian Buffers

**Exhibit 6.4 - Riparian Buffers**

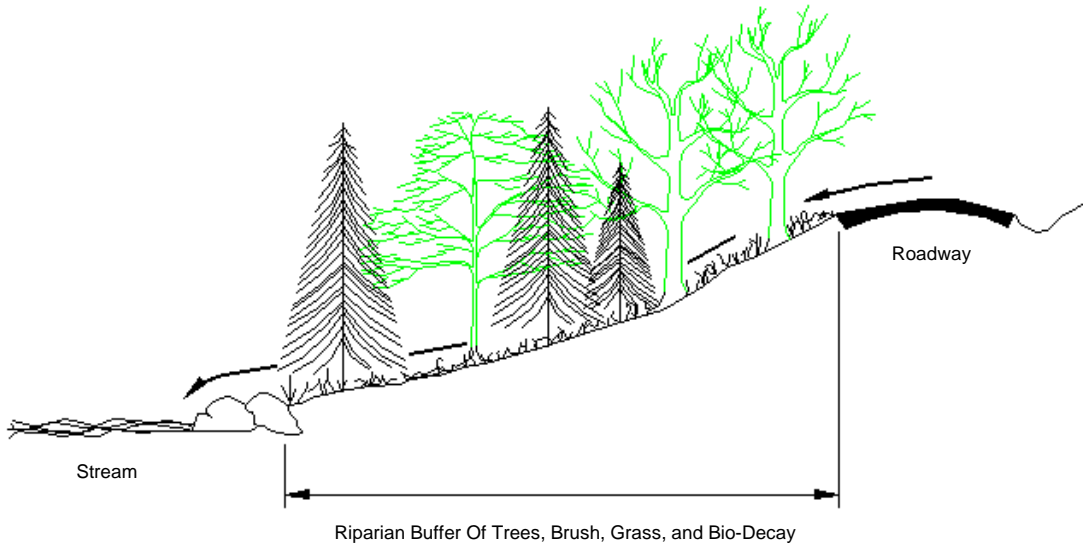

*Figure 6-7. Riparian Buffer Illustration*

Road ditches, turn-outs, and other water disposal systems from roadways should empty into a riparian buffer, whenever possible, before entering sensitive areas. The discharge from these disposal systems should be fanned (spread out) as much as possible as it transitions from the concentrated channel to the riparian buffer (see Figure 6-4, Level Spreader Details). The distance from concentrated discharge to sensitive areas should be adequate to allow vegetation to grow through and stabilize deposited sediments. The minimum distance should be fifty feet.

Riparian buffers may become filled and damaged from excessive sedimentation. This may require additional spreading of the runoff or delicate removal of sediment from the buffer. In either case, a need for additional upland sediment control is indicated.





## *Chapter 5*

# **BANK STABILIZATION**

---

### **Description**

Bank stabilization is the process of establishing and implementing resistive measures against erosion and failure of roadway cut slopes or fill embankments. Stabilization may be achieved by either mechanical(structural) means, vegetative, or both.

Erosion can be directly caused by direct rainfall, runoff, wind, freezing, gravity, or a combination of these. The magnitude of these parameters can be effected by changes in upland land use, fire, tree harvest, etc. Indirect causes include flow-line scour within a road ditch, diverted or impeded flow by obstacles within drainage ways and culverts, wave action, seepage, over-bank drainage, off-road vehicles, maintenance machinery, etc.

Bank or slope failure occurs when a section of the bank slides. There are many potential causes. One cause is too steep of a slope gradient for the strength of the soil. High shrink/swell soils (usually fine clays) tend to have the weakest slope stability. These soils crack during dry weather opening fissures which allow rainfall to enter, and thus saturate the soil causing high ranges of swelling. The swelling reduces the soil density, which never recovers when the soil dries out, thus causing further, more extensive cracking. Subsequent rainfall during this cycle will eventually deliver a load and lubrication which the weakened soil cannot resist, resulting in “slip-plane” failure. Other soils, including some sands and sand-clays, are just too weak to “stand” at the steep grades impose on them.

Other causes of slope failure have to do with improper soil compaction, slope toe erosion, groundwater pressure, and excessive artificial loads placed on the slope, such as building construction, automobile parking, etc.

### **Importance to Maintenance & Water Quality**

Proper long term stabilization of banks along roadways and drainage ways will significantly reduce if not prevent costly maintenance, and will contribute significantly to the reduction and prevention of considerable amounts of sediment delivery into streams and waterways. Stable road banks also decrease public disenchantment, improves motorist safety, improves traffic flow, and protects adjacent land.

## Implementation

---

### *Construction and Grading/Re-Grading*

---

Bank construction and maintenance procedures in relation to compaction (for fills), slope gradient, and surface grading is critical to establishing a long term, stable slope.

Fill slopes should be compacted to a density commonly stable for the soil material used. Loose fill should be placed on a relatively level, scarified surface (roughened one inch) in lifts not to exceed 12 inches, and thoroughly compacted before more material is added. Compaction equipment must cover the entire surface, preferably in a criss-cross pattern, sufficient enough times to achieve the desired compaction. Tests may be required to determine the level of compaction (density). With familiar soils, established, common, and proven methods may be routinely used for expediency and economy. Most fill slopes should be 3 feet horizontal to 1 foot vertical (3:1) or flatter for stability, however, some soils can be placed at steeper slopes to accommodate limited space. Evaluation of the soil material should be made by a professional engineer to determine whether slopes flatter or steeper than 3:1 should be used.

Smooth, and even grading of the slope surface will enhance aesthetics and will also improve the ability to establish a good vegetative cover and maintain it. Slope grades should be straight and true without humps, bellies, dips or ridges. This will reduce concentration of runoff on slopes and promote sheet flow which is less erosive and enhances infiltration of water needed for plant growth. Vertical tracking (up & down slope) with a dozer will also enhance infiltration.

---

### *Bank-Grading Techniques*

---

---

#### Terracing

---

The construction of benches on long and/or excessively steep slopes to provide breaks and near level “troughed” areas in the slope which will intercept runoff. These troughs are back-sloped from the slope face to catch runoff and channel it to either end of the embankment. (See figure 5-1).

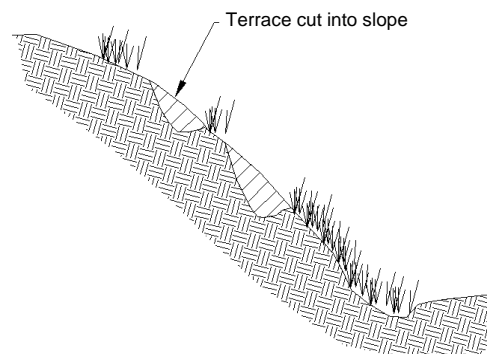

*Figure 5-1. Slope Terracing*

---

## Cutting and/or Filling

---

The removal and/or addition of soil to the bank to create the desired slope. May result in flattening the slope to a stable gradient, or involve replacing less stable soils with more stable soil material in the process of regrading the slope. Maximum slope grade should be 3:1 for fill slopes, and 2:1 for cut slopes. (See figure 5-2).

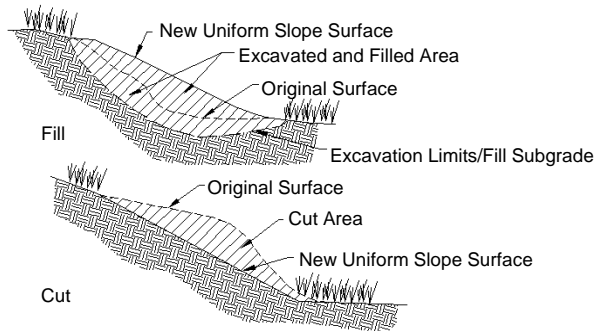

*Figure 5-2. Slope Shaping by Cutting and/or Filling*

---

## Keying

---

The cutting of a trench or bench into a slope surface prior to placing fill on it in order to prevent slippage or creep of the added fill. This method is often used when replacing slide material back onto the slope from which it came. (See figure 5-3).

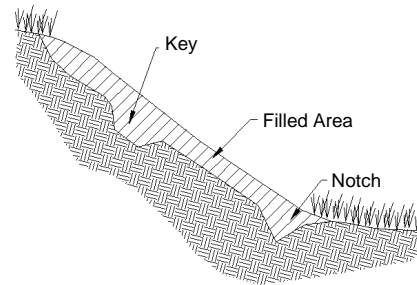

*Figure 5-3. Slope Keying for Fill Placement*

---

## Counter-weighting

---

The placing of material (soil, rock, etc.) at the toe of a slope to prevent or halt sliding. The mass weight of the counter-weighting material must exceed the mass weight of the sliding material above it. (See figure 5-4).

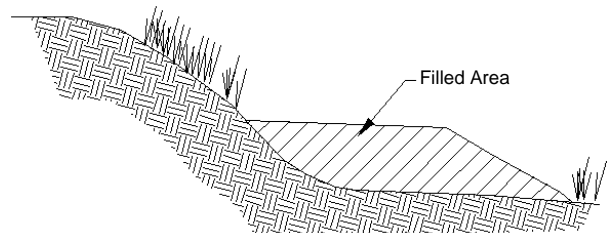

*Figure 5-4. Counter-weighting Toe of Slope*

---

## *Vegetation by Grass Seeding*

---

Grass seeding is the most efficient and cost effective method of stabilizing banks and slopes. This method should always be considered first and use wherever possible. Grass will slow water movement and allow more infiltration. It will effectively hold soil particles in place, reducing sedimentation. The following should be followed when establishing vegetation by seeding.

- a. Slopes to be seeded should be no steeper than 2 horizontal to 1 vertical (2:1) and should be covered with a minimum of 2 inches of topsoil. Finish grading should always follow top soil placement.
- b. Where soils are unstable, use sod or erosion control blanket and place immediately. Consider mulching graded and finished areas before a rain event if seeding can not be performed.
- c. Seed bare areas as soon as possible after disturbance, preferably as soon as a significant area is graded and finished and before the next rain event.
- d. Fertilize and lime the area as needed based on soil condition and disk or rake it into the soil surface to a depth of 2 to 4 inches.
- e. Use temporary seeding when outside the seeding dates for permanent vegetation.
- f. Apply a seed mixture which is appropriate for the climate, soil, and drainage conditions of the site.
- g. Seeding can be done by hand or machine broadcasting, or by hydro-seeding. **Do not mix seeds of different sizes** when broadcasting as this will yield an uneven disbursement of seeds. Hydro-seed areas where it is unlikely to get an even disbursement of seeds or a satisfactory germination.
- h. Mulch the surface immediately at a rate of 1-1/2 tons per acre and anchor with a disk harrow, mulch anchoring tool, or by tracking. Tracking the mulch in with a dozer is acceptable where soil conditions and moisture are ample to avoid sticking, and the mulch can be adequately creased into the earth. Tracking must be done walking the dozer up and down the slope, making the track creases as near perpendicular to the slope grade as possible.
- i. Seeding can sometimes be use in combination with other type vegetation such as trees, shrubs, willow spikes, etc. planted after seeding is complete.

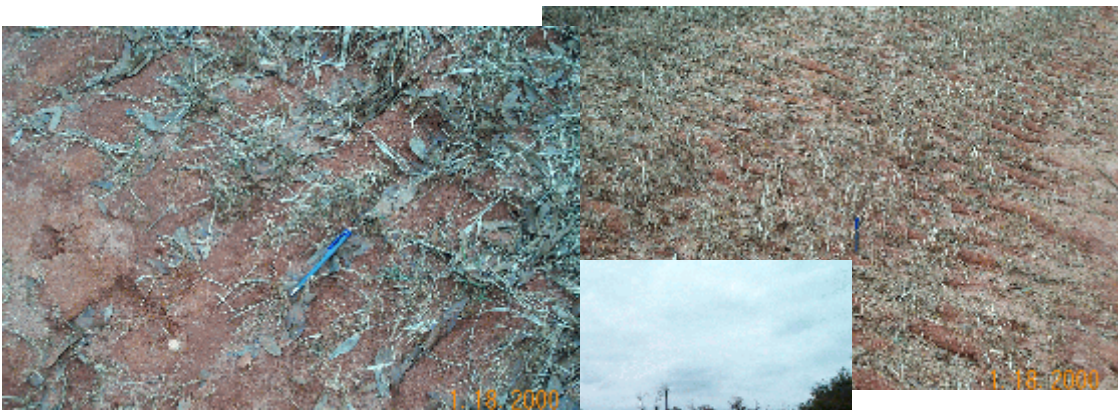

Proper seedbed prep, and straw or mattress mulching, including crimping or pinning. . .



. . . along with other pre-establishment site protection will yield well vegetated, stable, and more easily maintainable . . .



roadway shoulders . . .



roadway ditches . . .



soil storage areas, . . . culvert inlets & outlets, . . . and sediment control.



**Exhibit 5.1 - Vegetation by Grass Seeding**



Live Stake



Live Stake Planting



Two Year Growth



Live Fascine Installation



Live Fascine Fabrication



Bank Trenching for Fascine Installation



Second Growing Season



Brush Mattress Installation



Two Month Growth



Two Year Growth

**Exhibit 5.2 - Vegetation By Trees & Shrubs**

---

## Vegetation by Trees & Shrubs

---

Trees and shrubs can be used to create a good vegetative filter strip and stabilize steep or wet slopes, stream banks, and/or other areas where stronger and/or larger vegetation than grass is needed for stabilization. Deep rooted species of trees and shrubs provide greater protection against soil slippage problems.

Use native plants of the area to ensure adaptability and reduce costs. Identify plants in the area which are proven to provide the protection and stabilization desired. Some plants common to the CPYRWMA area which are often used for stabilization are willows, alders, and dogwoods. Use the most effective, appropriate technique in planting and establishing trees and shrubs for bank stabilization.

---

## Live stakes

---

Cuttings of live branches neatly pruned of limbs, usually 1/2 to 1-1/2 inches in diameter, and 2 to 3 feet long. This technique is inexpensive and can be used when time and/or resources are very limited and the site is not complicated. See figure 5-5 below.

1. The basal end should be cut at an angle to facilitate insertion into the ground.
2. Stakes are driven into the ground perpendicular to the slope, basal end first (buds oriented upward), until only 2" to 3" of the stake protrudes above the ground.
3. Stakes are planted in rows on the contour. Stakes in each successive row are staggered yielding an alternating grid pattern with two to four stakes per square yard.
4. Stakes should be cut during dormant seasons and installed the same day as cut, or temporarily stored (a few days) in a very moist, cool environment until use.

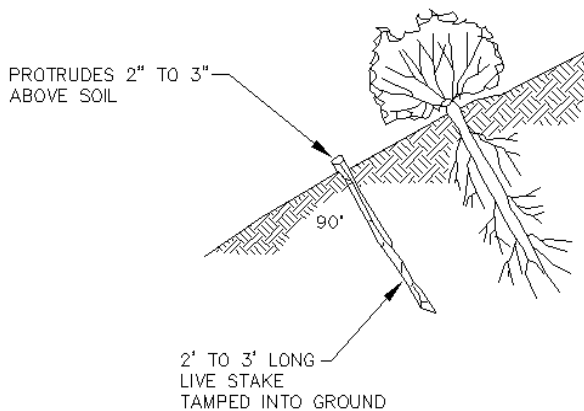

*Figure 5-5. Live Stake Planting*

---

## Live fascines/wattle/bundles

---

Long bundles, 5 to 30 feet in length and 6 to 8 inches in diameter, of live branches tied together with growing tips oriented the same direction and tops evenly distributed throughout the length of the bundle. See figure 5-6 below.

1. Can be used on slopes as steep as 1' horizontal to 1' vertical.
2. Bundles are placed in a 12 to 18 inch deep trench dug along the contour of the slope.
3. Bundles should be secured with live stakes placed 33° to 45° off horizontal, basal end down, and strong dead stakes placed vertically through the bundle. All stakes should be 2 to 3 feet long and protrude 2" to 3" above the soil.
4. Bundles are covered with a moist, compacted soil backfill.
5. Bundles should be cut during dormant seasons and installed the same day as cut, or temporarily stored (a few days) in a very moist, cool environment until use.
6. Installation of this practice begins at the toe of the slope and progresses up-slope.

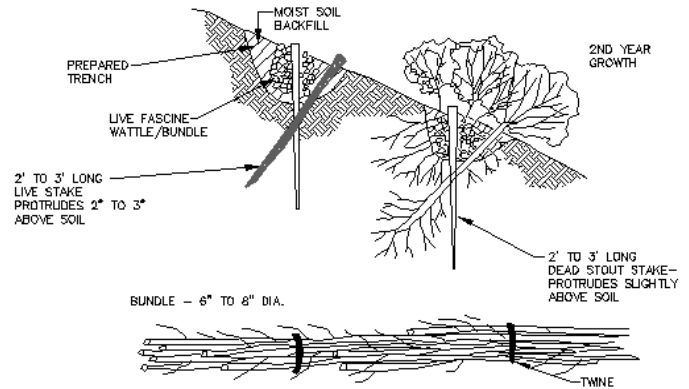
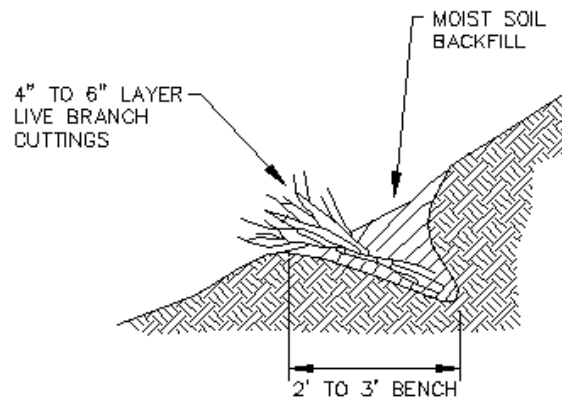

Figure 5-6. Live Fascines/Wattles/Bundles

## Brush Layering

Layer of live branches, 1/2 to 2 inches in diameter and 3 to 4 feet long, laid in a benched trench on the contour, and used to break long slopes into smaller slope lengths. See figure 5-7 below.

1. Branches are placed in a slightly inward sloping, benched trench, extending 2 to 3 feet (horizontal distance) into the slope face. Branches are placed with growing tips (buds) outward.
2. Branches are placed in the benches in a slight criss-cross or overlapping pattern.
3. Layers are covered with a moist, compacted soil backfill.
4. Branches should be cut during dormant seasons and installed the same day as cut, or temporarily stored (a few days) in a very moist, cool environment until use.
5. Installation of this practice begins at the toe of the slope and progresses up-slope.



DETAIL - BRUSH LAYERING

Figure 5-7. Brush Layering Details



---

## Sprigs/plugs

---

Individual plant stems with roots or rooted cuttings. Often used on filled slopes in conjunction with soil reinforcement materials. See figure 5-8 below.

1. Place sprig/plug in a hole dug at least twice the root ball diameter. Tamp fill soil firmly around root ball leaving no air pockets. Initial saturation around each plant will help ensure consolidation of soil around the root ball and help eliminate air pockets which will dry out the root ball.
2. Plant sprigs/plugs in rows on the contour with sprigs/plugs 1/2 to 1 yard apart. Sprigs/plugs in each successive row are staggered yielding an alternating grid planting pattern.

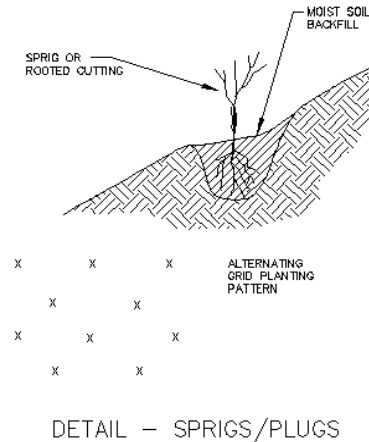

Figure 5-8. Sprig/Plug Planting

---

## Structures

---

In many cases, permanent or semi-permanent structures must be constructed to support, reinforce, or establish a stable condition or environment to protect road and ditch banks.

---

### Gabion Retaining Wall

---

Rectangular wire mesh boxes filled with stone, stacked and assembled as a near vertical or stepped wall (figure 5-9) to support the earth material behind it. This structure provides a slope face which can be used where there is limited or no room for a stable inclined earth slope. Gabions can also provide a non-erosive surface for road ditch back-slopes, and can increase infiltration by absorbing some runoff into its porous mass where it is held.

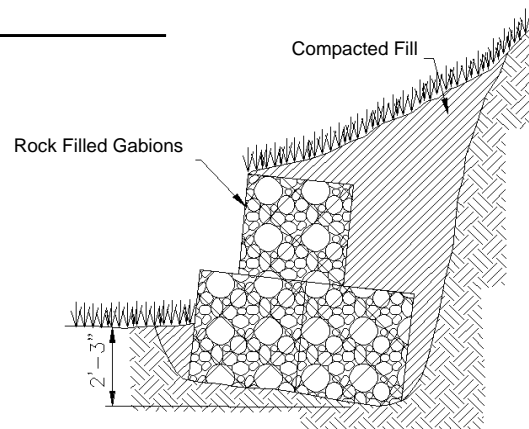

Figure 5-9. Gabion Retaining Wall

---

## Vegetated Gabion Retaining Wall

---

Rectangular wire mesh boxes filled with stone, stacked and assembled as a near vertical or stepped wall and combined with live branches (as used in brush layering, figure 5-7) to support the earth material behind it in a more permanent, aesthetically pleasing manner. Roots, stems, and associated plant growth will eventually intertwine itself with the stone in the gabions and take the place of the wire mesh when it has deteriorated away (figure 5-10).

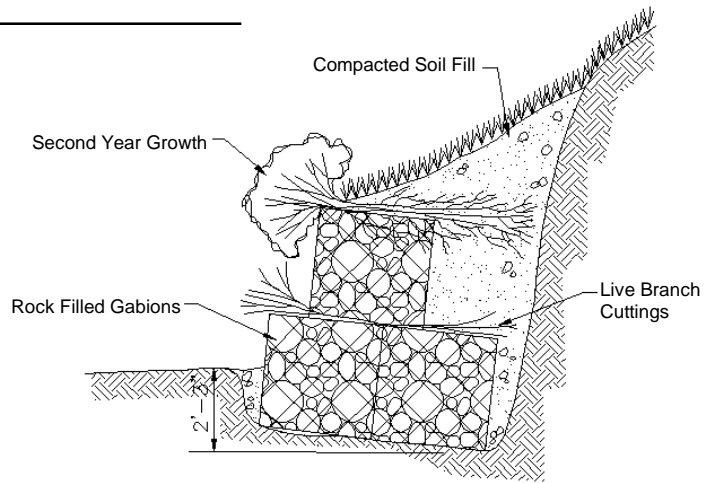

*Figure 5-10. Vegetated Gabion Retaining Wall*

---

## Log or Timber Crib Retaining Wall

---

Rectangular box made of alternately placed logs or treated timber in a log cabin style construction, filled with soil, rock, or other fill material to provide a stable and supported road or ditch bank. As shown in figure 5-11a, this structure provides a near vertical slope face which can be used where there is limited or no room for a stable inclined earth slope.

Also, as shown in figure 5-11b, the structure can be made more permanent, stable, and aesthetically pleasing by adding live branches (as used in brush layering, figure 5-7). Roots, stems, and associated plant growth will eventually intertwine itself with the wood structure and backfill, thus establishing natural stability. These Structure may be step-constructed to provide planting areas.

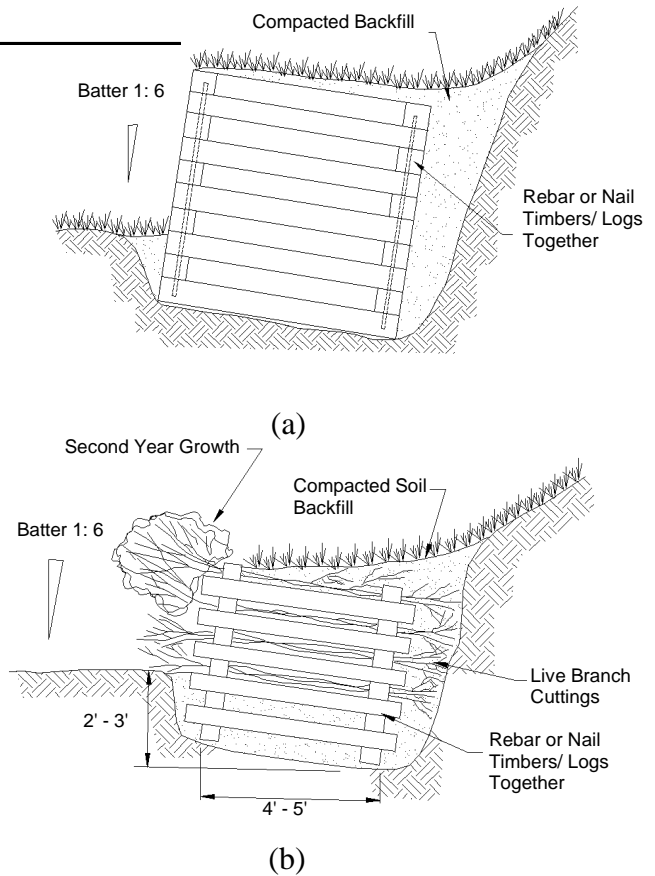

*Figure 5-11. Log or Timber Crib Retaining Wall*



Preparing Foundation of Structure. Rock Fill (Optional) Placed in the Foundation of Structure to the Level of Inundation. Soil Fill May be Used When Inundation or Perennial Flow Will Not be Encountered.

Brush and Wood Member Placement



Frontal View of Completed Live Cribwall



**Exhibit 5.3 - Live Crib Wall**



Vegetated Riprap Revetment by Design



Mechanical Riprap Basin Revetments  
Vegetated Naturally with Willows  
(Growth Age is a Beaver-Pruned Four Years)

Two Years Growth



Mechanical Riprap Basin Revetment

**Exhibit 5.4 - Vegetative and Mechanical Riprap Revetments**

As fill is placed in the crib, lay mats of branches in a criss-cross pattern on top of each fill layer which coincides with an opening between the timbers at the face of the structure. Branch cuttings must be long enough for the basal ends to reach the undisturbed soil at the back of the crib while the growing tips (buds) extend outward approximately 12 inches from the face of the wall.

Each layer of branches shall be covered by at least 2 inches of compacted soil. Fill shall be subsequently placed up to the next brush layer level.

---

### Mechanical Riprap Revetment

---

A lining of rock riprap covering the surface of a slope or embankment to protect it from erosive forces. Usually used when vegetation is not adequate to protect the slope such as on very steep slopes, sharp directional changes in stream flow, sharp turns in the stream or channel itself, where streams are constricted by bridges or culverts, etc.

Rock size is dependent upon the application. Larger stone will be required for stability where flow volumes and velocities against the riprap are high. Riprap layer thicknesses should be based on maximum rock diameter used and the application. A professional engineer should be consulted where stream flows will be encountered. Riprap armor against flow must always be underlain with a filter such as graded aggregate or geo-fabric.

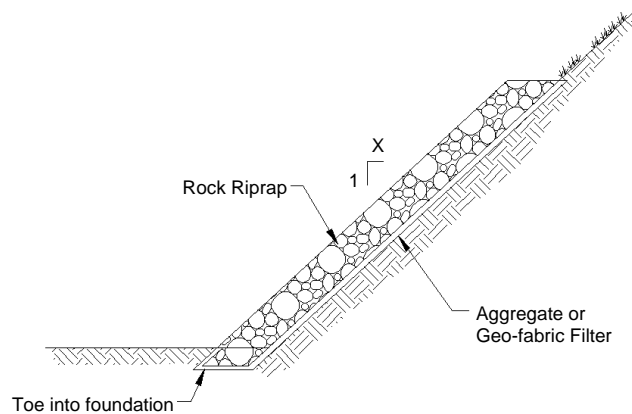

*Figure 5-12. Mechanical Riprap Revetment*

---

## Vegetated Riprap Revetment

---

A lining of rock riprap covering the surface of a slope or embankment with live stakes driven through the voids in the riprap and into the subgrade (figure 5-13) to provide enhanced stability and protection from erosive forces. This type of structure can be a near permanent solution to problems recurring when flows and velocities reach extremes, and can also be used in design to reduce the thicknesses and height required in mechanical riprap revetments.

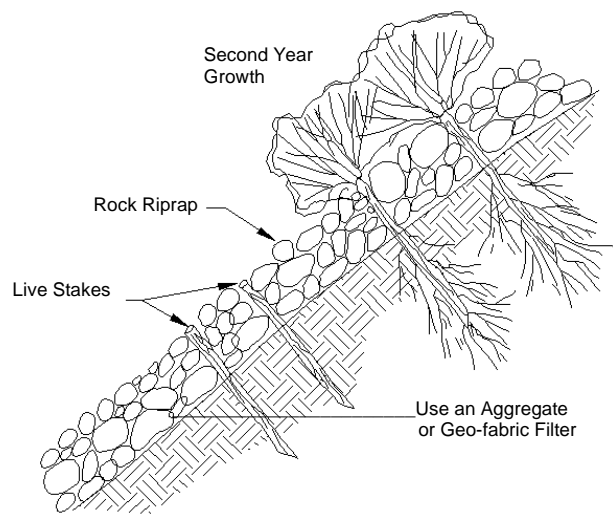

Figure 5-13. Vegetated Riprap Revetment

---

## Mats and Blankets

---

These products and materials are used to prevent erosion on a temporary basis on steep slopes, in ditches with high flow velocities, and other areas prone to erosive force. They usually deteriorate giving way to vegetation to hold the soil. Some of these products may be spaced longitudinally with the flow in channel flow situations, or laterally across the flow in sheet flow situations such as on slopes.

Examples are: *Jute Matting* - an undyed yarn, woven into an open mesh (usually 1 inch square openings). It is lain over seeded & mulched areas to hold in place and may be used to cover an entire area or spaced on the contour to break concentrated flow and check erosion; *Mulch Blanket (Temporary)* - mulch materials (straw, wood fibers, coconut, etc.) sandwiched between photo-degradable plastic. This product provides the mulching and is lain over seeded areas. It may be used to cover an entire area, but is mostly used in strips on the contour, in specific areas where mulch anchoring is difficult, or where a more intense strength mulching is necessary. *Mulch Blanket (Permanent/Semi-Permanent)* - mulch materials (straw, wood fibers, coconut, plastic coils, etc.) and non-woven geo-fabric sandwiched between photo-degradable plastic. This product is used for resisting surface slippage problems and to provide a stronger resistance to erosive forces. It is often buried and usually requires special engineering and design.

Below are installation recommendations for proper and effective use of these products.

- [] bury up-slope ends or edges in a check slot, backfill, and tamp securely in place.
- [] Unless otherwise recommended or specified by manufacturer, overlap ends 12 inches and pin securely. Up-slope section lies over down-slope section where applicable.
- [] Unless otherwise recommended or specified by manufacturer, overlap edges 4 inches and pin securely. Up-slope section lies over down-slope section where applicable.
- [] In accordance with manufacturers recommendations, securely anchor mats with backfilled check slots spaced along the length, and anchor each mat to the earth surface with stakes, pins, and/or staples.
- [] make sure all areas prone to up-lift, due to tension in the material, are thoroughly and securely pinned to the ground. Examples are: crease points where the slope changes abruptly (where a flat ditch bottom and its side slopes intersect), swales, or concave slopes.

---

## Geotextiles

---

Permeable synthetic materials manufactured for use in protecting and filtering soils and/or increasing the strength of the soil profile.

*Filter* - woven or non-woven fabric. Often used in lieu of an aggregate filter under riprap, gabions, and other structures requiring filtering to inhibit migration of finer soil and fill particles.

*Reinforcement Fabric* - webbed fabric which can be placed at or below the soil surface to provide improved strength and erosion resistance to the soil surface or profile. Usually requires specialized engineering and design. Often installed horizontally between soil layers of a slope or embankment to increase soil strength and protect against slides. Available in various shapes, sizes, strengths, and configurations.

*Reinforcement Grids* - pocketed, webbed material forming cells which can be placed at or below the soil surface, filled with soil or other fill material, to provide improved strength and erosion resistance to the soil surface or profile. Usually requires specialized engineering and design. Often installed at the surface. Cells are filled with soil and/or aggregate with a layer of topsoil added, then vegetated with seed or sod, or, filled with aggregate without vegetation to provide a non-erosive surface conducive to traffic or simply for reduced maintenance and/or aesthetics. Available in various shapes, sizes, strengths, and configurations.





## *Chapter 4*

# **OUTLET STRUCTURES**

---

### **Description**

Outlet structures are used to reduce and/or control energy from ditch or culvert discharge, and release the discharge downstream under controlled, stable conditions.

### **Importance to Maintenance & Water Quality**

Outlet structures reduce the velocity of water carried by road ditches and culverts, therefore helping to control sedimentation. Water should outlet to areas with moderate slopes and vegetative filter strips or riparian areas before entering surface waters. This type of outlet, often referred to as day-lighting, will allow for most of the sediments and other pollutants to be removed before runoff enters surface waters.

### **Location**

Outlet structures should be located where concentrated, turbulent, and/or high velocity flows are discharged onto areas which can be erosive, or where the discharged water requires filtration or settling of sediments. This can be outlets for swales and road ditches, flumes, runoff management culverts within the road ditch system, or culverts used at stream crossings.

### **Implementation**

---

#### *Structures*

---

---

#### *Splash/Stilling/Plunge Basin*

---

Basins (usually rock-lined) which are water-filled, or will fill with water during runoff events, located at high-energy outlets of conveyance structures such as steep flumes, and more usually, cantilevered pipe outlets.

The purpose is to use the pooled water to dissipate the energy of the flowing water discharged by the conveyance structure. Basins are usually constructed as a depression below the outlet channel elevation as shown in figure 4-1, but can be constructed with the basin bottom at the outlet channel elevation and the basin formed by constructing a weir (riprap, gabion, etc.) across the outlet channel as shown in figure 4-2. The basin is usually wider than the outlet channel by

design and tapers to fit the existing channel at the basin exit point. The basins must always be lined with a properly sized and/or classified, non-erosive lining such as riprap, concrete mats, gabions, etc. underlain with filter fabric or a graded aggregate filter. These structures require the design services of a professional engineer.

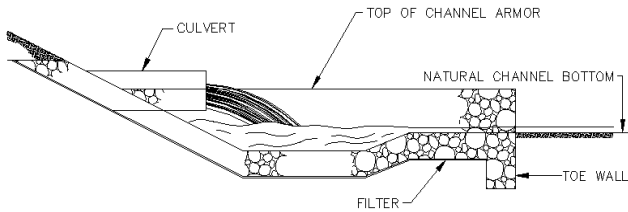

*Figure 4-1. Depressed Type Plunge Basin Illustration*

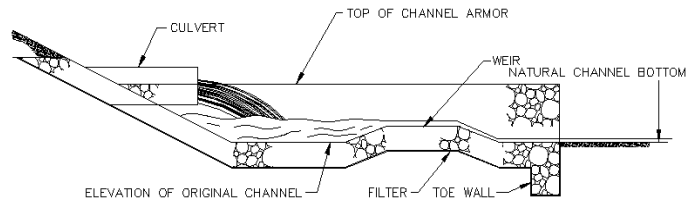

*Figure 4-2. Weir-formed Plunge Basin Illustration*

---

### Splash Apron

---

A widened, flat, armored area, level to slightly sloping, located at the low-energy discharge point of conveyance structures and/or splash/plunge basins. Flow exiting this structure should enter a stream or vegetated outlet.

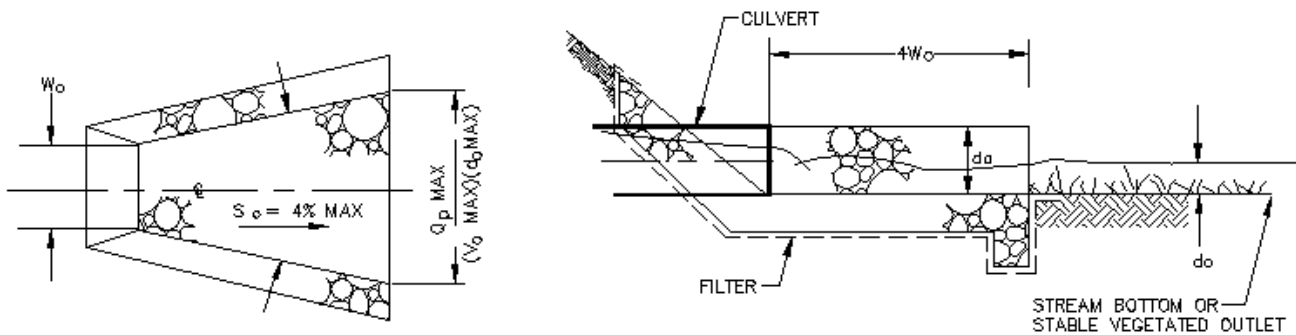

*Figure 4-3. Splash Apron Illustration*

As shown in figure 4-3, the structure's bottom dimensions taper from a narrow width at the conveyance structure discharge point to a wider dimension at the outlet some distance downstream. This spreads the water in a fanning action over the rough, armored surface reducing the velocity, and promoting sheet flow as the water exits into streams or onto vegetated



Exhibit 4.1a - Depressed-type energy dissipating basin at culvert discharge with transition apron to outlet channel.



Exhibit 4.1b - Depressed-type plunge basin at culvert discharge with transition apron to outlet channel.



Exhibit 4.1c - Weir-formed plunge basin at culvert discharge with transition apron to narrow outlet channel.

**Exhibit 4.1 - Splash/Stilling/Plunge Basins**



**Exhibit 4.2 - Drop Inlet/Box/Manhole**



**Exhibit 4.3 - Stilling Well**

areas. Armored side slopes are often necessary to prevent scour and erosion along the edge of the structure. The armor usually extends above and around pipe structures and blends into other conveyance structures to prevent scour and undermining at the discharge point. Toe walls may also be necessary where the structure outlets onto earthen surfaces. Armor material should be sized and/or classified to withstand the maximum design discharge velocities.

---

### Drop Inlet/Box/Manhole

---

An enclosed structure, constructed or prefabricated from reinforced concrete, concrete blocks, bricks, plastic, or other sound structural material, which will receive the discharge end of a culvert, flume, ditch, etc., dissipate the energy, and safely release the discharged runoff at a lower elevation. See figure 4-4 below.

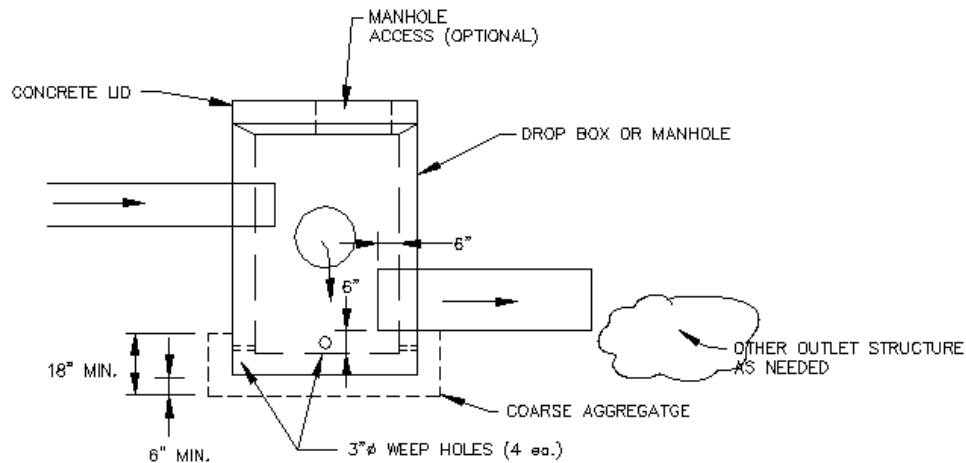

*Figure 4-4. Drop Inlet/Box/Manhole Illustration*

This structure works well where there is a severe cross-slope from one side of the road to the other and a cross-drain culvert is installed, or where there is a desire to reduce road ditch and flume slopes. This situation is often found where head cutting gullies have eroded up to the roadway. These structures require the design of a professional engineer.

---

### Stilling Well

---

An enclosed structure, constructed or prefabricated from reinforced concrete, concrete blocks, bricks, plastic, or other sound structural material, which will receive the discharge end of a culvert or pipe, dissipate the energy, and safely release the discharged runoff at a higher level.

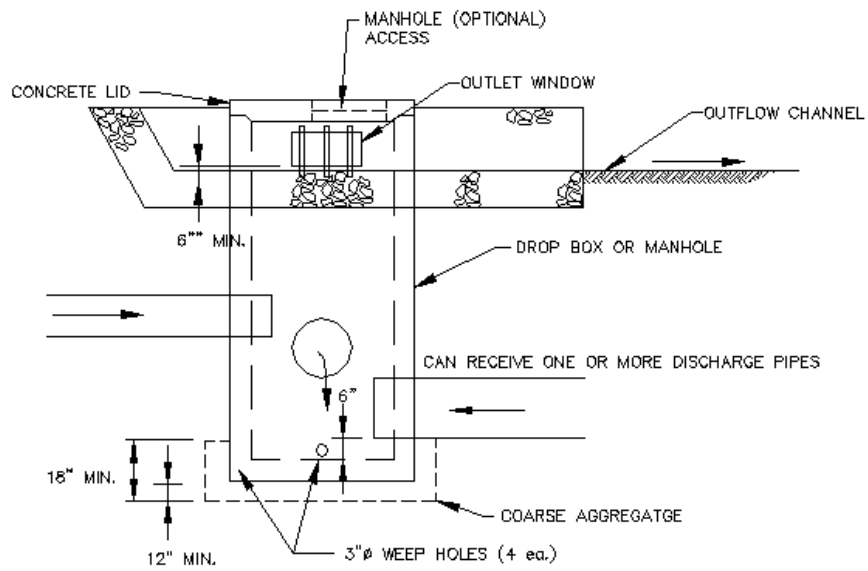

*Figure 4-5. Stilling Well Illustration*

- a. To be used only at the singular outlet location of one or more pipes.
- b. Use only when lowest pipe *inlet* invert will be higher than the outlet invert of the stilling well structure.
- c. This structure works well in areas where energy dissipating structures are needed at the ends of pipes and there is limited space to install such structures. Also can be a cost-saving structure.
- d. These structures require the design of a professional engineer.

## *Chapter 3*

# CULVERTS

---

### **Description**

A culvert is a closed conduit used to convey water from one area to another, usually from one side of a road to the other side.

### **Importance to Maintenance & Water Quality**

Disposal of runoff from roadway ditches will help preserve the road bed, ditches, and banks. Strategically placed culverts, along with road ditch turn-outs, will help maintain a stable velocity and the proper flow capacity for the road ditches by timely outleting water from them. This will help alleviate roadway flooding, reduce erosion, and thus reduce maintenance problems. In addition, strategically placed culverts help distribute roadway runoff over a larger riparian filtering area. Culverts preserve the road base by draining water from ditches along the road, keeping the sub-base dry.

### **Culvert Profile**

---

#### *General*

---

Culverts can be divided into two functional types: *Stream Crossing* and *Runoff Management*. The first culvert type, *stream crossing culvert*, is self defining. A culvert is required where the roadway crosses a stream channel to allow water to pass downstream. The second type culvert, *runoff management culvert*, is one which is strategically placed to manage and route roadway runoff along, under, and away from the roadway. Many times these culverts are used to transport upland runoff, accumulated in road ditches on the upland side of the roadway, to the lower side for disposal. These culverts are commonly called *cross-drains*.

Installation, modification, and improvements of culverts should be done when stream flows and expectancy of rain are low. Ideally, the entire installation process, from beginning to end, should be completed before the next rain event. All existing and/or reasonable potential stream flows should be diverted while the culvert is being installed. This will help reduce or avoid sedimentation below the installation site.

### ■ *Culverts For Stream Crossings*

When installing culverts (and bridges) for stream crossings, seek to maintain the original and natural full bank capacity (cross-sectional area) of the channel. Constrictions at these points are contributing factors in costly bridge and culvert “blow-outs” which generate a large volume of sediment deposited directly into the stream. Align and center the culvert with the existing stream channel whenever possible. As a minimum, align the culvert with the center of the channel immediately downstream of the outlet. If channel excavation is required to help align the culvert, it is frequently best to excavate the upstream channel to fit the culvert entrance and align the outlet with the existing natural channel. Minimal disturbance of the channel at the culvert outlet should be the priority consideration. Inasmuch as possible, the grade of culverts should be determined by the grade of the existing channel, but usually not less than 0.5% nor more than 1%. The outlet should discharge at the existing channel bottom. A professional engineer, experienced in hydrology and culvert hydraulics, should be consulted for determination of actual culvert grades when dealing with peculiar alignment or laying conditions, and upon any deviation from normal and usual installation procedures. Keep disturbance of the channel bottom, sides, adjacent land, and surrounding natural landscape to a minimum during installation. Install energy dissipating structures and/or armor at the outlet where scour and erosion are likely to occur from high exit velocity due to steep culvert installation, near proximity to channel banks, drops at the end of the culvert, etc. (See Chapter 4 on OUTLET STRUCTURES). Establish and maintain at least one foot of road bed cover over all culverts. Two feet or more cover is the desired optimum.

### ■ *Culverts For Runoff Management*

Where cross-drains are needed in conjunction with “turn-outs”, it is ideal to place culverts no more than 500 feet apart along the roadway to control the volume and velocity of flow within road ditches. Steeper road slopes may require closer spacing to discharge accumulated runoff in excess of ditch capacity and/or to keep velocities down. Inasmuch as possible in non-stream crossing locations, a “turn-out” (“tail-ditch”) should coincide with the outlet location of a cross-drain culvert to “dump” transported and accumulated water from the receiving ditch. Where private roads and driveways intersect public roadways, install culverts to maintain continuity of flow within the ditch while allowing access across the ditch. In cases of no head wall, install enough culvert to extend each end at least two (2) feet past the toes of the road bank slopes. Install energy dissipating structures and/or armor at the outlet where scour and erosion are likely to occur from high exit velocity due to steep culvert installation, near proximity to ditch banks, drops at the end of the culvert, etc. (See Chapter 4 on OUTLET STRUCTURES). Establish and maintain at least one foot of road bed cover over all culverts. Two feet or more cover is the desired optimum.





Exhibit 3.1a - Culverts for Stream Crossing



Exhibit 3.1b - Culverts for Crossing Natural Drains

**Exhibit 3.1** - Culverts for Crossing Natural Streams and Water Courses



**Major Cross Drains**



These usually facilitate large drainage areas which may include a network of roadway ditches, field drains, etc. and often discharge at a point in or near a natural stream or drainage.



**Intermittent Cross Drains**



These usually connect road ditches on the upland side of a roadway to road ditches on the opposite side, or convey water to discharge points on the opposite side of a roadway.



**Miscellaneous Cross Drains**



These maintain continuity of flow by connecting or re-connecting road ditches which have been crossed by an intersecting road or driveway, or simply provide for drainage under roads and driveways. Also, note the need for scour protection at the outlets. This is a significant source of sedimentation.

### **Exhibit 3.2 - Runoff Management Culverts**

---

### *Maintenance At Sensitive Aquatic Environment Crossings*

---

Inasmuch as possible, maintain pre-existing conditions in streams when performing maintenance on culverts for stream crossings. Avoid impedances to fish and other aquatic fauna by adhering to the following:

- a. Contact the state fisheries biologist or the U.S. Fish and Wildlife Service (USFWS) for assistance.
- b. Do not substantially alter water velocities. Especially do not create excessive velocities. Keep in-pipe velocities within those navigable by fish.
- c. Do not create vertical barriers.
- d. Do not create adverse water depths. Keep in-pipe flow depths comparable to those of the associated stream channel.
- e. Do not create flows outside the range of flows normally encountered throughout the year, or at least those flows which may negatively impact the aquatic life in the stream.
- f. Make sure the culvert design accommodates the size and species of fish passing through it.
- g. Provide resting pools at culvert inlet and outlet for culverts installed across streams with high channel gradients.
- h. Use corrugated culverts to decrease water velocities through the culvert and supply resting areas for migrating fish.
- i. Use bridges, bottomless arches, partially buried culverts, or other similar structures in areas where fish passage and specie habitat is an important consideration.
- j. At stream crossings, select a culvert site where there will be no abrupt change in gradient and the upstream and downstream channel alignments are as straight as possible for 50 feet in either direction.
- k. Consider maximum design flows which will not create adverse stream conditions.

## FISH FRIENDLY DESIGNS

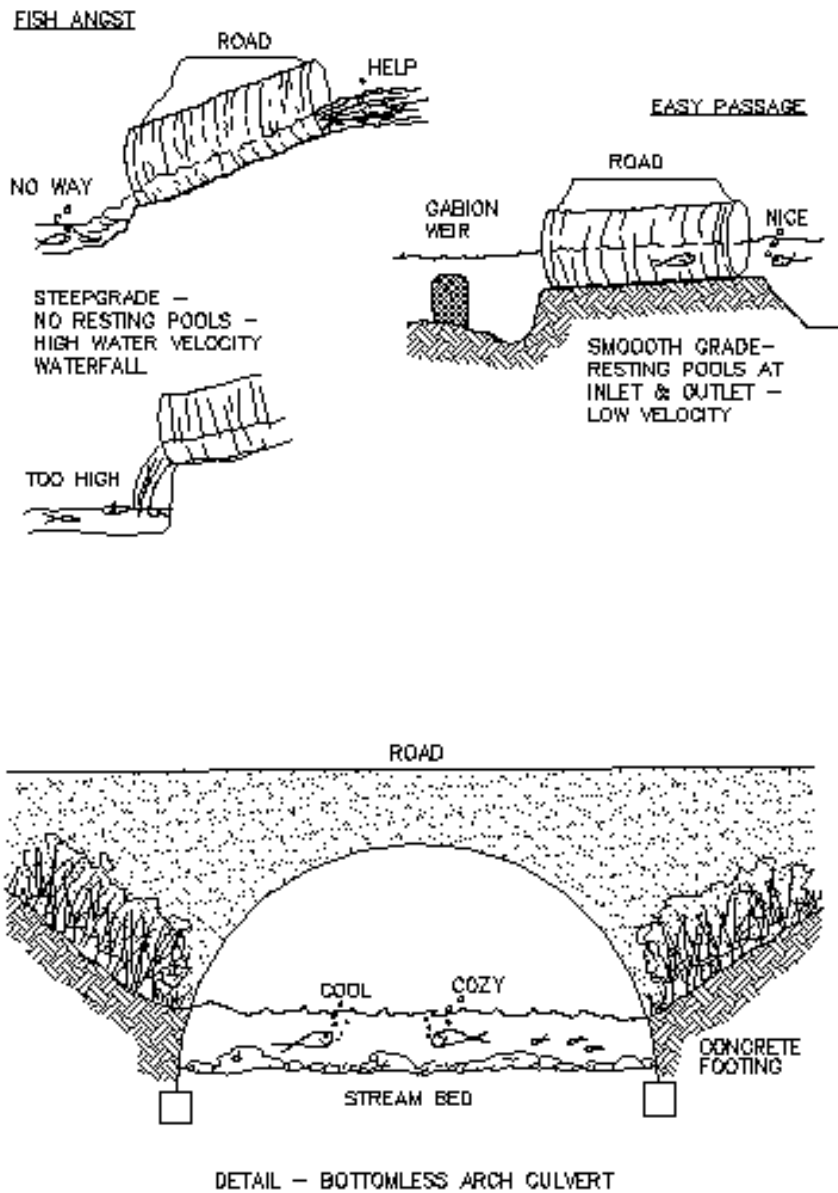

Figure 3-1. Examples of Fish Friendly Designs

---

### ***Culvert Installation/Replacement***

---

In live (flowing) streams install sandbags, silt fences, earthen dikes, or other appropriate measures to inhibit flow when possible. Use a pump to convey water around the excavation/work site. Discharge pumped water onto a stable outlet to prevent scour. With live stream flows which cannot be impounded, divert the flow to one side of the culvert alignment. Enough room should be allowed to properly excavate the entire pipe trench and bed the entire culvert. Minimize disturbance of the surrounding soil and vegetation.

Excavate trench side slopes on a safe grade to prevent caving. Inasmuch as possible, the bottom of the trench should be at least twice the width of the culvert to be installed and graded as near to designed culvert grade as possible.

One method of properly installing a culvert is to start at the outlet end, lay the culvert up-slope, properly bedding each joint as installation proceeds. The first section or “joint” is critical, and special attention should be given to proper installation, grade, and alignment to reduce the potential for scour and erosion from water discharge, and, to ensure the whole culvert is aligned properly. Pipe joints should be wrapped 1-1/2 times around with geotextile filter fabric. The fabric should extend at least two feet either side of the joint or edges of the connecting band if one is used. This is especially true with concrete or other types of pipes which may not have rubber or mastic seals at the connecting joints. Once the culvert is installed and secured in place, divert the flow through the culvert and commence filling the by-pass channel, if any, and complete the backfilling around the culvert. Backfill around and over the culvert should be placed evenly and level in maximum 12" loose lifts and thoroughly compacted before adding successive lifts. Scarify (roughen) the top two inches of compacted surfaces which have a slick, smooth, or glossy finish after compaction. Six (6) inch loose lifts should be used below the midpoint of the culvert. Do not use or operate machinery closer than two feet of the culvert.

Mulch and vegetate all disturbed areas. Use silt fences or other appropriate erosion control measures to prevent or reduce erosion and sedimentation until stabilizing vegetation is established.

---

### ***Head Walls (Headers)***

---

Head walls may be used when hydraulic capacity needs to be increased, and/or when installing a head wall will be more efficient than culvert replacement. Head walls should be flush with the end of the culvert. Head wall “wings” (extensions) help mold and direct channel flow into the culvert and protect the area around the inlet from scour. Head walls may be of poured concrete, bagged concrete, concrete blocks, bricks, logs, cut wood, or may be shaped loose rock riprap, etc.

---

### *Cleaning and Maintenance*

---

One method to account for all culverts is to maintain an inventory of culverts and under-drains and use a checklist from this inventory to account for culverts during inspections. Inspect culverts often, especially in the spring and autumn, and after storm events, checking them for signs of corrosion, joint separation, bottom sag, pipe blockage, piping, fill settling, cavitation of fill (sinkhole), sediment buildup within the culvert, effectiveness of the present inlet/outlet inverts, etc. Check inlet and outlet channels for signs of scour, degradation, aggradation, debris, channel blockage, diversion of flow, bank and other erosion, flooding, etc.

Practice preventive maintenance to avoid clogging of pipes and other situations which may damage the culvert or diminish its design function. If a culvert is plugged with sediment, flush it from the outlet end with a high pressure water hose. Take measures to reduce downstream sedimentation and clean debris and sediment from the outlet ditch afterwards.

When replacing damaged culverts which handle the flow adequately, use the same size, shape, and type of pipe. Changing any of these criteria may adversely effect the established stability of the ditch, stream, and/or roadway.



Culvert head walls come in many shapes, sizes, and materials.



Head walls can stabilize culvert outlets and entrances and improve flow efficiency at inlets.

**Exhibit 3.3 - Head Walls (Headers)**

## Chapter 2

# DITCHES

---

### Description

Ditches are constructed to convey water from storm runoff to an adequate outlet. A good ditch is shaped and lined using the appropriate vegetative or structural material and does not cause flooding, erosion, or sedimentation. Energy dissipating structures to reduce velocity, dissipate turbulence, or to flatten flow grades in ditches are often necessary.

### Importance to Maintenance & Water Quality

Efficient disposal of runoff from the road will help preserve the road bed and banks. Well vegetated ditches slow, control, and filter runoff providing an opportunity for sediments to be removed from the runoff water before it enters surface waters. In addition, a stable ditch will not become an erosion problem itself. Ideally, “turn-outs” (intermittent discharge points also called “tail ditches”) will help maintain a stable velocity and the proper flow capacity within the road ditches by timely outleting water from them. This will help alleviate roadway flooding, reduce erosion, and thus reduce maintenance problems. In addition, properly placed “turn-outs” help distribute roadway runoff and sediments over a larger vegetative filtering area, helping to reduce the amount of road ditch maintenance required to remove caught-up sediment.

### Ditch Profile and Grading

---

#### *General*

---

Roadway ditch location, profile, shape, lining and outlets effect how efficiently water will be removed from the roadway. Ideally ditches should resist erosion, be self cleaning, and discharge onto nearly level vegetated areas, thus maximizing the length of time between regrading, thereby reducing maintenance costs. As shown in figure 2-1, ditches should be located on the uphill side of the roadway to prevent runoff water from flowing onto and over the road surface.

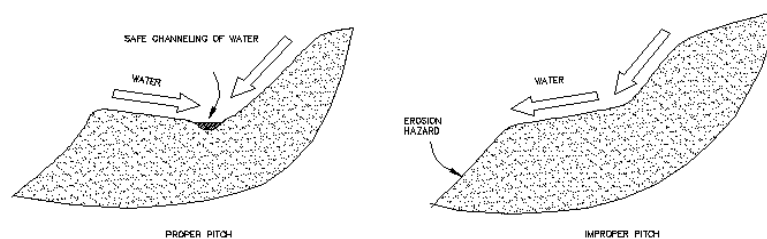

Figure 2-1. Hillside Pitch of Roadway and Proper Ditch Location



Excavate roadway ditches at a bottom elevation 1 to 2 feet below the road base. The ditch bottom should be rounded-V shaped (preferred), parabolic, or flat, as shown in figure 2-2, and at least 2 feet wide to disperse the flow and slow the velocity. Do not construct U-shaped ditches. U-shaped ditches actually have up to 30 percent less drainage capacity than other shapes and they tend to look messy. Their steep sides make maintenance difficult and the sides tend to cave in, compounding maintenance problems and adding to erosion and sedimentation.

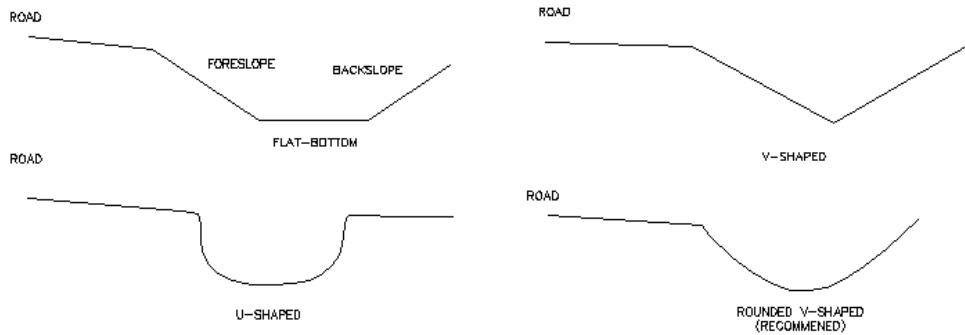

Figure 2-2. Common Ditch Shapes

Where possible, install “turn-outs” (“tail-ditches”) to help maintain a stable velocity and the proper flow capacity within the road ditches by timely outletting water from them. See Figure 2-3 below. These structures are critical elements in establishing and maintaining a stable unpaved roadway drainage system. It is imperative that landowners adjacent to these roadways allow water to be discharged in this manner at crucial points. Correspondingly, these turn-out points must be stabilized to prevent creating worse erosion problems such as gullies. In many cases, the discharged runoff can be spread to reduce the erosive energy of concentrated flows.

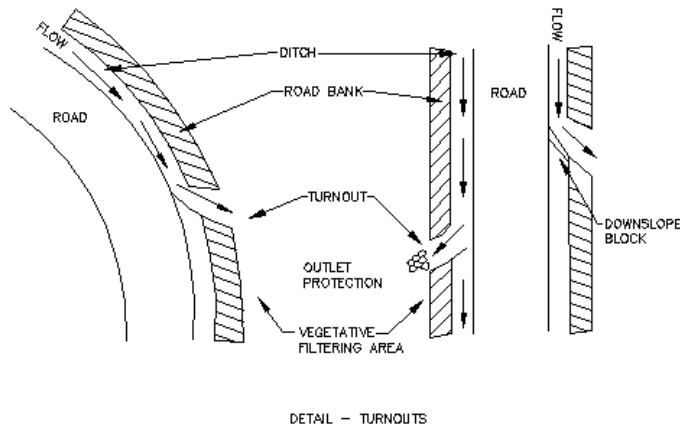

Figure 2-3. Typical Locations for “Turnouts” (“Tail Ditches”)



No ditch on the uphill side of the roadway can allow runoff to overflow the roadway. This leads to surface erosion of the roadway, such as these corrugating rills, and often to complete washouts. Road surface overflow is a significant contributor to sedimentation, especially during high runoff events.

### Exhibit 2.1 - Proper Ditch Location



Flat Bottom (Trapezoidal) Shaped Ditch



V-Shaped Ditch



U-Shaped Ditch



Rounded V-Shaped Ditch

### Exhibit 2.2 - Common Ditch Shape Examples



Motor graders can be used to create and maintain tail ditches, however, backhoes and dozers can be more efficient and leave much less loose and disturbed soil which is easily and readily washed out.

### Exhibit 2.3 - Tail Ditch/Turn-Out Construction with a Motor Grader



Turn-out to a drop inlet.



Turn-out at gradient changes.



Turn-out before bridges.



Turn-outs into filtering areas.



Turn-outs/Tail ditches outlet water from roadway ditches to maintain a stable flow volume and velocity within the ditches. They can be placed at specific and selected sites to protect down gradient structures such as bridges and culverts, or to utilize specific erosion control or storm water discharge facilities.

### Exhibit 2.4 - Turn-outs/Tail Ditches

Line ditches which have a channel slope less than 5% with grass, and line those which have a 5% or greater channel slope with geo-fabric or aggregate filter underlain riprap or other material (*Concrete lining is not recommended on unpaved roads in the CPYRWMA area due to the highly erosive sandy soils and the potentially volatile nature of unpaved road degradation during intense storms common to this area*). Line ditches as soon as possible to prevent erosion and to maintain the ditch profile. Whenever possible, excavate ditch only as far as lining can catch up before the next expected or potential rainfall event.

All ditches should have appropriate outlets which allow water to completely drain from them. Standing water in ditches against road fill weakens the roadway. The preferred equipment for creating ditches is a rubber-tired excavator with an articulated bucket. A well designed and constructed road ditch can be cleaned with a grader or excavator making maintenance quicker, easier, and less costly.

---

### ***Other Applications***

---

Diversion ditches and berms may be used as structures to intercept, consolidate, and direct or redirect runoff at the top of a slope to prevent gullies and rills on slopes, or across the slope to break up the slope length or redirect water flow. These ditches and berms should be located where the outlet will empty onto a stable disposal area. Ditches and berms may be used in combination where runoff is significant and/or hard to control.

---

### ***Cleaning & Maintenance***

---

Check all ditches, including “tail-ditches” and “turn-outs”, after major storm events, as the storms may have caused obstructions, erosion, or bank collapse. Have a post-storm plan for checking for damage and determining maintenance needs.

Clean out ditches, when they become clogged with sediments or debris, to prevent ponding, bank overflows, and road washouts. Re-grade ditches only when absolutely necessary and line with vegetation or stone as necessary. Re-grading of ditches should be limited to late spring or summer, after spring rains have diminished and drier weather has set in, and when vegetation can re-establish itself. Other times may be suitable depending on weather patterns, work to be performed, and exigency of work to be done. The main concern is to limit disturbance to the ditches during times of high erosion potential.



# *Chapter 1*

## **ROAD SURFACE**

---

### **Description**

Unpaved roads carry local traffic between rural lands and communities, and provide connecting links between paved collector roads. More than 25 % of the roads in the Choctawhatchee, Pea, and Yellow River watersheds have an unpaved or gravel surface. Most of these roadways consist of sandy to sandy clay loam soil material. These roadway surfaces and ditches are subject to erosion and degradation which lead to sedimentation within watercourses, streams, and rivers.

### **Importance to Maintenance & Water Quality**

Disturbances to unpaved roadway surfaces and ditches, and poor road surface drainage always result in deterioration of the road surface. This deterioration is the erosion which accounts for a large percentage of unpaved road maintenance costs and stream sedimentation. Frequent, excessive, and unnecessary disturbances to the roadways are all too common because of political pressure from the public to continually blade roads, and the common practice of wholesale blading adopted by administrators and operators over the years. Proper and timely surface maintenance, selectively performed, will help reduce the amount of roadway being disturbed, and will reduce the amount and frequency of disturbance to the section of roadway requiring maintenance.

Proper, timely, and selective surface maintenance, which includes water disposal, prevents and minimizes erosion problems, thereby lengthening the life of the road surface which in turn lessens frequency and cost of maintenance. This will also decrease the amount of sediment carried into surface waters. Frequent and excessive disturbance of the roadway surface and ditches, and failure to direct surface water from the road surface to a drainage channel results in deterioration of the road surface, which leads to other roadway problems which may impair traffic flow and traffic safety, among other things.

### **Surface Profile, Grading, and Drainage Characteristics**

---

#### *General*

---

Do not disturb roadway sections which *do not* need maintenance while repairing, blading, or grading those sections which do. When routine maintenance is being performed, limit the amount of disturbed areas to that which can be re-established to the desired final shape by the

end of the work day. To minimize opportunity for degradation of the roadway, it is best not to blade, grade, or drag if rain or freezing temperatures are favorable within the 48 hour forecast. As much as possible, avoid non-essential or non-emergency work near streams or stream crossings during the “wet” months of the year. Save this work for drier seasons.

It is best to limit roadway blading to times when there is enough moisture content to allow for immediate re-compaction. Often, an optimum time for this is soon after a rain while the surface materials are still moist but not too wet. Blading with little moisture content in the soil is futile, and is often a causative factor in road surface degradation such as “washboarding” and other problems associated with loss of fines.

As shown in figure 1-1, crown roads  $3/4$  to 1 inch for each foot of road width, measured from the center of the roadway to the outside edge, to ensure good drainage. Roads in deep loose sands may be crowned  $1/4$  inch or less for each foot of road width from center of the roadway to the back of ditch. In this instance, there is no defined ditch front slope due to the excessively erosive nature of the sand. Rather, the extra road width provides drainage at the outer edges of the roadway. Proper crowning and compacting of the road surface quickens the removal of runoff, thus protecting the road surface from degradation.

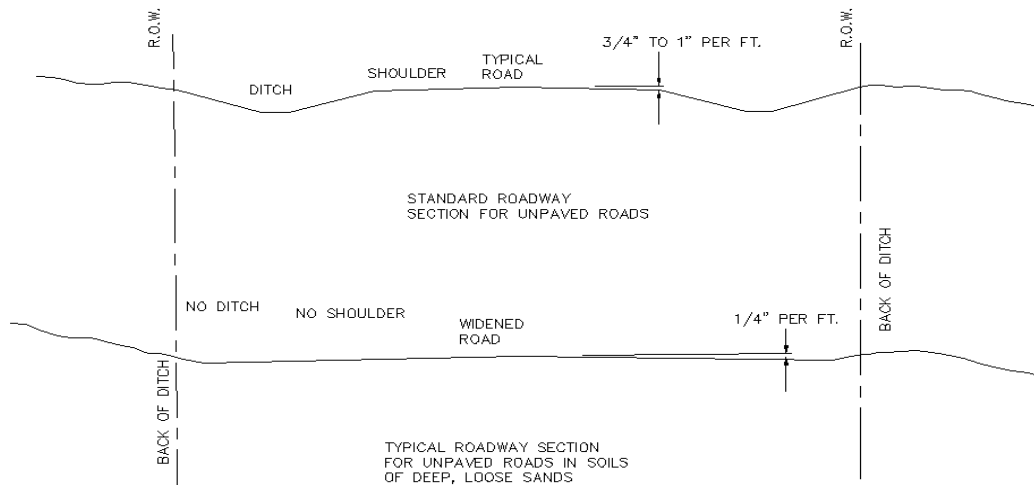

Figure 1-1. Typical Sections - Unpaved Roadway



Exhibit 1.1a - Examples of 3/4" to 1' crown with road ditches in place. Water sheds readily off the crowned road surface and into the ditches. Proper drainage off the roadway surface helps to maintain a good "crust" which stabilizes the roadway and helps provide a good riding surface.



Exhibit 1.1b - Examples of 0" to 1/4" crown with no road ditches in place. Water infiltrates the soil of the sandy and flat road surface minimizing runoff from the roadway. The water that sheds from the roadway is readily removed from the road surface into the roadway edges allowing a passable lane in the center of the roadway.

**Exhibit 1.1 - Typical Crowns and Sections Of Unpaved Roadways**





Proper moldboard forward tilt for blading.



Proper blade angle and wheel lean.

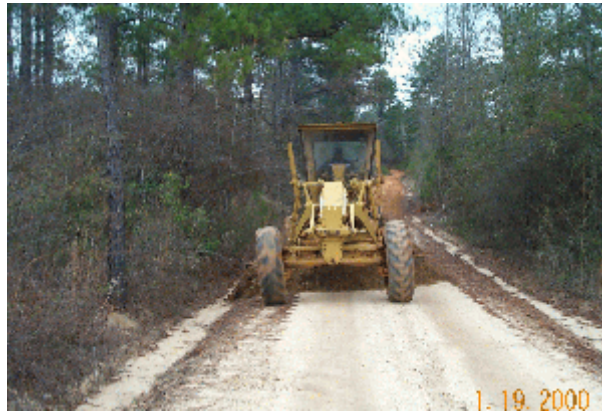

Unnecessary Blading. Road is adequate.



Rutted, weathered, and rough surfaces require blading. Blading shaves high spots and fills low spots.

**Exhibit 1.2 - Blading**

---

## *Performance*

---

### Blading and Dragging

---

Blading and dragging is a smoothing operation which pulls loose material from the side of the road or spreads wind-rows of aggregate to fill surface irregularities and restore the road crown. It is performed with the moldboard tilted forward with light down pressure on the motor grader blade as shown in figure 1-2. The angle of the moldboard is adjusted to between 30 and 45 degrees, and in most cases, the front wheels are tilted slightly 10 to 15 degrees toward the direction the aggregate should roll.

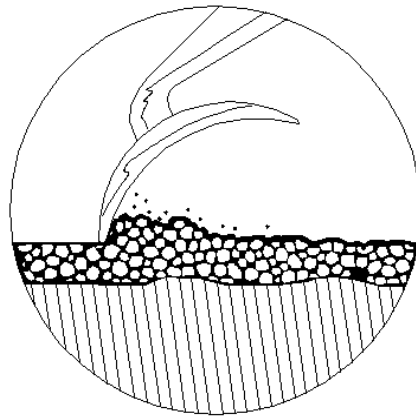

TILT MOLDBOARD  
FOR DRAGGING ACTION

*Figure 1-2. Blading*

The following should be adhered to when blading:

- a. Avoid blading during extended dry periods to minimize the loss of fine aggregates and minimize “washboarding”.
- b. Blading/dragging speed depends on the operator’s skill, type and condition of machine (grader), tire pressure, and road surface condition. Normally, **three miles per hour in second gear is advised**.
- c. Periodically blade the road surface against traffic flow to prevent aggregate from drifting onto ends of bridges, culverts, intersections, and railroad crossings. This is commonly referred to as “back dragging”.

- d. On hill crests, avoid cutting into the road surface, gradually adjusting the blade up as the front wheels pass over the crest and then down as the rear wheels follow (figure 1-3a).
- e. In valleys or swags, gradually adjust the blade down as the front wheels pass the lowest point and then adjust the blade up as the rear wheels follow. This will prevent loose, easily erodible materials from piling up where runoff and concentrated flows frequently occur, thus preventing loss of valuable road fill, and preventing massive sedimentation to local streams and waterways (figure 1-3b).

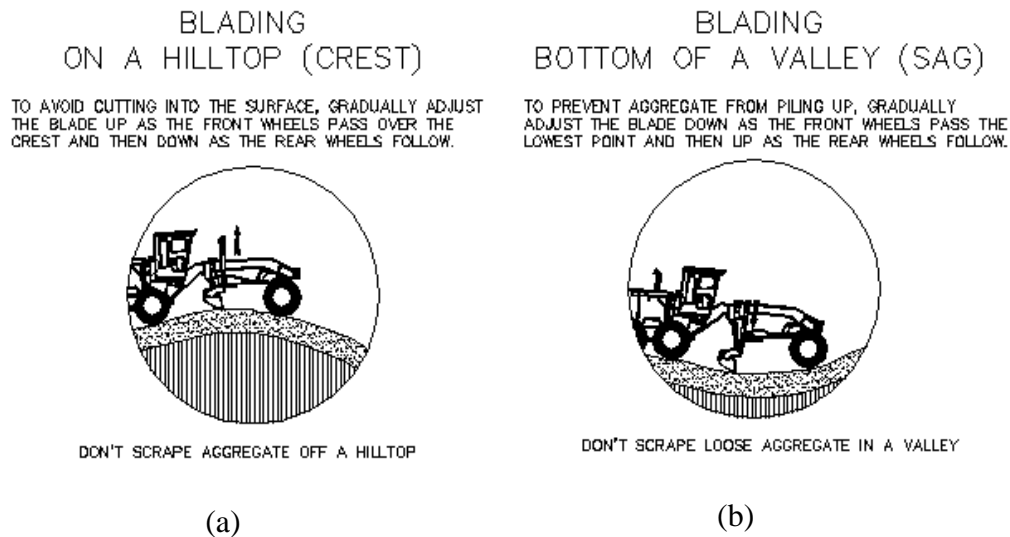

*Figure 1-3. Blading on Hill Crests and in Valleys or Swags*

---

## Reconstructive Grading

---

Reconstructive grading consists of cutting through, redistributing, and re-compacting the road surface crust, and/or adding new road fill material to obtain the desired roadway shape and profile. This method is used when reshaping the roadway or when the correction of major surface defects such as deep ruts, soft spots, severe erosion, etc. is necessary. Figure 1-4a shows motor grader cutting operations performed with the moldboard tilted backward with sufficient down pressure on the blade to produce a cutting action. Breaking the crust with a scarifying rake may be required before moldboard work can be performed (see figure 1-4b).



Deep rutting often requires grading work. Such ruts are frequently caused by heavy machinery such as farm equipment and feed trucks.

**Exhibit 1.3 - Grading**

Clay surface layer placed over sandy roadway surface



Clay blended into roadway surface with scarifier and blade



Aggregate blended into clay surface layer with scarifier



**Exhibit 1.4 - Grading Using Scarifier and Blade**

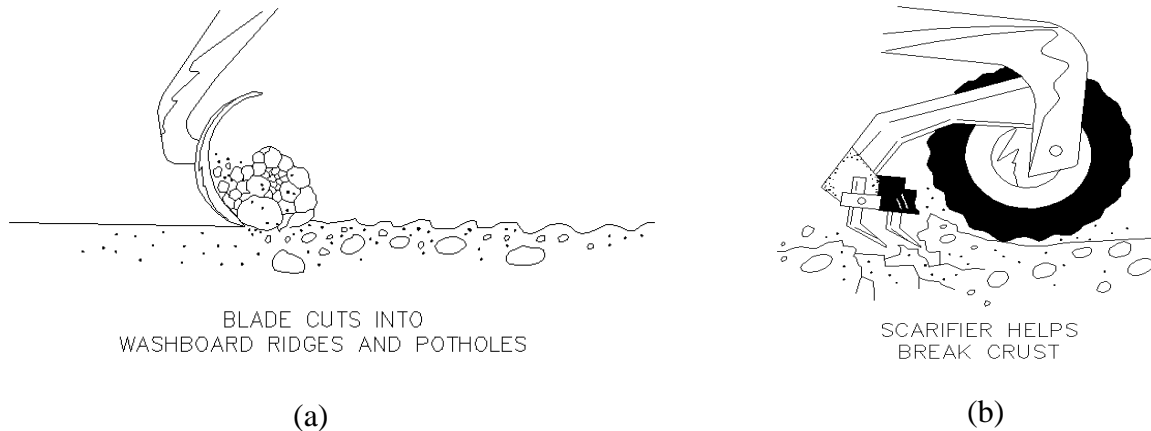

*Figure 1-4. Grading Tools*

The following should be adhered to when grading:

- a. Perform grading cutting operations with the outer edge of the moldboard at the road surface's edge.
- b. If the road ditch is not to be re-worked along with road grading operations, keep a minimum of one foot from the ditch line so that vegetation or rock stabilization is not disturbed. In this case, grading work must always bring the road surface back up to and slightly above the ditch line elevation to allow road surface runoff to flow into the ditch and not create a *false ditch* down the roadway (figure 1-5).

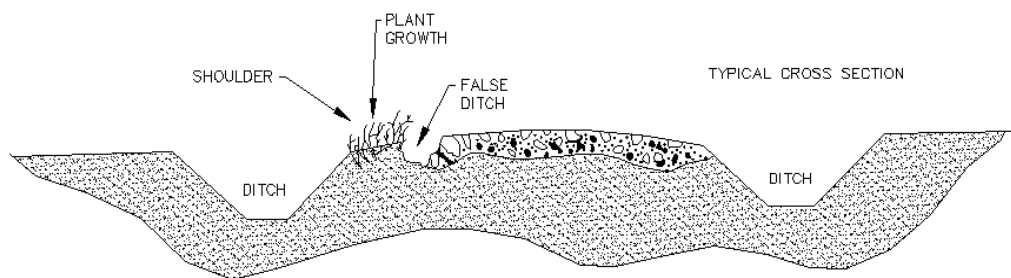

*Figure 1-5. False Ditch*

- c. Lightly scarify the existing road surface before adding new material. This blends the soils and improves cohesion.
- d. Adding new material should be done by running the dump truck down the center of the

roadway and dumping as it travels. The new material should then be blended with the scarified old material using a grader, and compacted.

- e. To reduce potential roadway degradation, the entire width of the of the roadway disturbed by grading should be compacted by the end of the day.
- f. Positive drainage to road ditches or other outlets must be established throughout the entire finished road surface.

## Distress Conditions

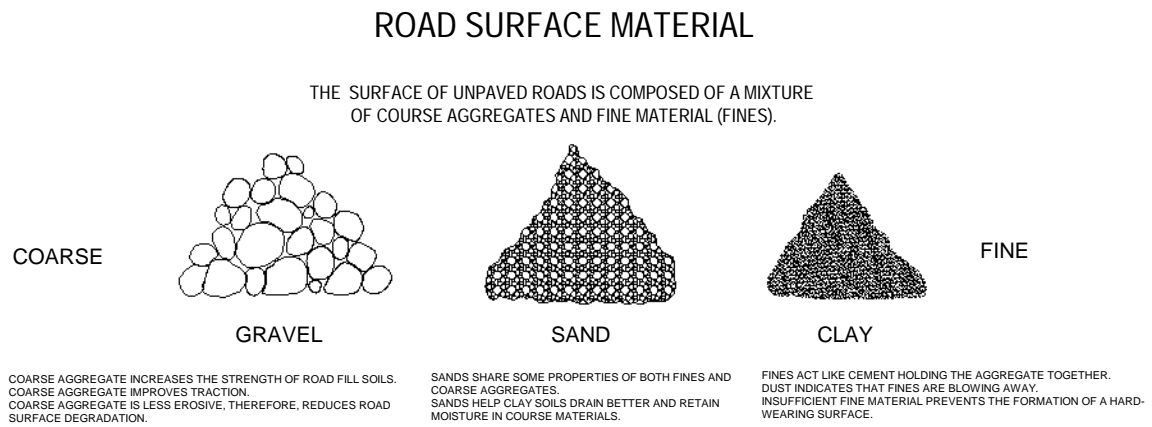

*Figure 1-6. Aggregate Comparison*

---

### *Surface Deteriorations*

---

#### Dust

---

Dust in the air is a loss of fine, binder aggregates from road surfaces. Loss of these fines leads to other types of road distresses such as loss of cohesion and compaction of the road fill material, and reduced capacity to maintain moisture in the road fill. These deficiencies also tend to feed on themselves, compounding the problems - especially the lack of moisture within the road fill. Mechanically adding water to the road surface for dust control is a very short-term, expensive, and infeasible solution. In some cases, dust can be reduced by applying chemical additives which draw moisture from the air to improve fine aggregate cohesion, however, this also can be an expensive solution and may be feasible only in the most severe cases.

---

## Ravelling

---

Ravelling is the loss of coarser aggregates. This is brought about when the coarser aggregates are worn away by traffic after fine, binder aggregates have been lost due to dust or erosion. Correct by grading or blading with the addition of fines or other binder to improve surface gradation and composition.

---

## Slipperiness

---

Slipperiness is caused when the road surface contains excessive fine aggregates in proportion to coarser aggregates, especially within the crust. Traffic wear can reduce coarse aggregates to finer aggregates, thus dis-proportioning the original road fill aggregate mix. During wet weather, the road surface becomes slippery and may become impassible. This problem can be corrected by mixing the surface fines with coarser aggregate by grading and/or blading the road surface and compacting back in place. Occasionally, coarser aggregate will need to be hauled in and added to the roadway.

---

## *Surface Deformations*

---

Surface deformation problems are almost solely the end result of excessive moisture in the road fill and thus can be reduced with proper road surface and road ditch maintenance.

---

## Rutting

---

Ruts are longitudinal depressions in the wheel paths caused by high moisture content in the subsurface soil or base, inadequate surface course thickness, and /or heavy traffic loads. Rutting can be corrected by adding suitable material, grading, crowning, and rolling the road surface. Do not simply fill ruts with stone or soil. Filing ruts with stone can lead to new ruts being generated beside the original ones and thus would be an expensive and temporary “fix” which can also interfere with grading. The surface must be re-mixed and properly bladed or graded in more severe cases.

Areas of sustained and repeated rutting may require more severe measures. An elaborate drain system and/or geotextile fabric foundation with a crushed stone road fill may be used to correct severe rutting problems.



---

### Corrugating/“Washboarding”

---

Corrugating/“washboarding” is a series of ridges and depressions across the road surface caused by the lack of surface cohesion. This lack of cohesion is a result of the loss of fines in the road surface which, in turn, is usually a result of very dry conditions within the road surface. These conditions are aggravated and enhanced by excessive vehicle speeds and high traffic volumes.

Where surface fines are segregated from coarser aggregates, blading with sufficient moisture content can repair the road surface. When the causative problem is of loss of fines, blading alone is not recommended. The problem will only recur shortly thereafter. The problem is best corrected by scarifying the road surface while damp, thereby re-mixing the road surface with a good percentage of fines, regrading, re-establishing the crown, and compacting the surface.

---

### Depressions

---

Depressions are localized low areas one or more inches below the surrounding road surfaces caused by settlement, excessive moisture content, and improper drainage. These are larger areas not to be confused with potholes.

Depressions should be corrected by filling them with a well-graded aggregate, then grading the effected road surface, and compacting. Underdrains or cross drains may be necessary to improve drainage and prevent recurrence.

---

### Potholes

---

Potholes are small depressions or voids in the road surface one or more inches deep which are caused by excessive moisture content, poor drainage, poorly graded aggregate, or a combination of these factors. Potholes may be corrected by patching with well-graded materials and compacting, and/or spot grading. Large areas of potholed road surface indicate a poor road fill condition over an extended section of roadway, and thus may require the re-grading, re-crowning, and re-compacting of the affected roadway section to mix aggregates into a well-graded road fill and improve road surface drainage. Underdrains may also be necessary in these areas to drain the sub-grade.

---

### Softspots

---

Softspots are areas of the road surface and/or sub-grade made weak by poor drainage. These areas depress under vehicular weight and almost always develop one or more of the other types of surface deformations. These areas can be corrected by improving drainage conditions or



False ditch created by vegetal impediments



False ditch created by shoulder traffic and rutting



Washboarding



Slipperiness



Rutting

**Exhibit 1.5 - Roadway Surface Problems**



Soil stockpile located on the crest of a hill where runoff is minimal



Soil stockpiles located on a well vegetated hillcrest and away from concentrated flow channels

**Exhibit 1.6 - Storing and Stockpiling Soil Materials**

replacing the soft spot with more drainable materials. Depending on the cost effectiveness and feasibility of each, the following methods may be used to correct soft spots:

- a. Improving the drainage of the road fill and/or sub-grade with underdrain. This method is outlet dependent.
- b. Improving the drainage of the road fill and/or sub-grade by grading road ditches low enough to remove water from beneath the problem area. This may involve piping to move water from one side of the road to the other. This method is outlet dependent.
- c. Patching the soft spot area with a suitable material such as well-graded stone or gravel.
- d. A combination of the above.

---

### ***Storing and Stockpiling Soil Materials***

---

Improper storing or stockpiling of soil material can increase the amount of sediment that enters streams and damage sensitive areas, particularly wetlands. Soil materials should not be placed in or along wetlands, drainage ditches, swales, streambanks, areas within 50 feet of (and drain into) a waterway, and against slopes that are more than 2 horizontal to 1 vertical. Always ensure the area down slope of the storage area has an adequate vegetated filter strip to trap sediments, or use a properly installed and maintained silt fence or other barrier. Seed or vegetate any fill or spoil disposal areas as soon as possible.

Plan erosion-safe storage and stockpiling areas ahead of time, especially in the winter and early spring when rainfall can be high and vegetative cover minimal. Level to gently sloping, grassed areas usually provide good storage sites. Hilltops, ridges, and inactive or active borrow pits also often provide good sites. These planned storage areas will help reduce sedimentation and will also provide the opportunity to utilize these materials later when needed for roadway repairs. This can reduce overall maintenance costs by saving fill material and making it conveniently and readily available. Figure 1-7 illustrates proper stockpiling techniques of soil materials.

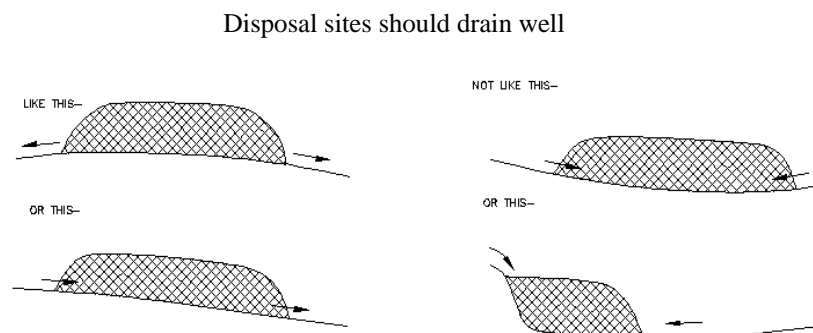

*Figure 1-7. Soil Material Storage Site Configuration*

