

BOTCAM

Design, Testing and Development of a Fully Automated Stereo-Video Bottom Camera
Bait Station for Ecosystem Monitoring of Bottom Fish Species

**A PAPER SUBMITTED TO THE GRADUATE DIVISION OF THE
UNIVERSITY OF HAWAII IN PARTIAL FULFILLMENT OF THE
REQUIREMENTS FOR THE DEGREE OF**

**MASTER OF SCIENCE
IN
OCEAN AND RESOURCES ENGINEERING**

DECEMBER 2005

By

Daniel W. Merritt

Committee:

John Wiltshire, Chairperson
Geno Pawlak
Chris Kelley

We certify that we have read this paper and that, in our opinion, it is satisfactory in scope and quality as a paper for the degree of Master of Science in Ocean and Resources Engineering.

THESIS COMMITTEE

Chairperson

Acknowledgements

Throughout the course of this project, I was assisted by many people to whom I'm forever grateful. My committee chairman John Wiltshire was a source of great advice from the early stages of planning right through the defense. I thank committee member Geno Pawlak for not only his assistance with this thesis, but also for challenging me throughout my coursework. Special thanks and recognition go to committee member Chris Kelley. Without Dr. Kelley's knowledge and support, this project never would have been possible.

I thank the entire Ocean and Resources Engineering Department, students, faculty and administration. In particular, I would like to recognize Department Chair Dr. K.F. Cheung and our Department Administrator Edith Katada for their help in getting me through the entire process involved in graduating.

Several people at the Coral Reef Ecosystem Division participated in this project. Division chief Rusty Brainard championed this project and kept it alive for a number of years. Project principle investigator Michael Parke dealt with a number of administrative issues and CRED Administrator Marcia Oschiro was helpful in countless ways. Kevin Wong deserves special recognition. He has been an outstanding boss and mentor to me and has worked very hard on this project as well. The oceanography team of Ron Hoeke, Jaime Gove and Kyle Hogrefe not only helped me directly with this project, but picked up much of my slack with my oceanography responsibilities to allow me to focus on this project. The CRED fish team of Brian Zgliczynski, Joe Laughlin and Stephani

Holzwarth supported this project from the start. Special thanks to Joe Laughlin who was especially helpful. Several members of the marine debris group were a tremendous help down the stretch including Chip Young, Todd Wass, Josh Slater, Kevin Lino, Eric Dobbs, Ann Mooney, Jeremy Jones and Kyle Koyanagi. Finally, thanks to my office mate Molly Timmers who provided a number of the maps contained in this report and kept me sane throughout this process.

Frank Parrish and Rob Dollar of the PIFSC were instrumental in many ways getting this project completed. The extensive field work done around Oahu could not have been completed without the help of Bo Alexander of HURL or Rob Wennihan of Cates International. Several Vendor played key roles in the development of this project including the entire team at Deep Development Corporation, Ken Sexton of Sexton Photographics, Dave Brem of Subsea Sonics, Beto Campos of Remote Ocean Systems, Brock Rosenthal of Ocean Innovations, Mike Chapman of Mecco Inc. and Mark Shortis of Geomsoft. Dr. Euan Harvey from the University of Western Australia has been a key figure in development of our stereo-video system and has spent a number of hours working with us.

Finally, I need to thank my friends and family who have supported me throughout this process. Support from Rebecca Scheinberg, Dan Hoover, Jenn Brum and Nicole Lautze was especially important to me over the past few months. And to my parents, Bill and Carlin Merritt, sister Carrie Merritt and brother-in-law Chris Grubb, I am forever in your debt.

Abstract

The Coral Reef Ecosystem Division (CRED) of the Pacific Islands Fisheries Science Center (PIFSC) has developed a remote camera bait station (BotCam) to be used as an independent, in-situ, ecosystem-based tool for fisheries research and management. The device was designed to monitor commercially important bottomfish species within the Hawaiian Archipelago, American Samoa, the U.S. Line and Phoenix Islands, the Marianas Archipelago, Johnston Atoll and Wake Atoll. Previous work done within the science center and in various collaborations with the center have shown bait stations to be effective instruments for monitoring fish stocks. The unit presented is the first of its kind to implement a stereo-video system capable of capturing video at depths up to 350 meters with no external light source. The system is fully automated and can be deployed and recovered from a variety of vessels, capturing up to four hours of high resolution stereo-video digital files.

Building on work done over the past year on a first prototype, the design, fabrication and testing of a second prototype incorporating a stereo-video system for accurate measurements of both fish and benthic features was achieved. Based on the findings from the second prototype, a third prototype has been designed and is currently being tested. Further, a preliminary study of the unit's bait dispersal characteristics using visual cues was performed. Understanding the area affected by the bait is one of the keys to making bait stations an effective fisheries research and monitoring tool.

TABLE OF CONTENTS:

Acknowledgments	iii
Abstract	v
List of Tables	viii
List of Figures	viii
1.0 BACKGROUND	1
1.1 Bait Station History at the PIFSC	4
1.2 Prototype I	6
2.0 PHOTOGRAMMETRY AND VISION METROLOGY SOFTWARE (VMS)	11
3.0 PROTOTYPE II DESIGN	19
3.1 Video Capture Electronics	20
3.2 Cameras	24
3.3 Frame Design	26
3.4 Acoustic Release	32
3.5 Bait Release System	34
3.6 Stereo Sync Device	38
3.7 Pressure Sensor	40
3.8 Surface Signature	41
4.0 PROTOTYPE II TESTING	45
4.1 Camera and Recorder Testing	46
4.2 Land and Tank Testing	47
4.3 Pier Testing	47
4.4 Shallow Water Testing	50
4.5 Swimming Pool Calibration	51
4.6 Full Depth Deployments	52
5.0 PROTOTYPE III DESIGN	62
5.1 Viperfish Deep	63
5.2 Stereo Video Sync (SVS)	64
5.3 Burn Wire Relay (BWR)	64
5.4 Surface Signature	65
5.5 Frame Design	66

6.0	RESULTS AND CONCLUSIONS	69
7.0	FUTURE DIRECTIONS	70
7.1	Anchoring Problem	70
7.2	Testing the stereo video precision and accuracy	72
7.3	Drive down the overall cost of units	72
7.4	Bait plume modeling using visual methods	73
7.5	Automation of analysis	83
8.0	APPENDICES	85
8.1	Appendix 1: Botcam Prototype II Frame Concepts	85
8.2	Appendix 2: Camera Comparison Matrix	88
8.3	Appendix 3: Camera Test Data	89
8.4	Appendix 4: Botcam Prototype III Fact Sheet	90
8.5	Appendix 5: Hardware, Software and Expendables	91
8.6	Appendix 6: Frame Design Drawings	97
8.7	Appendix 7: Prototype III Weight Estimates	126
8.8	Appendix 8: Anchor Calculations and Design	127
8.9	Appendix 9: VMS Simplified Users Guide	128
8.10	Appendix 10: Botcam Operations	137
8.11	Appendix 11: Target Fish List	150
9.12	Appendix 12: Bait Study	152
9.0	BIBLIOGRAPHY	157
9.1	Works Cited	157
9.2	Works Referenced	158

LIST OF TABLES:

Table	Page #
1. Errors associated with stereo-video estimates of length and width measurements of southern bluefin tuna. (Adapted from Harvey et al 2003)	17

LIST OF FIGURES:

Figure	Page #
1 Frame grab from Frank Parrish’s baited camera	5
2 Baited camera system used by Gledhill et al	6
3 Prototype I first deployment	8
4 Shallow water testing of prototype I	9
5 Simplified schematic of stereophotogrammetry principles	13
6 Schematic of idealized case	13
7 Schematic of a camera with lens distortion	14
8 VMS software interface	15
9 “Toeing In” Cameras	18
10 Prototype II testing	20
11 Schematic of deployed BotCam	21
12 Frame grab of HURL baitstation	24
13 Viperfish Deep	26
14 Frame grab of ROS and DSPL cameras	29
15 Horizontal and vertical looking bait stations	29
16 BotCam prototype II concept	30
17 BotCam prototype II front isometric	31

Figure	Page #
18 BotCam prototype II back isometric	31
19 Prototype I acoustic release anchor point	33
20 Prototype II acoustic release anchor point version 1	34
21 Ixsea acoustic release	34
22 Ixsea acoustic release deployed	34
23 Frame grab of HURL baitstation	35
24 Prototype I bait bag	36
25 Bait release system	37
26 Bait release	37
27 SVS	39
28 Seabird 39	40
29 Surface Signature	43
30 Satellite Image of Oahu, HI	45
31 ROS Navigator camera testing	46
32 SOSI prototype I camera testing	47
33 ROS Navigator camera	47
34 BotCam prototype II frame	48
35 Testing at Makai Pier	48
36 CRED Safeboat	51
37 Swimming Pool Calibration	52
38 Satellite Image of Kaneohe Bay and Windward Oahu, HI	54
39 Close up view of BotCam test locations	54

Figure	Page #
40	Frame grab of video collected at Sampan Pinnacle55
41	Frame grab showing SVS brightness at depth55
42	ROS Navigator and Watec cameras at Sampan Pinnacle58
43	Location of BotCam drop in RFA 759
44	Red Raven60
45	SVS Failure61
46	Prototype III BotCam deployed in 25 feet62
47	BWR65
48	Satellite Image of South Shore Oahu bait study sites75
49	Bait dispersal test sites76
50	Bottom Aanderaa77
51	Top Aanderaa77
52	VMS Velocity Correlations80
53	Bait Dispersal Measurement82

1.0 BACKGROUND

It is important for resource managers, researchers, and policy makers to understand the effects of management activities, such as the opening or closing of fishing areas and the allocation of catch quotas, on populations of targeted fish species. Population parameters, such as habitat utilization, rank order of abundance of different species, age class distribution, and health are critical to developing such measures, and to monitoring their effectiveness in order to develop adaptive management programs.

Due to the large variation in environmental conditions, numerous methods for monitoring fish populations have been employed by various groups. Among these methods are the monitoring of commercial and recreational catch, trawls, hook & line, traps, acoustic and visual techniques. All of these methods have inherent biases and logistical problems associated with them (Cappo et al 2002).

The generation of the data required to better understand fish populations within and adjacent to marine protected areas (MPAs) is made difficult by the need to avoid extractive or destructive sampling within these reserves. For deepwater fisheries, such as bottomfish, the task is further complicated by the preclusion of SCUBA surveys, catch and release, and other non-lethal techniques typically used in shallow water. However, periodic assessments and monitoring of these important species is required in order to support ecosystem-based management, to determine the effectiveness of MPAs, and to assess the impact of (regulated or unregulated) bottomfishing activities.

Underwater visual techniques have been used for a number of years. Methods include SCUBA diver surveys using line transects and stationary point counts, remotely-operated and autonomously-operated vehicles (ROV's and AUV's), manned submersibles, and baited and unbaited camera stations. Visual techniques allow for precise identification of both fish and habitat, they can be employed in numerous environments, and they avoid many of the biases found in trawls, hook & line and traps (Willis et al 2000, Cappelletti et al 2002, Kelley and Moffitt 2004). While SCUBA surveying techniques and protocols have been well developed over the years, time and depth are major limitations. The use of ROVs and AUVs, while promising, has limitations while operating in rugose terrain. Furthermore, their noise tends to attract some species while deterring many others (Kelley and Moffitt 2004). Manned submersibles also have their advantages, but there are relatively few available and they are very expensive to operate.

Baited and unbaited camera bait stations have been utilized by a number of groups to study various habitats (Francour et al 1999, Cappelletti et al 2002, Parrish 1989, Ellis and DeMartini 1995, Priede and Merrett 1996, Gledhill et al 1996). Camera stations have the advantage of being relatively small and quiet compared to ROVs and submersibles, and the depth and time limitations of scientific diving are not a problem. These tools are fisheries-independent and non-extractive. Furthermore, they offer an ecosystem-based approach to monitoring by allowing for accurate habitat identification and multi-species identification that are often missed with fishing surveys. Recent advances in camera technologies have made high resolution cameras available at affordable prices. Finally,

Cappo et al (2002) found that while baited cameras have an inherent bias, they were able to attract five times the number of species, both herbivore and carnivore, using bait.

The development of a deep water camera bait station for NOAA Fisheries will allow for a cost-effective and non-extractive method to assess and monitor bottomfish and other commercially important deep water species. Specifications for this system include programmable control functions which allow for the activation of imaging systems, bait release, image scaling indicators, and acoustic recovery. The camera bait station can be deployed repetitively during a survey of a site or can sit dormant on the seafloor and will activate at a pre-set time in order to maximize expensive ship time while other operations are occurring simultaneously. This flexibility in the system will allow the units to be used as a stand alone application on both small and large research vessels or as an additional tool on already busy research cruises. Further, this type of system can be used to identify benthic habitat characteristics and, given high enough resolution video, may be used to view and identify tagged fish.

The availability of a camera bait station, coupled with a standard method to analyze the image data, represents a cost-effective and non-extractive method to obtain size and abundance information on these fish populations and to study ecological linkages to more shallow water ecosystems, such as coral reefs. Statistical methods for bait station analysis were established by Ellis and DeMartini (1995). These methods allow the data collected with these tools to be used as relative abundance index in order to make temporal and spatial comparisons. These methods have been incorporated into the systems currently

used by Cappo, Harvey and others (Cappo et al 2002). Bottom camera bait stations are a tool that can assist researchers and resource managers in effectively managing stocks that frequent deepwater habitats. Such stocks may be difficult to enumerate in this near-boundary region using ship-board acoustical methods. (Wong pers. comm., Kelley pers. comm.)

1.1 Bait Station History at the PIFSC

NOAA Fisheries is one of the many state run organizations from around that world that is tasked with managing various aquatic resources that are of commercial interest. Managing sustainable fisheries is one of the primary goals of NOAA Fisheries (www.nmfs.noaa.gov). In order to do so, policy makers need solid scientific evidence of changes to ecosystems over time due to natural and anthropogenic influences such as fishing.

The use of camera bait stations by the Pacific Islands Fisheries Science Center (PIFSC, formerly known as the Honolulu Laboratory) started with unfunded work performed by Frank Parrish. In the 1980's, juvenile opakapaka were found to be living in the featureless mud flats in approximately 75 meters of sea water off the coast of Kaneohe Bay, Oahu, Hawaii (Parrish 1989). Based on this knowledge, Parrish began to study this site using several methods including fishing, bottom grab samples and scuba diving.

Parrish's next idea was to strap a piece of squid to a pole viewed by video camera, lower it to the bottom, and visualize what came to investigate. The camera housing used by

Parrish was only rated to 40 meters, however, the unit was routinely used to 75 meters. With limited resources, Parrish was therefore able to develop a new tool that was not only fisheries-independent, but that also allowed for habitat identification (see Figure 1). Parrish's work led to an influential paper on the subject (see Parrish 1989).



Figure 1. Frame grab from Frank Parrish's baited camera. Taken on opakapaka nursery grounds in 240 feet of water. Fish are puffers and juvenile opakapaka.

This project was subsequently turned over to Edward DeMartini at the Honolulu Lab who, along with Ellis developed the statistical methodologies for camera bait stations, many of which are still used by other groups today (Ellis and DeMartini 1995). In 1998, Christopher Kelley of the Hawaii Undersea Research Laboratory (HURL) and Robert Moffitt of PIFSC collaborated to develop a submersible bait station for deeper species. These bait stations, which utilized HURL's deep diving manned submersibles the Pisces IV and V, were deemed successful but was also excessively expensive. As a result of this work, an inexpensive, scalable solution was sought. Figure 2 below is an example of a baited camera system used the Southeast Fisheries Science Center.



Figure 2. Baited Camera System Used by Gledhill et al (Southeast Fisheries Science Center) in the Gulf of Mexico.

1.2 Prototype I

In 2003, the Coral Reef Ecosystem Division (CRED) of the Pacific Islands Fisheries Science Center (PIFSC) was funded to develop a remote camera bait station. A request for proposal (RFP) was submitted and a design proposed by Sound Ocean Systems, Inc (SOSI) was accepted (The specifications for this RFP can be found in Wong 2003). These specifications were largely developed from previous work done at PIFSC by DeMartini, Moffitt and Parrish. A complete list of the Hawaiian target species is listed in the appendix, however, of particular importance is a few commercially and recreationally fished snapper species and the Hawaiian grouper. Habitat for adults of these species is found between 150 and 350 meters. Similar species are found in other U.S. Pacific waters, closer to the equator, such as the Commonwealth of the Northern Marianas (CNMI), Guam, and American Samoa. At these locations fishermen have reported catching these fish deeper than 350 meters (Schroeder pers. com).

The first prototype was delivered in February 2004. A picture of the deployed unit is shown in Figure 3. The system was built on a cylindrical aluminum frame approximately three feet tall and three feet in diameter. Four low light cameras were placed around the diameter of the frame. Two of the cameras had double laser arrays used for sizing purposes. An electronics module housed the system controller, a multiplexer, frame grabber and hard drive. A separate external 12V battery powered the entire system. In the center of the unit was a bait release system that consisted of 2 “seal-a-meal” bags that were cut open by razor blades. The razors were pulled along a track by bungee cords. The timing of the release was controlled by the electronics and triggered by the controlled corrosion of a burn wire. The system used solid spherical trawl floats for flotation and was made negatively buoyant with concrete blocks. Because of the rugose terrain that the unit may be deployed in, an acoustic release mechanism was included to allow the concrete anchors to be cut free if the unit became stuck. The whole system was tethered to the surface by a surface float and line.

Testing began with land based deployments including basic system operations and camera field of view experiments. The first submerged tests were performed in the shallow water tanks at PIFSC’s Kewalo Research Facility. The acoustic release, bait release, cameras and lasers were all tested in a low pressure setting. These tests revealed problems associated with loading the bait, premature razor cuts of the bait bags and failure of the burn wire attachment method.

Testing continued at Makai Pier in Waimanalo in shallow water (10-20 feet) as seen in Figure 4. Full feature deployments were performed using colored water instead of bait. The acoustic release signal was found to work over 100+ feet horizontally. Further, the remote operation of the camera's, lasers, recording and bait release functioned as expected.



Figure 3. Prototype I First Deployment on South Shore of Oahu, HI in approximately 30 feet of seawater (photo by K.Wong)

Fully baited trials were performed off of Honolulu airport's reef runway in 30 to 40 feet of water (see Figure 3). Divers performed field of view tests for both the individual cameras as well as for the system. Problems found included a mechanical failure of the

acoustic release connection, poor bait release characteristics, a small field of view, and difficulty deploying the unit from a relatively small craft. A second day of testing was performed in 25 to 50 meters of water at the fish cages off Ewa, Oahu. Full 500 meter deployments were not performed because of the failure of the acoustic release mechanism (NOAA Diver Depth Limit of 40 meters), however, a “blue water” tethered deployment was performed to approximately 300 meters with no pressure failures.

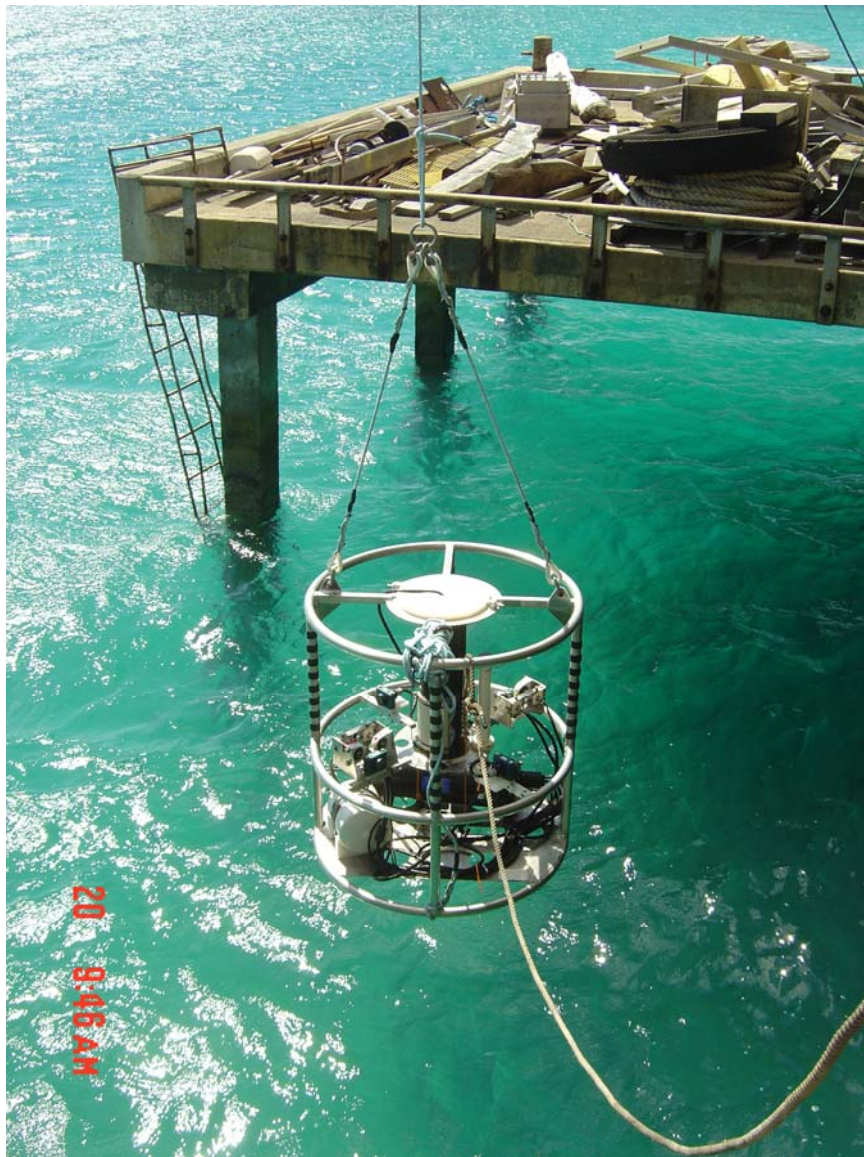

Figure 4. Shallow Water Testing of Prototype I at Makai Pier

The testing was reviewed and a number of the attributes were deemed “out of spec.” (See Wong 2004). Further, evaluation of the captured video by NMFS biologists and other interested parties determined the quality of the video to be too poor to effectively count, identify or size fish or habitat. Finally, as reported by a number of sources (Yoshihara 1997, Gingras et al 1998, Chris Kelley pers. comm, Frank Parrish pers. comm.), the lasers were found to be ineffective instruments for sizing the fish due to the low incidence of fish strikes at the necessary orientation.

A review of the first article revealed a number of competing end user needs from various interested parties. CRED determined that accurate sizing was as important as counts. Also, during this evaluation, several stereo-video systems were reviewed that permitted accurate sizing of a large portion of the field of view, and it was determined by CRED that a stereo-video system should be pursued for Prototype II. Article I specifications were modified (See Wong 2005) and the design and integration were brought in-house.

2.0 PHOTOGRAMMETRY AND VISION METROLOGY SOFTWARE (VMS)

Photogrammetry is defined as the science of measurements of photographs aimed at reconstructing the measurements of two or three dimensional structures from photographic reproductions (Zeller 1952). The principles of photogrammetry date as far back as the 14th century and da Vinci with the development of perspective and projective geometry (Harvey and Shortis 1995). According to Zeller, however, a French military captain, Laussedat, should be considered the originator of photogrammetry. In 1859, Laussedat constructed a camera with known inner orientations and was able to plot parts of Paris using a method called plane table photogrammetry. Many of the problems associated with this method were solved by Pulfrich in 1901 with the development of stereophotogrammetry. Stereophotogrammetry found a niche in the first half of the 20th Century with the development of human flight and the desire for accurate mapping. Today, the majority of literature on the subject is based on aerial photogrammetry for mapping purposes. However, stereophotogrammetry systems are now being used in many industrial, medical and scientific applications. In many close range applications where high precision and accuracy are desired, the stereophotogrammetry principles have been extended to multiple cameras beyond the two required for stereo systems in which precision is proportional to the square root of the number of cameras (or stations) used (Harvey and Shortis 1995).

The fundamental principles of stereophotogrammetry are relatively straight-forward and are based on the same principals that allows humans and other animals with binocular vision to judge depth. The base separation of human eyes is fixed. Therefore, each eye

views an object from a slightly different orientation which creates perspective. This perspective image is then translated in our brains into a relative distance. The same ideas can be applied to images if the relative orientations of the cameras are known. Measurement is then a geometry problem. Figure 5 below is a schematic drawing of this geometry (nomenclature taken from Harvey and Shortis 1995).

Figure 5 is a simplified schematic drawing of the basic stereophotogrammetry principles. Two cameras (C1 and C2) are separated by a known base distance. Any object that lies within the field of view of both cameras can be measured by creating a triangle such as C1-C2-P1 seen on the right side of the figure. If the internal geometry of the cameras is known then the angles to any point in the overlapping space can be found. This information along with the base dimension yields a point in three dimensional space. By finding two points on an object in space, it is a relatively simple geometry problem to find a distance or length.

As with many scientifically derived theories, while the ideas may be relatively straight forward, engineering implementation is a bit more complex. The schematic shown in Figure 6 is an idealized case in which the camera lens is shown to provide a perfect central projection meaning the image point, the perspective center and the object point are collinear. In reality, however, most cameras, particularly off-the-shelf systems, have significant departures from an ideal central projection (Harvey and Shortis 1995) as in Figure 7.

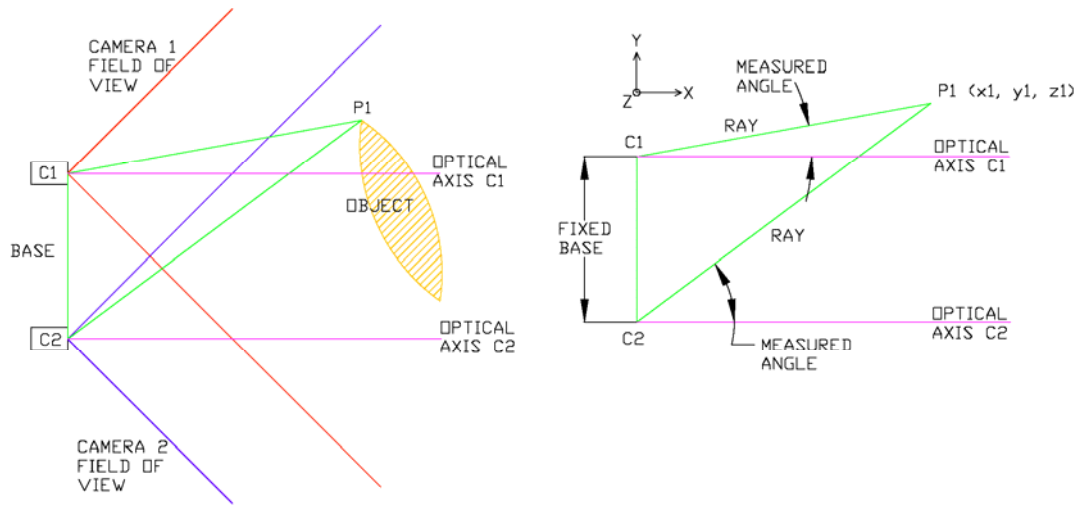

Figure 5. Simplified Schematic of Stereophotogrammetry principles.

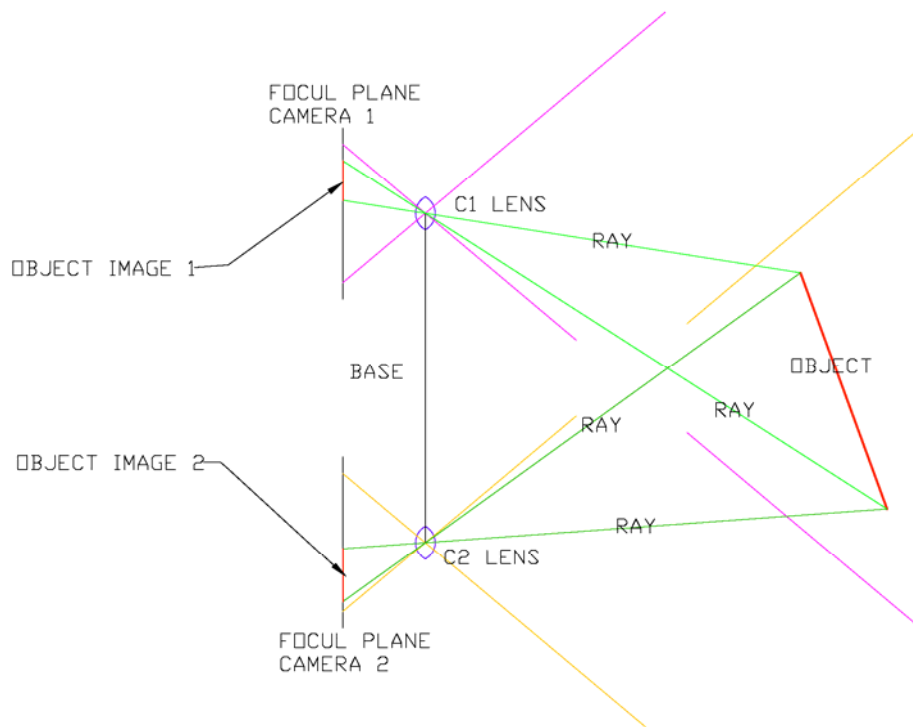

Figure 6. Schematic of idealized case in which the cameras have perfect central projection. (Adapted from Zeller 1952)

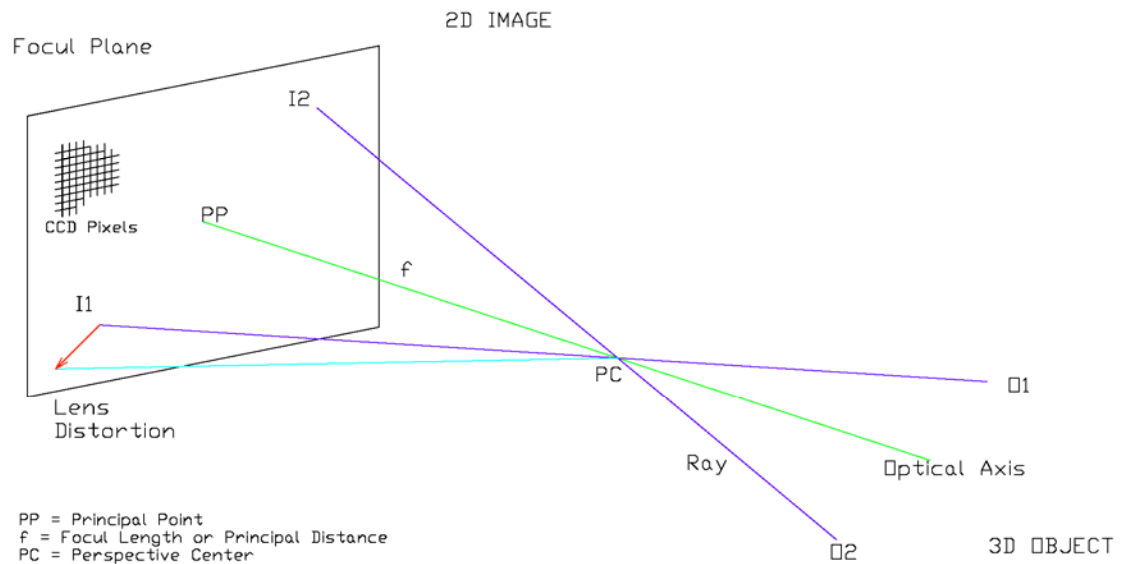

Figure 7. Schematic of a camera with lens distortion. (Adapted from Harvey and Shortis 1995)

Traditionally, photographs from stereophotogrammetry were analyzed by mechanical means such as stereocomparators which enable the photographs to be digitized. The development of computers has allowed this process to become far more accurate and robust. As previously mentioned, many high precision stereophotogrammetry systems are in use today in industrial, medical and scientific fields. One of these systems is called Vision Metrology System (VMS) from a company called Geomsoft. This system was developed by Mark Shortis and Stuart Robson. Shortis and Robson have been collaborating with Dr. Euan Harvey, an ecologist at the University of Western Australia to develop the VMS software and optimize it for use in underwater applications in order to improve the precision and accuracy associated with underwater visual surveys. Figure 8 is an example of the VMS-PC interface.

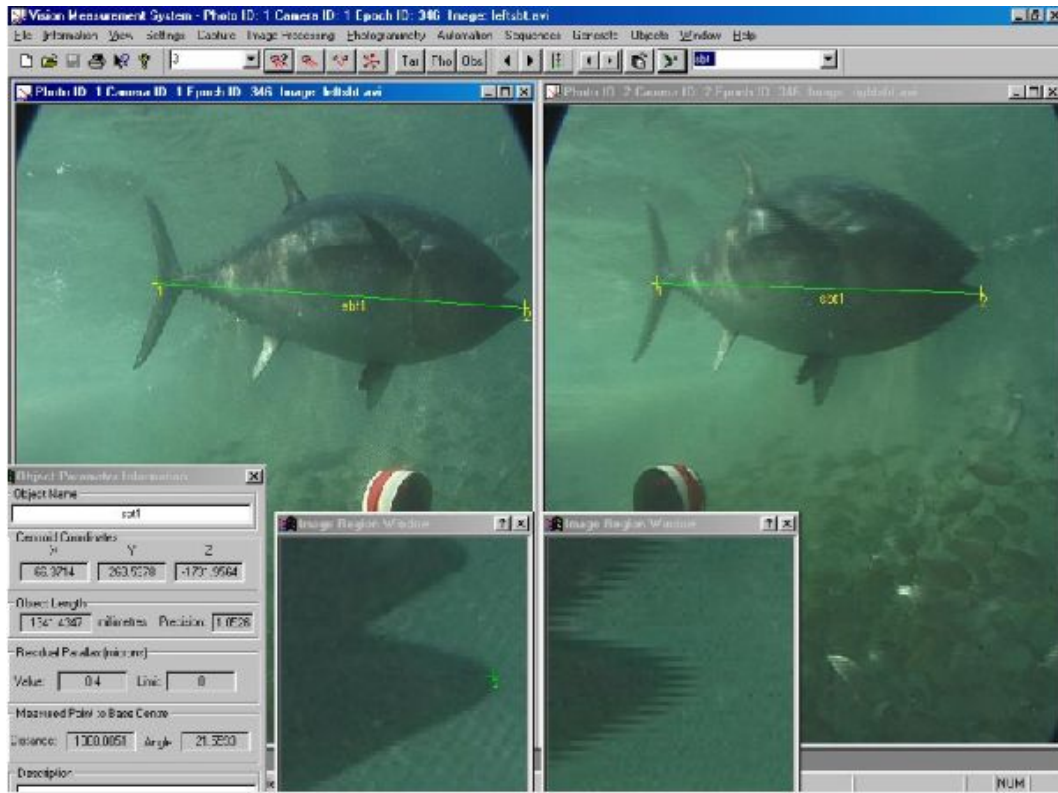

Figure 8. VMS Software Interface

In order to account for the imperfections associated with real cameras and lenses and to determine the relative orientations of the stereo pair of cameras, VMS requires a calibration process. This process is described in many of the papers by Harvey, Shortis and Robson (e.g Harvey and Shortis 1995) as well as on the Geomsoft website (www.Ggeomsoft.com). The first part of the calibration is used to define the internal geometric characteristics of the cameras (camera calibration). Characteristics include the principal distance (or focal length), the principal point (intersection of the optical axis of the lens with the focal plane), the lens distortion and biases in the spacing of the pixels on the CCD (charge-coupled device) sensor (see Figure 7). The second part of the calibration defines the relative orientation of the two (or more) cameras with respect to

one another. This process yields the separation of the perspective centers of the lenses, the angles of the optical axes and the rotations of the CCD sensors (i.e. the pitch, roll, yaw and base separation of the cameras relative to one another). This process is made easier with a purpose built frame that has clearly visible white dots separated by known distances relative to one another.

Harvey and Shortis have published a number of papers dealing with the precision, accuracy and stability of stereo-video systems using the VMS software and calibration process described above. One of the most recent (Harvey et al 2003), involved the measurement of caged southern bluefin tuna (see figure 8). This experiment was highly beneficial as it allowed the wild caught tuna to be measured *in situ* and then captured for accurate measurements using calipers. The tuna lengths varied from 830mm to 1412mm and widths ranged from 228mm to 365mm. Four statistical measures were incorporated and results from length and body width are shown in Table 1.

This study concluded a number of other important factors as well. First, several calibrations were done in both fresh water pools and in salt water in order to measure the stability of the system. Results showed a very stable system, particularly with regards to distance measurements which are of primary interest to biologists. These calibrations also found only a 0.07% change in magnitude when calibrating in fresh water as opposed to salt water. Second, it was found that taking multiple measurements of the same fish in sequence and averaging helped to minimize the effects of swimming motions on measurements. Further, they found that the error bars associated with this inherent error

would begin to level off after 5 measurements. A final important finding from previous studies (e.g. Harvey and Shortis 1999), was that fish could be accurately sized at orientations up to 50 degrees to the camera. Problems arise at larger angles because in general, a clearly defined point is no longer visible in at least one of the images.

Table 1. Errors associated with stereo-video estimates of length and width measurements of southern bluefin tuna. (Adapted from Harvey et al 2003)

	E (mm)	AE (mm)	RE (%)	RAE (%)
Length (Sample Size 54)				
Mean	1.72	6.06	0.16	0.56
1 S.D.	8.13	5.62	0.76	0.54
1 S.E.	1.11	0.77	0.10	0.07
Width (Sample Size 47)				
Mean	1.37	3.93	0.51	1.37
1 S.D.	5.06	3.43	1.78	1.24
1 S.E.	0.74	0.50	0.26	0.18

O defined as observed measure

T defined as caliper measure

Error $E = O - T$
 Relative Error $RE = E / T$
 Absolute Error $AE = |E|$
 Relative Abs. Error $RAE = |RE|$

The design of the stereo-video system is largely defined by the base separation of the cameras. The ideal base separation for the stereo camera's is based on the "Theory of Errors in Stereophotogrammetry." A detailed explanation of this theory is beyond the scope of this review, however, it is presented in Zeller 1952. Based on this theory, it was determined that the ideal base separation to distance of desired measurement should lie between 1:4 and 1:20, meaning that for a 1 meter base separation, the best measurements would be made between 4 meters and 20 meters from the midpoint of the base separation

(Zeller 1952). By converging or “toeing in” the stereo cameras, this ideal base separation to distance ratio can be varied as well (see Figure 9). Therefore, a base separation should be implemented for each particular application. For example, stereophotogrammetry of wildlife, separation would be based on the expected size of the flora or fauna, expected range, and expected field of view. Charts and computer scripts are available to optimize the base design. Figure 9 shows an example of a stereo system with a base separation of 36 inches. By turning the cameras inward 10 degrees, the start of the measureable field of view moves from 18 inches to 12.6 inches. This means that larger objects can be measured closer to the system. It also provides for a wider overall field of view.

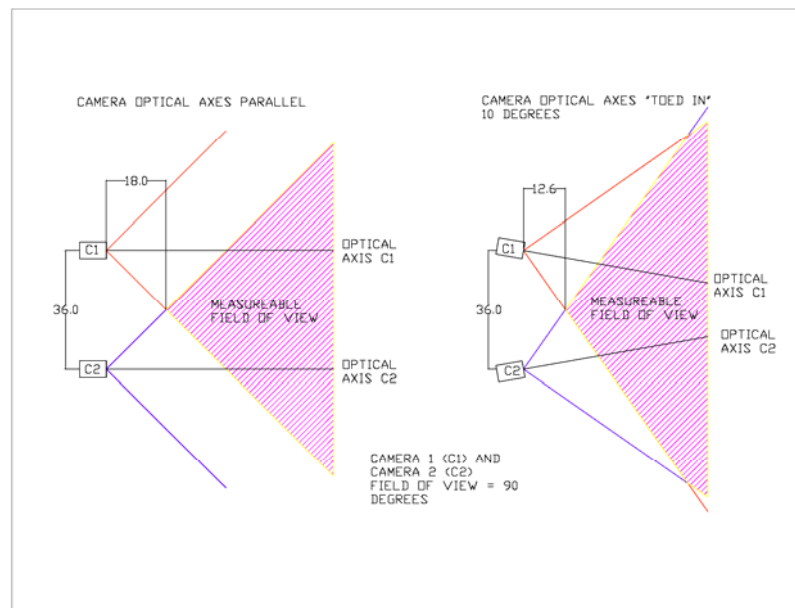

Figure 9. Example showing the different fields of view resulting from “toeing in” the stereo cameras.

3.0 PROTOTYPE II

A second prototype meeting the specifications found in Wong 2005 was designed, built and tested. The primary goal of the second prototype was to develop a stereo-video bait station that could incorporate the previously described Vision Metrology Software (VMS) while still allowing for high resolution images at depths to 350 meters. The tested unit is shown below in Figure 10. A schematic of the deployed system is shown in Figure 11. The design, selection and testing of the subsystems of prototype II is described below. A conscious effort was made to compartmentalize each sub-system in order to easily allow for replacement of broken parts and to allow the system to be updated on a part-by-part basis as technology improves.

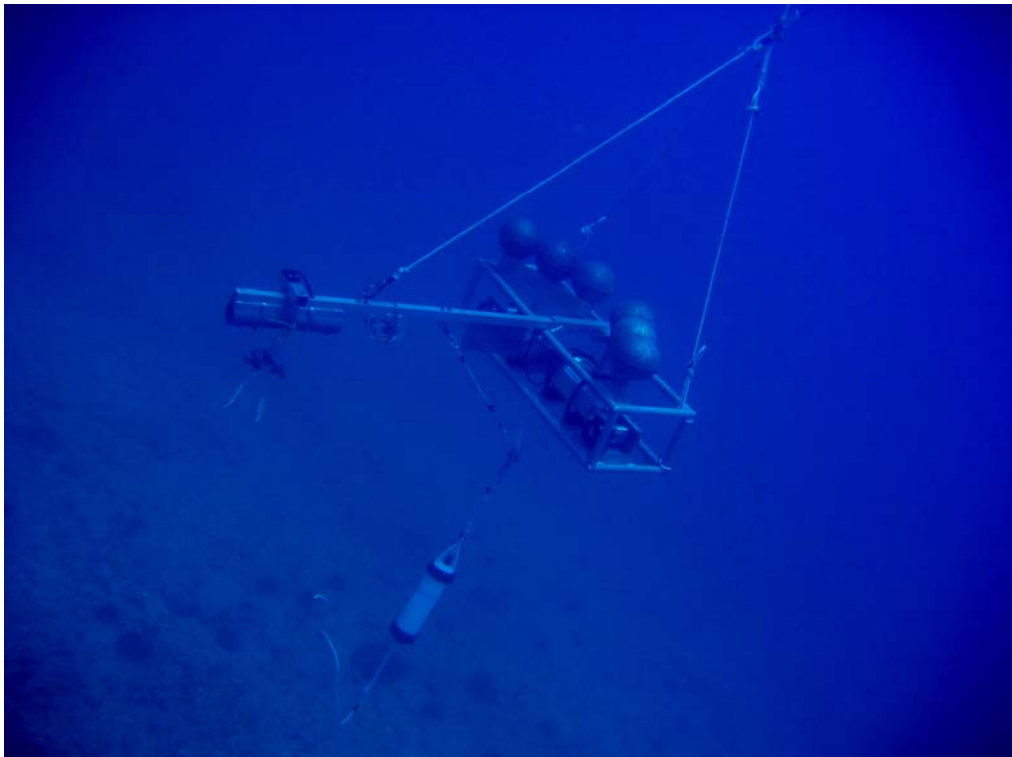

Figure 10. Prototype II as tested with second acoustic release.

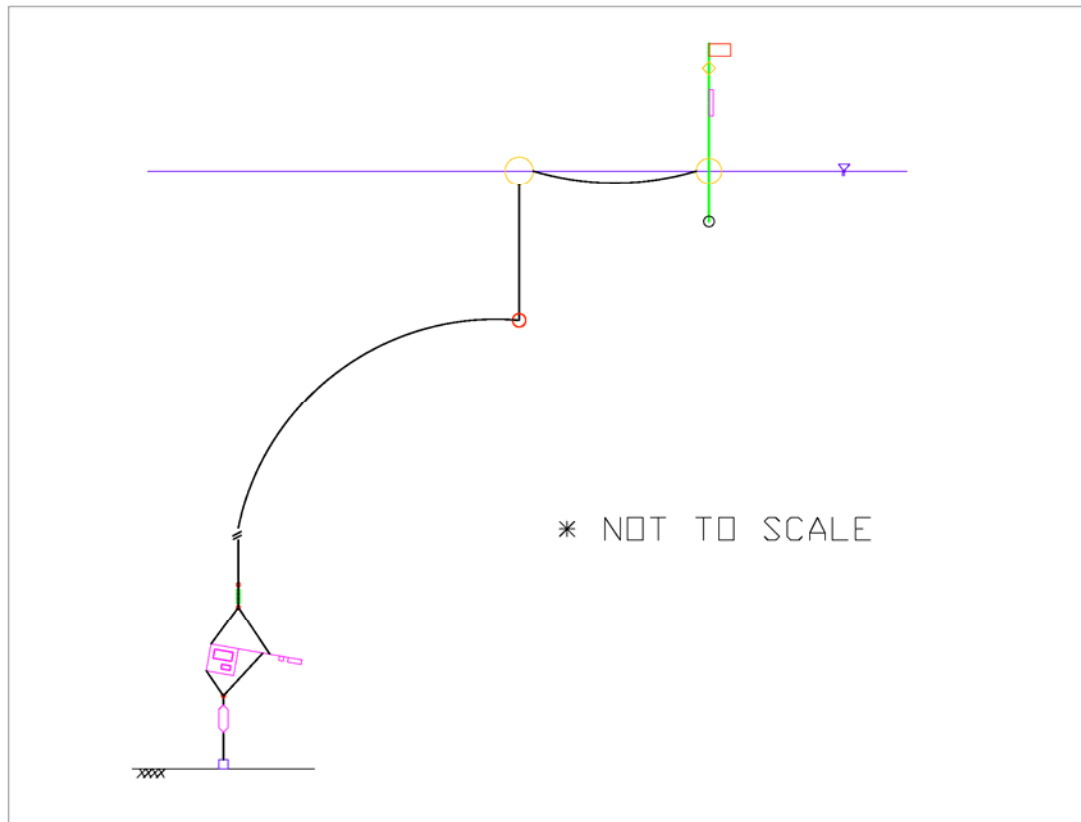

Figure 11. Schematic of the deployed BotCam with the BotCam shown on the bottom left, the surface signature at the top right, connected by the surface line.

3.1 Video Capture Electronics

The primary component and stumbling block to the development of this camera bait station was the video capture device. The prototype I design from SOSI used a system designed for video security systems. The system used a multiplexer that allowed all four video images to be displayed at the same time, or to rotate through the four frames in a pre-programmed manner. The resolution was fixed, however, and only one video stream was recorded. The system input composite video and converted this stream to a digital format to be stored to a hard drive. This whole system was housed in a custom-built aluminum pressure housing. The combination of this video capture system with the

cameras provided with the prototype I design proved to be too poor of quality for our biologists needs.

Therefore, the primary factor driving the design of prototype II was to provide high resolution images using low light cameras. Previous work done by HURL's Pisces submersibles, proved the Remote Ocean Systems (ROS) Navigator camera had the capability of providing video that would be of acceptable quality for fish identification, therefore, this camera was chosen as the baseline for comparison. Also, the VMS software required a digital file.

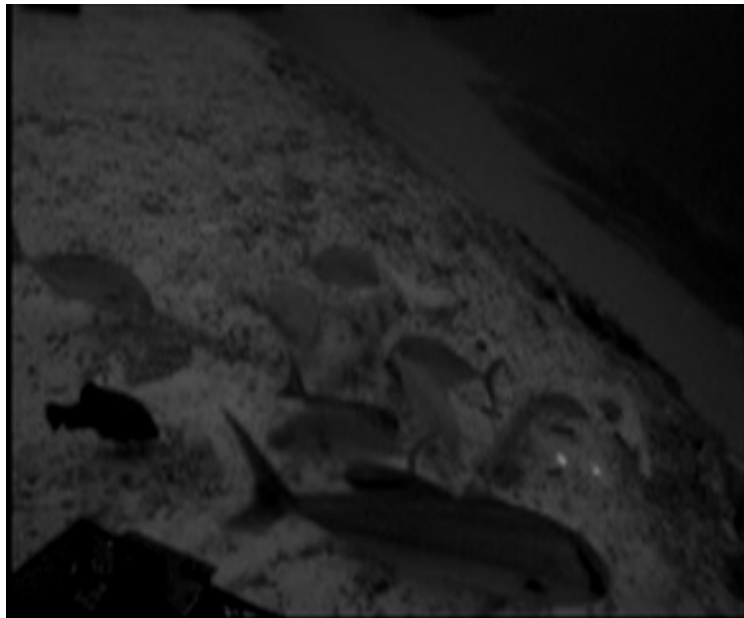

Figure 12. Frame grab from HURL bait station using ROS Navigator camera.

Several camera options were explored. This review showed that although fully digital cameras would provide several advantages in image quality, they are not readily available in ultra low-light sensitivity models. Further, custom housings would have to be

designed for virtually all of these types of cameras. Therefore, a solution was sought that would allow for a composite video input and a digital output.

The HURL submersibles use a simple digital video (DV) recorder to capture video from their ROS Navigator cameras. While these off-the-shelf consumer units provide high quality video and are relatively inexpensive, they pose many problems. First, they require an operator to turn them on and off, to start and stop recording, etc. Second, although they record in a digital format, they record to a tape. In order to process this video with the VMS software, the video would have to be transferred from the tape to some alternative digital format that could be read as an .avi file. Further, although several of these products have relatively small footprints, they are all built around a rectangular form factor. Pressure housings rated to our required 500 meter minimum depth would require either a cylindrical or spherical housing. Fitting these two shapes together leads to unnecessarily large housings. Other proposed designs along the same lines such as using off-the-shelf camcorders or digital video recorders (DVR's) met with the same problems.

An alternative idea was to design a custom computer system based on a PC104 or alternative motherboard. PC104's were originally designed for small, rugged applications such as this one. A PC104 system was recently incorporated into the NOAA Fisheries Autonomous Underwater Vehicle (AUV) using LabView software to control the system. Several vendors and products were identified. High resolution video cards were available that would allow the input of a composite video stream, conversion to a

digital format, and finally recording to a hard drive or flash memory, solving many of the problems associated with the off-the-shelf solutions. Further, integrated control systems were investigated that could be incorporated into the PC104 platform to deal with the autonomous requirements needed. These systems could then be put into a custom depth housing.

In the process of shopping for custom electronics packages and housings, a company was found in British Columbia, Canada, called Deep Development, which was in the process of developing a product that would meet our needs. Deep Development is a subsidiary of Gatekeeper Systems that specializes in video recording devices for applications such as school buses. Deep Development was spun-off to specialize in rugged applications and their standard products allow for composite video input, digital video storage, multiple camera inputs, high resolution images, as well as external triggers.

In December, 2004, Deep Development delivered one of their existing products called the Viperfish Land. Based on an evaluation of this product, both CRED and Deep Development felt that this system could be quickly modified into a new product, the Viperfish Deep, which would suit our needs. A prototype Deep unit was delivered in February 2005. In order to accomplish the bait release needs and automated features required, a separate industrial timer and battery was included its own housing. This new system was thoroughly tested (see testing section) with all the other components and evaluated by CRED engineers and scientists. Based on this evaluation, a custom unit was ordered.



Figure 13. Viperfish Deep Unit from Deep Development Corporation

3.2 Cameras

After completion of testing and a thorough evaluation of prototype I, it was abundantly clear that image quality would have to be improved in order to allow for species and habitat identification, fish sizing and accurate counting. It was still unknown, however, if the lack of resolution from prototype I was due to the video capture electronics, the camera's, or most likely, some combination of the two. The cameras provided by SOSI were designed and built in-house and had the advantages of being compact and relatively inexpensive. However, the image quality they were able to provide was highly suspect, therefore, several cameras were tested. A first comparison of camera specifications is shown in Appendix 2.

All of the candidate cameras use a charge-coupled device (CCD) sensor. These CCD sensors consist of a special silicon wafers with thousands of photoelectric pixels evenly

spaced around the wafer. When the shutter of a camera is open, individual pixels collect photons of light. The number of photons on each pixel is then translated into a light intensity. This collection of light intensities is then combined to form an image. In recent years, very high resolution, low light sensitivity CCD cameras have become available that compete with silicon intensified tungsten (SIT) sensors at a fraction of the cost.

Seven cameras were tested to various degrees with two video capture devices, the Viperfish Deep and an off-the-shelf Sony PC120 digital handycam that is used by CRED for numerous applications. Five of the cameras were monochrome and two were color. Monochrome cameras have higher resolution than similar quality color cameras and all but blue color is filtered out at the target depths. Specific test results are reported in Appendix 3. Based on in air resolution and low light testing using both recording systems as well as shallow water tests using only the Viperfish Deep, three cameras were chosen for side-by-side comparison on full depth deployments. These cameras were the ROS Navigator (ROS), the Deep Sea Power and Light 5000 (DSPL 5000) and a custom made camera using a Watec lens designed by Scott McEntire from the Northwest Fisheries Science Center.

Side-by-side testing of the DSPL 5000 and the Watec with the ROS was performed at the the opakapaka nursery grounds found by Parrish (~ 75 meters) and at a deeper bottomfish site, the Sampan Pinnacle (~250 meters) located inside the Division of Land and Natural Resources (DLNR) restricted fishing area (RFA) 5 which is closed to bottom fishing.

Both of these sites are outside Kaneohe Bay, Oahu, Hawaii (see Figures 30 and 38). The DSPL camera performed well at the shallow nursery ground depth, but images collected at the Sampan Pinnacle were deemed poor. The Watec camera performed better at the Sampan Pinnacle than at the shallower nursery ground. This is likely due to an overcompensation of the light intensity at the shallow depth. While the Watec camera resolution was not considered as good as the ROS, it was promising. Scott McEntire reported that he is able to make these cameras for less than \$1,000 each. However, because it was a custom design and not readily available, and due to its limited range of application, it was decided to use the ROS Navigator for the prototype II and III designs.

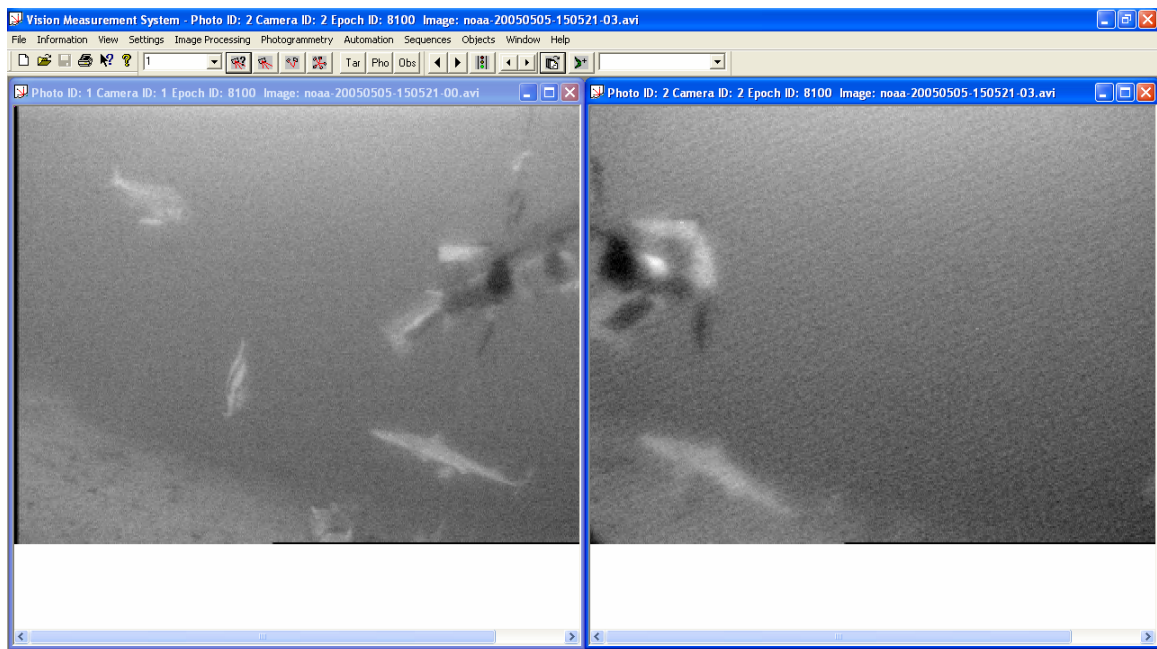

Figure 14. Frame grab of VMS software from the Sampan Pinnacle test site. Synchronized Images with ROS Navigator left frame and DSPL 5000 right frame. Depth was approximately 250 meters.

3.3 Frame Design

As noted previously, the prototype I frame was based on a cylindrical design with all the components contained within this frame. Given the harsh nature the ocean environment

as well as limited ship space, this relatively compact design had many advantages. However, a couple of problems were associated with this type of design. First, there is a desire by the biologists to see the bait. This is difficult to accomplish with a compact design without blocking much of the field of view. In fact, most of the camera bait stations employed currently and in the past have incorporated a bait arm. Second, the photogrammetric process requires that the two independent video streams of the stereo-pair be synchronized in time frame-to-frame. Lack of synchronization of the video will result in increased errors in the measurements. High end stereo-video systems are capable of hardware synchronization. This, however, is not a simple task and would not be readily implemented into the Viperfish Deep unit. A relatively simple method, however, is employed by Dr. Euan Harvey and others in Australia. A device is placed within the field of view of the stereo-pair that flashes diodes at a high frequency comparable to that of the recording frame rate. By viewing the video, the two images can then be manually synchronized by matching video frames that show the same diode lit. This method has the added advantage of being an independent synchronization method.

A second issue involved the number of cameras that should be incorporated, the field of view needed, and the direction that the cameras should point. The first prototype incorporated four cameras that could be independently rotated to point in many directions. Placing them in a outward looking orientation allowed for viewing in all directions and had a horizontal coverage of about 280 degrees. One of the problems associated with bait stations is how to deal with fish that move in and out of the field of view, so having a large field of view helps to solve this problem. However, given the

high cost of cameras chosen, the limited camera inputs associated with the video capture device, and the post processing time associated with video, CRED decided it was better to solve the stereo-video problem as simply as possible and to only use a stereo-pair for the second prototype with the understanding that the cameras could then easily be turned in different directions if stereo-video did not end up suiting user needs. The orientation of the cameras was also an important question. Two groups are currently using camera bait stations on a relatively large scale. The Australian Institute of Marine Science (AIMS) and Dr. Euan Harvey at the University of Western Australia developed a horizontally viewing system. The New Zealand group of Willis and Babcock, on the other hand, are using a downward looking system (see figure 15). Both of these systems have inherent advantages and disadvantages, however, the downward looking systems have two primary disadvantages. First, where large schools of fish are active, the field of view can quickly become saturated with fish leading to overly conservative counts at high levels (see Figure 15). This is also a problem associated with horizontal viewing systems, however, in general, they don't suffer as badly. A more important problem reported with downward looking systems is the lack of contrast between many fish species and the bottom making them hard to see and identify. Several fisheries scientists at the NMFS Video Workshop (Somerton and Gledhill 2005) cautioned against using this approach but did recommend that a skewed downward view may provide for spatial coverage while still providing for the necessary contrast between fish and the background.

Based on this information, a horizontal viewing bait arm solution was sought. Several designs were proposed and five concepts (see Appendix 1) were submitted to various interested parties at PIFSC and HURL. Figure 16 is an example.



Figure 15. Left image horizontal looking bait station (courtesy of Harvey). Right Image downward looking bait station (courtesy of Timothy Langlois).

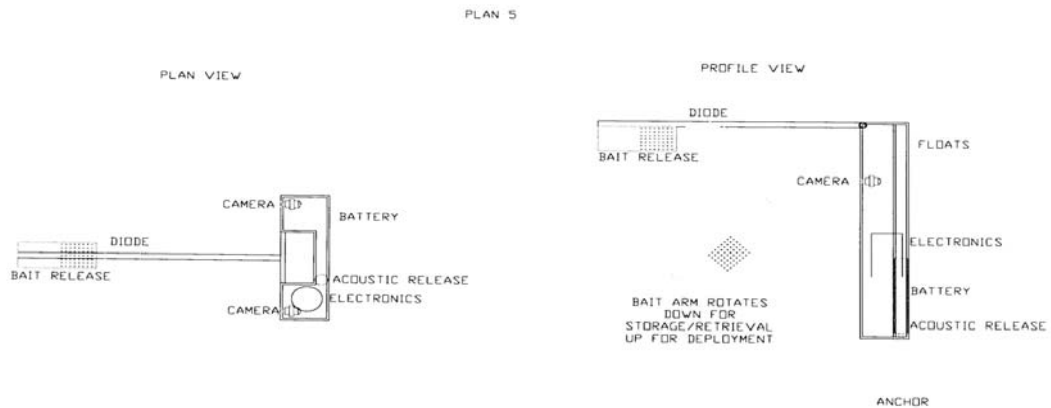

Figure 16. BotCam Prototype II Stereo-Video Concept (Folding Arm)

Several issues were considered:

- Bait and stereo-video sync device visible by both cameras

- Compact, light weight and rigid design
- Minimum camera separation of ~ 30 inches
- Minimize potential snagging from lines and cables
- Ability to incorporate both acoustic and galvanic release
- Ability to be deployed in high rugosity, steep slope environments and still be recovered with minimal risk of damage to equipment and benthic habitat.
- Incorporate two cameras, video capture electronics, bait release system, stereo-video sync device, and other oceanographic instruments such as temperature and pressure sensors.
- Ability to deploy and recover system from a variety of vessels that may not have mechanical means of lifting such as cranes, A-frames, booms and pinch-pullers.

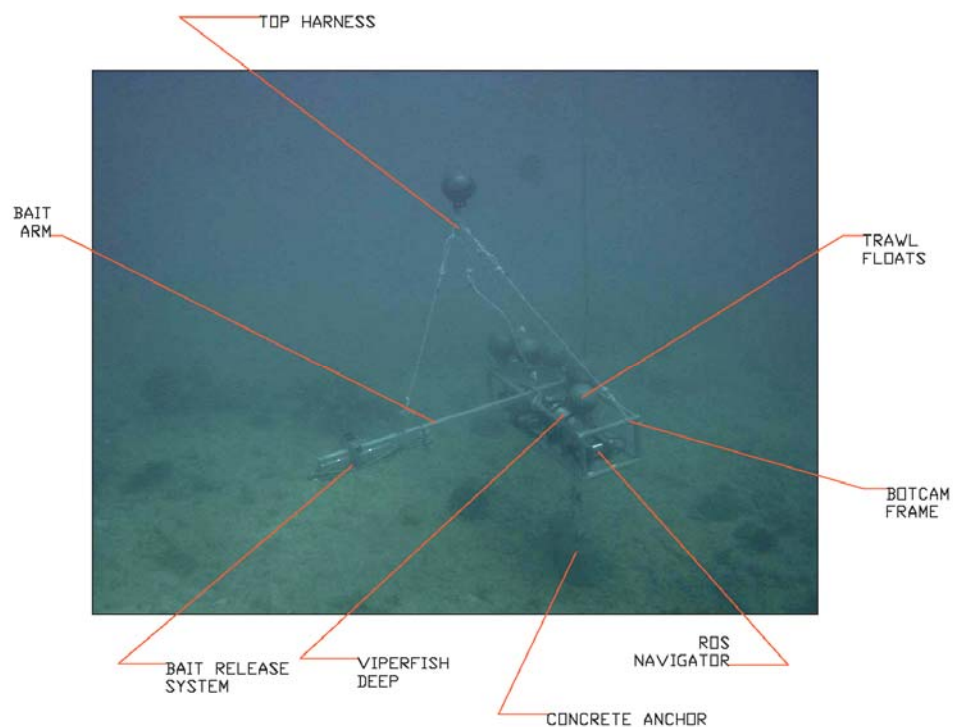

Figure 17. BotCam Prototype II. Front Isometric View. Photographed in approximately 15 meters of water, South Shore, Oahu, HI.

Figures 17 and 18 show the final design. This design features a rigid platform that allows the relative camera orientations to be maintained. This is critical for the stability of the stereophotogrammetry calibration. This design was also chosen for its relative simplicity, lack of moving parts, easy breakdown of the bait arm and comparability to other camera bait stations which have all ready been proven.

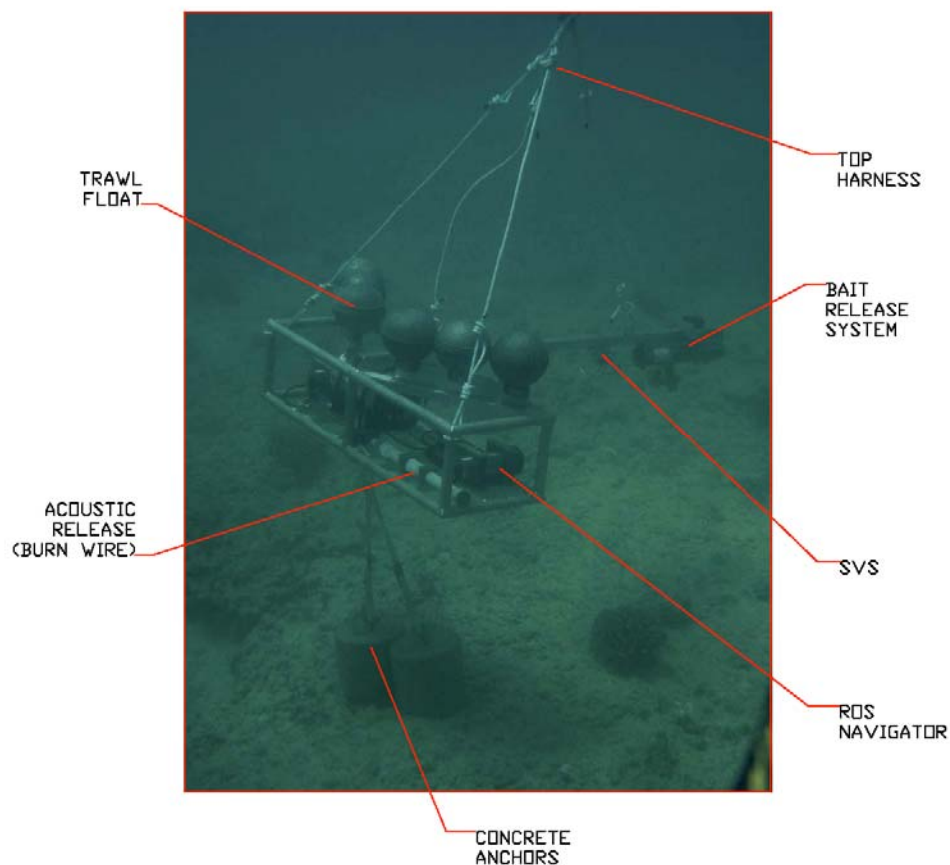

Figure 18. BotCam Prototype II. Back Isometric View. Photographed in approximately 15 meters of water, South Shore, Oahu, HI.

Because the first prototype unit produced by SOSI failed to produce images of target species at target depths, this was the primary goal of the second prototype. As a cost

saving measure, many of the components from prototype I were used including the acoustic release produced by Subsea Sonics (www.subseasonics.com). The release was an AR-50 burn wire system. An acoustic signal sent from a surface transducer triggers this unit to corrode a wire thereby releasing the load attached. Although the system designed by SOSI failed, a new hardware solution provided a reasonably robust solution to allow for full target depth drops. This solution, however, largely drove the design of the bait station frame. The final design was chosen because it was considered the most simple and compact option. The design also allowed for the station to easily self-orient down current. A similar anchoring system to prototype I was chosen for its simplicity and wide range of application to various terrain. The flotation, however, was rigidly incorporated to the frame. Freely tethered mooring balls made for difficult deployments and recoveries and they added to potential snagging hazards.

3.4 Acoustic Release

As noted above, the acoustic release from prototype I was incorporated into the design of prototype II. The AR-50 units from Subsea Sonics offered a couple of advantages over other more traditional acoustic release systems. First and foremost, they are inexpensive relative to other acoustic release systems with similar depth ratings. Second, they are solid state devices with no mechanical motions necessary to trigger the release. An 80 pound test sacrificial burn wire was chosen. The SOSI design seen in Figure 19 relied on a lever arm to remove some of the load from the wire itself, however, during prototype I testing, this proved to be insufficient and caused the burn wire to break prematurely.



Figure 19. Prototype I Acoustic Release Anchor Point. The lever arm was designed to decrease the load on the burn wire.

The design used for prototype II shown in Figure 20 completely removed the anchor and buoyancy load from the burn wire and limited the load to that of a bungee cord. This design proved to be effective and we did not experience any failures after initial adjustments. However, the design did limit the amount of buoyancy that could be used and the unit had to be adjusted to just barely positive without the anchors attached. Increasing buoyancy caused the friction between the pin and the hole it was designed to slide through to increase to the point where the pin would not slide free when the burn wire was corroded. This meant that when released from depths of 250 meters, it took approximately 20 minutes to reach the surface. Further, there was a concern with the manufacturers' ability to provide the volume of burn wires needed for multiple unit as well as the cost associated with using sacrificial parts. Therefore, midway through the testing of prototype II, the acoustic release shown in Figures 21 and 22 was identified, selected among several alternatives, and incorporated into the design.

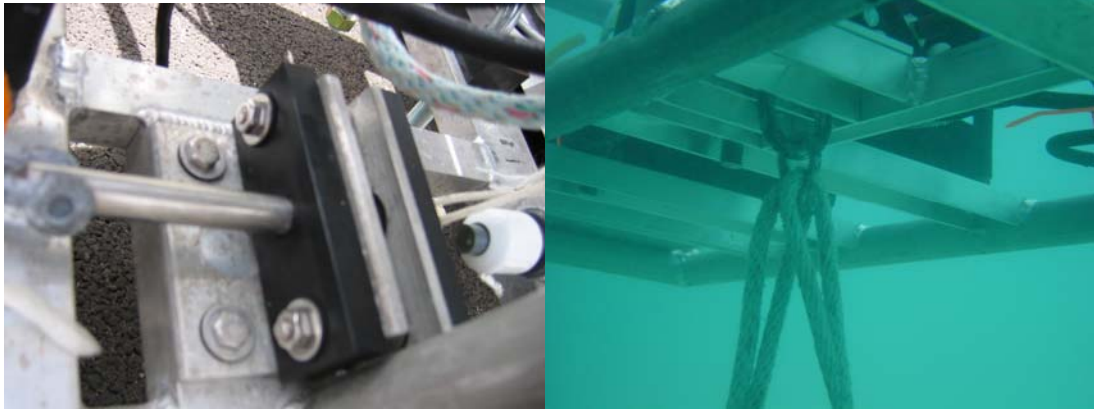

Figure 20. Prototype II Acoustic Release Anchor Point. The left image shows the pin and burn wire. The right image shows the anchor line and attachment point.



Figure 21. IXSEA Acoustic Release

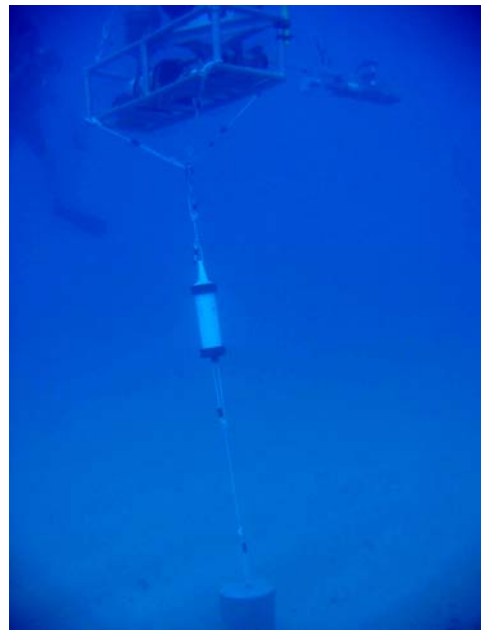

Figure 22. IXSEA Acoustic Release

3.5 Bait Release System

The delayed and autonomous design specification for this camera bait station required a bait release system that would allow the bait to be isolated from the environment until the cameras and recording process were started, at which point the bait was to be exposed.

The large majority of previous baited camera systems have been used in near real-time applications, therefore, bait in some form was simply attached to the end of a bait arm and sent to the bottom in an exposed state. The HURL bait stations used a large seal-a-meal type bag with ground bait (generally squid and opelu). These bags were then ripped open with the submersibles robotic arms (see Figure 23).

SOSI used a similar seal-a-meal bag approach on prototype I. However, using the same type of bait mixture as HURL, Kelley and others felt that the bait was not being distributed well enough (see figure 24). Kelley requested a system for prototype II that would dump all of the bait on to the bottom, better simulating the approach taking during submersible bait stations.



Figure 23. Frame grab from HURL bait station video showing the robotic arms ripping open a bait bag. The fish are Hawaiian Grouper.



Figure 24. Bait bag from Prototype I. Bait was not well distributed into water column.

Several concepts were considered for this system. Ideas included the use of a compressed gas or a mechanical means to expose the ground bait. Experience gained from the use of the burn wires used on prototype I, however, showed this technology to be a simple and reliable method for remote triggering. Further, the autonomous nature of the bait release was not the focus of this prototype, so the simplest and most cost effective solution was sought. This turned out to be a Niskin bottle run in reverse. Small (i.e. 1.7 liter) Niskin bottles are relatively light weight, compact, provide an adequate seal, and are cheap and readily available. When filled with liquid, the incompressible nature of water means the plastic bottles no longer act as a pressure vessel. Further, elastic cord such as surgical tubing is readily available, inexpensive, and works well at depth as a spring mechanism to pull off the caps of the Niskin bottle. (See Figure 25).

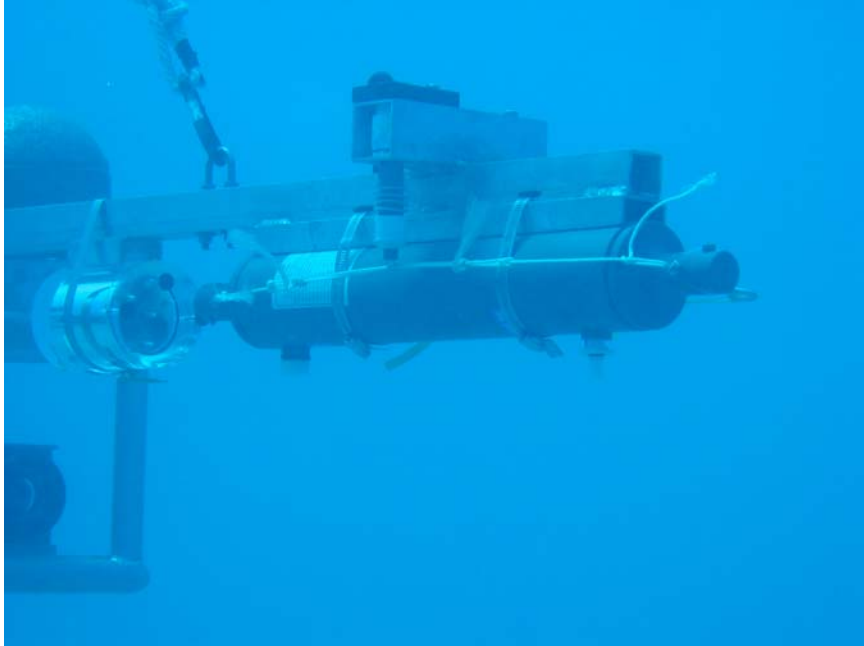

Figure 25. Bait Release System consisting of a 1.7 liter Niskin bottle run in reverse. The caps are held in place until the burn wire, shown in the middle of the photo, is corroded away. Surgical tubing attached on the other side of the bottle pulls the caps off exposing the bait to the environment. This process is controlled by a signal sent from the Viperfish Deep electronics unit.

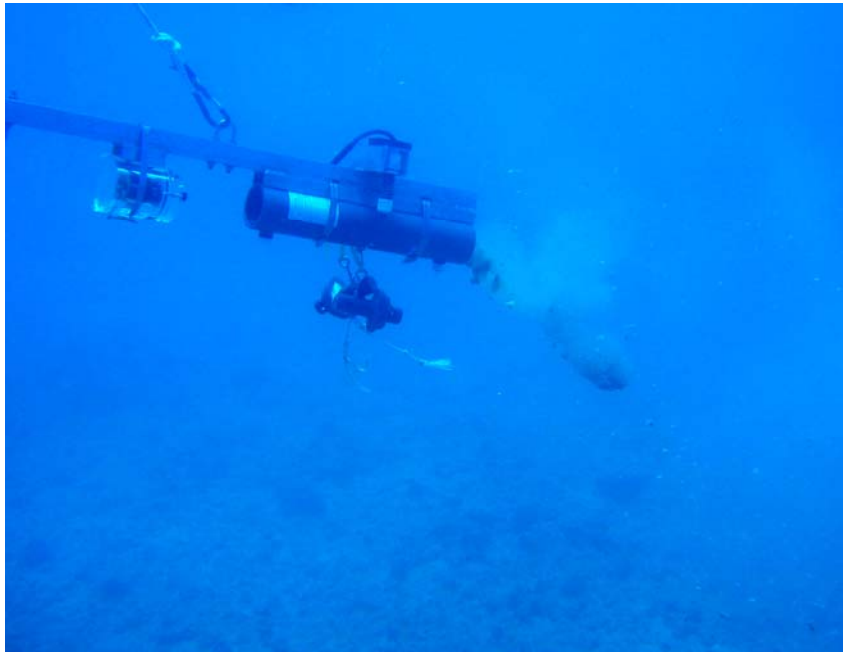

Figure 26. Bait release. The burn wire has eroded and the caps have been pulled off the bottle. Bait can be seen flushing out of the container. The bait arm is designed to point down-current, therefore the bait should remain visible in the cameras.

The system is fairly simple to operate and the bait arm can be quickly and easily loaded for deployment. A detailed description of the bait loading process can be found in Appendix 10. The bait is loaded and the burn wire is attached to the auxiliary bottle. When the Viperfish Deep unit boots and begins recording, a signal is sent to the burn wire to supply the necessary power to corrode the wire. When the burn wire is sufficiently weak from the corrosion process, the surgical tubing provides enough force to pull the lids off both sides of the Niskin bottle and the bait is then flushed out. The slight downward angle of the bait arm helps with this flushing process. (See Figure 26). The bait is ground in such a fashion as to provide both a liquid that disseminates with the bulk flow to attract fish as well as small chunks that settle to the bottom downstream of the cameras to keep fish in the area. Kelley has found that if the fish are rewarded with a meal, they are more likely to stay in the vicinity. However, if a large piece of fish or squid is used, a single fish will tend to take the bait and swim away.

3.6 Stereo Sync Sync Device (SVS)

Stereophotogrammetry of moving targets requires that the images used for a measurement be synchronized in time. High-end industrial stereophotogrammetry systems accomplish this synchronization using hardware solutions. These are complex systems and are inherently expensive. A simple solution suggested by Harvey and Shortis (Harvey and Shortis 1995) employs a device that turns on and off light emitting diodes (LED) at a frequency similar to the frame rate recorded by the video camera's. This sequence of lights is programmed to fire on a regular basis. By synchronizing the

LED's in both the left and right images of a given frame, the images can be matched in time down to a single frame. This method has the added benefit of being an independent check of synchronization and can be used to periodically test for drift in the video which is especially problematic in tape recorded systems.

Harvey generously loaned CRED one of his units as an example. His unit, however, was only rated to a couple hundred feet and at a minimum, the housing would have to be redesigned for our application. Further, the unit did not include any kind of delay, therefore, the unit would have to run continuously for the entire deployment of the system which could last as long as 48 hours. This would cause an increased drain on the batteries.



Figure 27. SVS. Left image is an isometric view of the housing. Right image shows the face of the SVS with the diode pattern. The SVS is mounted on the bait arm in such a way as to allow these diodes to be seen in both cameras. The diodes are programmed to fire at a frequency of 30 hz to match the video frame rate on a regular interval.

Specifications were drawn up by CRED engineers for this product. A quote from Sexton Photographics LLC was chosen and the final product is shown in Figure 27. This compact unit uses three standard D-cell alkaline batteries. Various setting controlling parameters such as LED brightness, time between sequences, length of sequences,

frequency of LED lighting and power delays are available by setting dip switches on the face of the custom built circuit board. A simple magnetic switch is used to turn the unit on and off.

3.7 Pressure Sensor

Although not considered a critical part of the design, a pressure sensor allows for an accurate record of the actual depth of deployment of the BotCam. Depth soundings from a ships electronics offer a good idea of the deployed depth, but because of the high slope environments that will likely be encountered, it will be difficult to get an accurate shipboard reading.

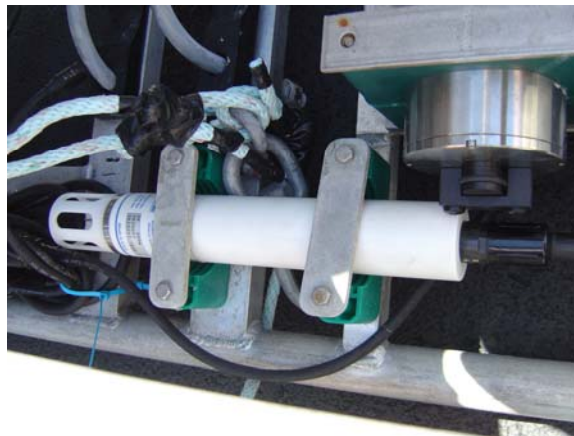

Figure 28. Photo of Seabird 39 Temperature and Pressure Recorder attached to Prototype II BotCam.

Multiple systems were evaluated, however, a Seabird 39 pressure and temperature recorder was chosen. Seabird products are considered by many to be the industry standard. CRED uses many of these products and personnel are familiar with their operation. The products have also proven to be rugged, reliable and compact. Further, adding a temperature record, a fundamental water quality parameter, was an additional

benefit. The temperature and pressure sensor is completely independent of all other sub-systems on the BotCam and can therefore be easily upgraded, changed, fixed or removed without affecting the rest of the system. (see Figure 28)

3.8 Surface Signature

The high cost of the BotCam components in combination with the relatively deep target depths (beyond conventional diving depths), steep slopes, and high rugosity terrain expected, has led CRED engineers to include two methods for recovery of the BotCam. In order to minimize damage to both the benthic substrate and to the BotCam itself, the standard recovery method is expected to involve dropping sacrificial weights using the aforementioned acoustic release. However, acoustic releases are notoriously fickle. Therefore, a line will be used that will run from the BotCam to the surface. This line will allow the entire package to be recovered including the weights.

The surface line has many other benefits as well. First, during deployments, it allows for a controlled fall. This makes it possible to ensure that the BotCam actually reaches the bottom at a depth and location of interest. Most bottomfish habitat is found in high flow, steep slope areas. If a unit were simply dropped over the side of a vessel, it is highly likely that it may drift to a depth deeper than it is rated for and the entire unit would be lost. Further, the controlled fall will allow for a much more accurate GPS mark of the drop location.

The surface line also allows for a surface signature. A “High Flyer” similar to those used by long line fishing vessels is used. This high flyer consists of a 18 foot aluminum pole. Counterweights are added to one end of the pole to keep the unit upright. An inflatable orange buoy keeps the unit afloat. On the pole, a radar reflector, a flag, and a combination strobe light and radio beacon unit are attached. The strobe light/radio beacon is a product from Seimac. The radio beacon uses a VHF frequency and the tracking unit uses both audio and visual signals to show direction and signal strength. These will all help to locate the unit upon return to a site or in the case that the unit drags or floats free from the bottom. It will also serve to help vessels avoid potential interference with the surface line in high traffic areas. Further, several hard floats are added to the surface line. These hard floats serve two purposes. First, they offer enough buoyancy so that if the botcam were dragged off the bottom into “blue water,” the entire unit, anchors and all, would simply float. A maximum of 500 meters of surface line will be added to avoid over-pressurization of any of the BotCam components. The unit could then be tracked using the radar reflector and radio beacon. Second, a surface line can be run between the high flyer and the floats to allow for a good grappling hook target for ship crews to aid in recovery of the system.

The surface line does lead to a few problems as well. First, it is an added expense and added volume of gear. Second, it is a source of substantial drag and therefore requires larger anchors to keep the botcam on location on the bottom (see drag calculations in Appendix 8). Third, it is a potential snagging hazard on both the benthos and from surface vessels as well as a propeller hazard during deployments and recovery. Finally,

while the target depths for deployments of the BotCam are below wave influence, the surface line allows wave energy to be transferred to the botcam. This motion tends to make the botcam “walk” along the bottom if not weighted well, and it makes for bouncy video that is unpleasant to view. A line weight added to the last section of line helps minimize this problem a great deal.

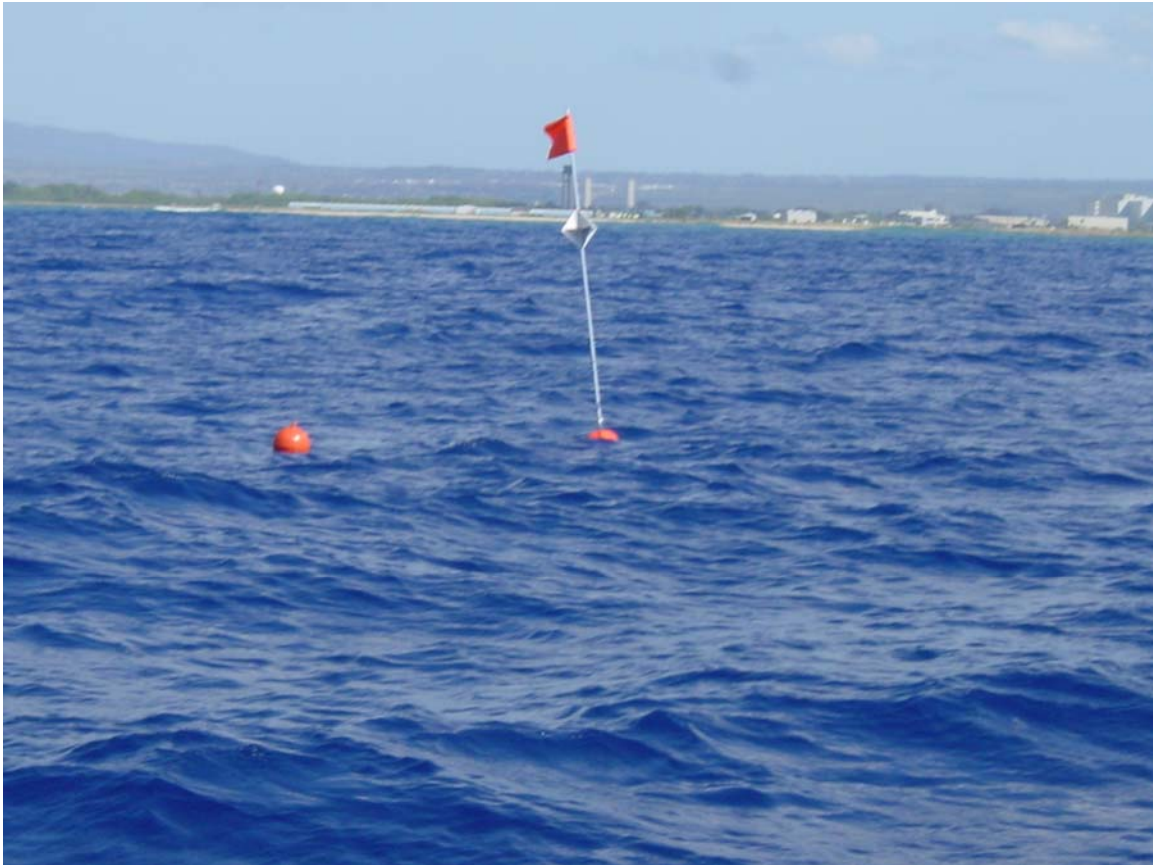

Figure 29. Botcam Surface signature.

From conversations with lobster researchers and others at PIFSC with experience deploying bottom traps, it was decided to use a floating surface line and to break the line into 20 fathom sections with swivels added between sections to help minimize tangling. These relatively short sections allow for more flexibility when deploying in various

depths. It also allows for smaller sections to be replaced as they wear or are damaged. One-quarter inch shackles and swivels were chosen to attach the lines as they will go through a standard hydraulic pot-hauler used on research and fishing vessels. A 3/8" polypropylene line was chosen as a compromise between strength and drag. Sample calculations of drag on the surface line are shown in the appendix, however, the necessary anchor weight was eventually chosen based on empirical evidence, logistical realities and risk assessment. Figure 29 below is a photo of the surface signature deployed during testing.

4.0 PROTOTYPE II TESTING

Testing of the second prototype Botcam proceeded in a similar manner to testing of prototype I progressing from land based tests, tank testing, shallow water pier testing, open water shallow deployments and finally full target depth drops. The map shown below in Figure 30 shows all of the *in situ* drops that have been performed to date around Oahu, HI.

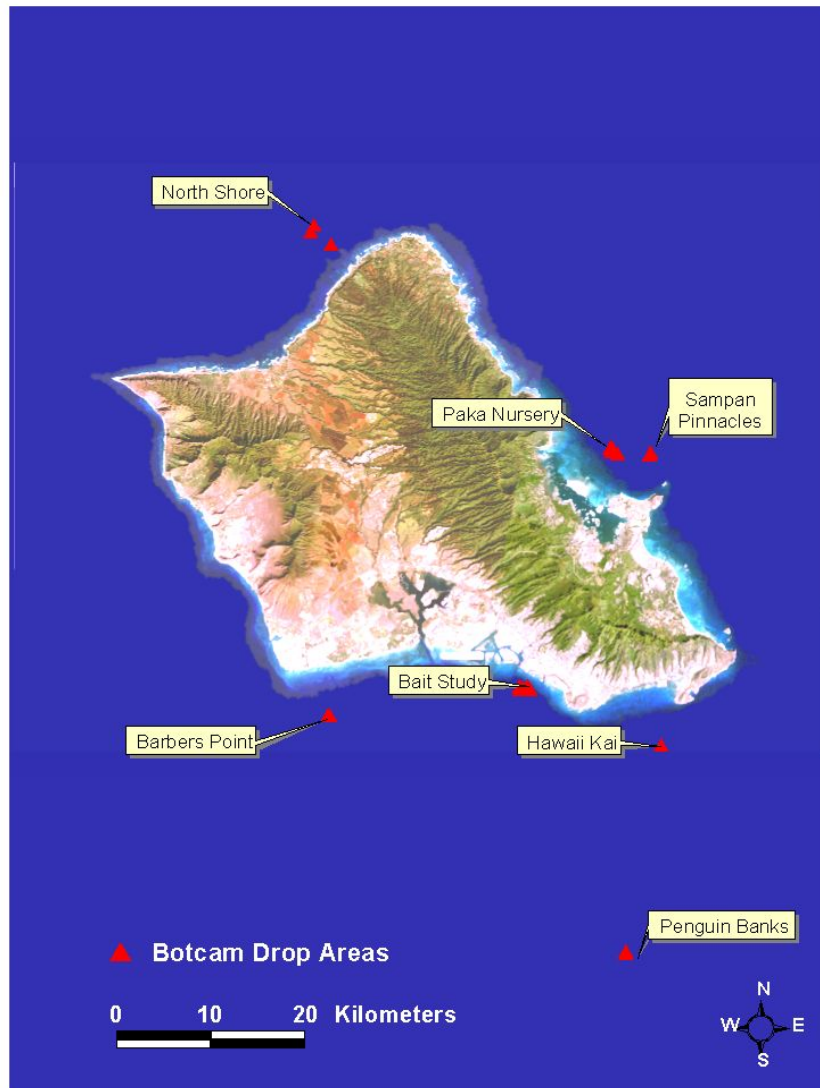

Figure 30. Satellite Image of Oahu, HI. Botcam test areas are noted (Map Courtesy of Molly Timmers).

4.1 Camera and Recorder Testing

The primary focus of the second prototype Botcam was to obtain high resolution digital images of target bottom fish species at target depths of 150 to 350 meters. Image quality from prototype I was considered too poor and CRED engineers found this to be a problem associated with both the cameras and the recording system. Therefore, several cameras were tested with two recording systems, a Viperfish Land unit provided by Deep Development Corporation and a Sony PC104 Digital Handycam. Numerical results from these tests are shown in Appendix 3. A sample of a light and dark room test using the ROS Navigator and SOSI prototype I camera is shown below in Figures 31 and 32.

These subjective tests were performed to test the low light capabilities of the cameras. All the cameras were further tested during the shallow water testing at Makai Pier described below. Based on these observations, three cameras were chosen for side-by-side testing as described below. These tests also showed the Viperfish recording system to be a viable option for further testing.



Figure 31. ROS Navigator Camera Testing. Left image lights on. Right image lights off. Same conditions apply for Figure 32.



Figure 32. SIOSI prototype I camera testing. Left image lights on. Right images lights off. Same conditions apply for Figure 31.



Figure 33. ROS Navigator camera.

4.2 Land and Tank Testing

The first Viperfish Deep unit was delivered to CRED in February 2005, but several technical issues delayed testing until early April 2005. The unit was tested in shallow water fish tanks at PIFSC's Kewalo Research Facility and proved to be relatively stable during these tests. The entire system shown in Figure 34 was integrated onto a custom-built frame designed by CRED and fabricated by MACK Machining of Honolulu, HI.

4.3 Pier Testing

On April 11 and April 13, 2005, CRED engineers and biologists tested the integrated BotCam system at Makai Pier in Waimanalo, HI (see figure 35). The unit was tested in 5 meters of water over a sandy bed. Over the two days, several tests were performed.

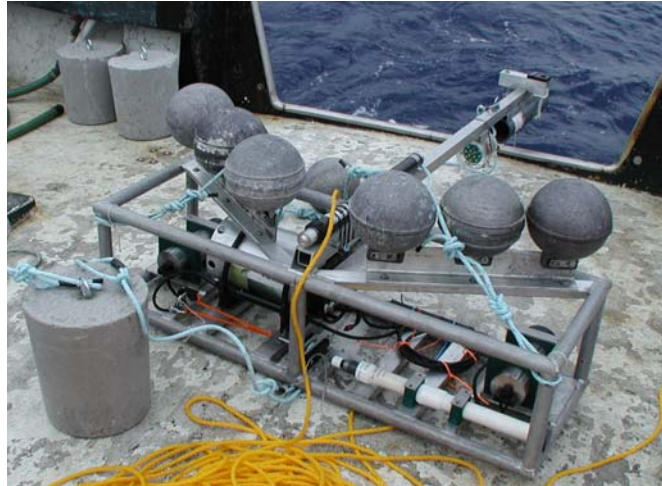

Figure 34. Botcam II prototype Frame with all components integrated.

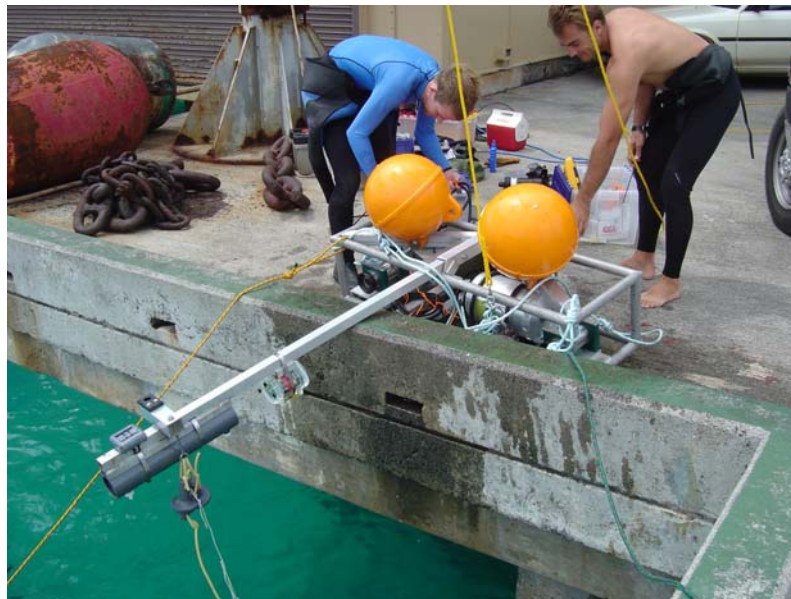

Figure 35. Testing at Makai Pier, Waimanalo, Oahu.

First, the orientation of the system on the bottom was noted and adjustments were made so that the system would align with the cameras and bait arm pointing downstream and at a slightly downward looking plane. This original design used two large mooring balls as

floatation, each providing about 45 pounds of buoyancy. It was noted that with this much buoyancy and only a 100 pound (in air) block of concrete, that the unit was barely negative and could be easily moved about by a single diver. A further problem associated with these floats was found when testing the acoustic release. The acoustic release system previously described relied on a pin being able to slide freely through a hole (see Figure 20). The large buoyant force, however, created too much friction between the pin and its hole to slide free and therefore failed to release and allow the system to float to the surface.

Next, the operation of the electronics was noted. Several problems were noted including varying files sizes, intermittent connections during video download, software glitches and bad connectors. Additionally, six cameras were tested at Makai Pier. These included the ROS Navigator, a Deep Sea Power and Light (DSPL) 5000, 2060 and 1050 (all loaned by Mecco, Inc.), the SOSI prototype I camera and a custom built camera (Watec) on loan from Scott McEntire at the Northwest Fisheries Science Center in Seattle, WA. Based on previous land based testing and this video, the ROS Navigator, DSPL 5000 and Watec cameras were chosen for additional testing.

Also, although the automated part of the bait release system had been removed to simplify the system, functionality of the Niskin bottle approach was tested by simply having a diver cut a string. The system worked OK but it was decided that additional leverage on the Niskin caps would insure proper opening.

Finally, a stereophotogrammetry calibration was attempted with using the ROS Navigator cameras. Video from these calibrations was very poor due to high turbidity and poor lighting and the second process of the calibration was not attempted.

4.4 Shallow Water Testing

After modifications were made based on the findings at Makai Pier which included using smaller trawl floats, the system was deployed on April 21, 2005 near a sea cage facility off Ewa Beach, Hawaii in about 30 meters of water to allow NOAA divers to observe the system. The system functioned well and the adjusted buoyancy caused the acoustic release system to function as planned. Bait was used in the Niskin bottle and was triggered by divers. Only the ROS Navigator cameras were used. The following day, two drops were performed off the south shore of Oahu in approximately 55 meters. Because divers would not have access to the system at these depths, perforated bait bags were strapped to the end of the bait arm. In both cases, fish (small amberjacks) were captured on video. These two drops were also the first deployments to depths beyond standard NOAA diving range. The Wailoa, a charter vessel of Cates International, was used for all of these deployments. The vessel is a 46 foot long Australian catamaran with an 18 foot beam. It also has an A-frame and a pinch-puller, both with hydraulic motors. This same vessel was used for deployments with prototype I and by all accounts, the prototype II configuration is far easier to handle on such a craft. The integration of the flotation along with the flat edges of the rectangular frame allowed the entire frame to easily slide along the gunnels making the unit much safer and faster to deploy and recover.

Additionally, although not ideal platforms, the unit was deployed and recovered from a 19 foot Safe Boat and a 15 foot Avon on several occasions (Figure 36). Although these test drops were performed in relatively shallow water, no mechanical means such as a pinch-puller was available or needed.



Figure 36. CREED 19 foot Safe Boat with NOAA RV Hi'ialakai in background.

4.5 Swimming Pool Calibration

After the failed attempts to run a calibration at Makai Pier, it was decided to attempt a calibration in more controlled environment. On April 26 a calibration was attempted at the University of Hawaii Manoa swimming pool (see Figure 37). The clear water and absence of waves, currents and sediments made for a much better environment. Further, as previously reported in Harvey et al 2003, the error associated with calibrating their system in fresh water instead of salt water was only 0.07%. Once all of the equipment

was delivered to the pool, the calibration process itself, which involves rotating the calibration cube to 20 different orientations, only took about 5 minutes.

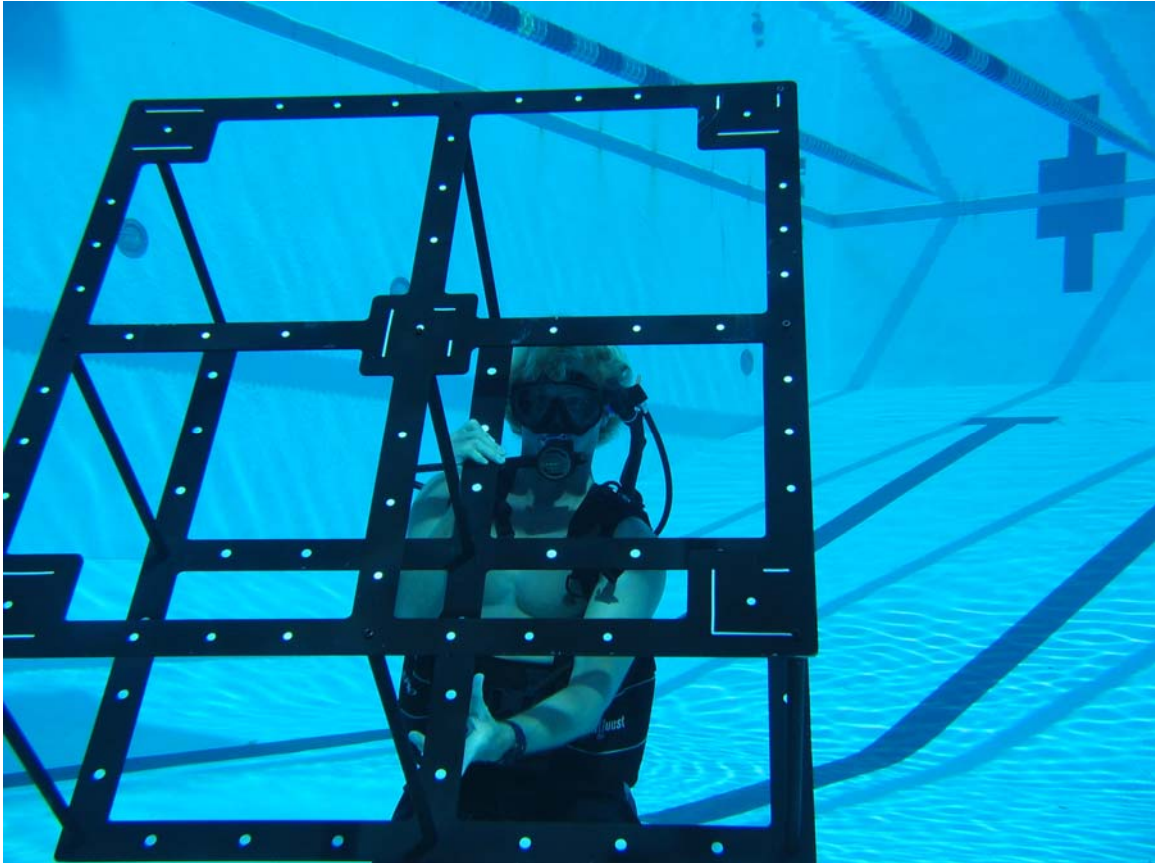

Figure 37. CRED fish specialist Joe Laughlin holds the calibration cube used for VMS software calibrations. Photo taken at University of Hawaii Manoa swimming pool.

4.6 Full Depth Deployments

The first full depth deployments of the system began on April 28, 2005 off Kaneohe, Oahu. The tests were performed aboard the Wailoa. Again, perforated bait bags were strapped to the end of the bait arm to simulate the bait release and recording commenced immediately. On April 28, three deployments were made. Two 75 meter drops were made on the opakapaka nursery grounds. A third drop was attempted on the Sampan

Pinnacle. This 300 meter deployment represented the first drop to reach full target depth. Unfortunately, we had inadvertently performed a secondary test. The battery power ran out soon after the deployment began and no images were collected at depth. The two previous deployments took well over an hour each and video was downloaded using the Viperfish Deep's power source. A conservative estimate of battery time of 3 hours is now used. However, all components survived the pressures and the acoustic release functioned properly. Although not nearly as apparent at the shallow drops previously performed, at full target depths it was found that the release process and buoyant return to the surface was a long process. The burn (or corrosion) process takes about 5 minutes once the acoustic signal is received. In addition, because the buoyancy was limited in order to allow the release pin to slide free, it took over 20 minutes for the unit to reach the surface. We soon began to start the line retrieval process about 10 minutes after the acoustic signal was sent which worked well, but still showed a limitation of the system.

The next day, two more drops were performed on the Sampan pinnacle at depths of 240 meters and 247 meters. The video collected, although somewhat dark and grainy, were of high enough resolution to differentiate and identify several targeted bottomfish species including onaga, ehu and kalekale. One problem was identified in these tests that was somewhat expected. The dark environment at these increased depths caused the stereo sync device (SVS) diodes to flush out the entire area around the SVS and also caused the rest of the image to be harder to view (see Figure 41). Smaller diodes and less power are now being incorporated on the next generation of SVS units. It should also be noted that

the flashing diodes appear to have no effect on the fish in that they do not react when the SVS flashes.



Figure 38. Satellite image of Kaneohe Bay and Windward Oahu showing the opakapaka nursery grounds (“Paka” Nursery) and Sampan Pinnacle (Map courtesy of Molly Timmers).

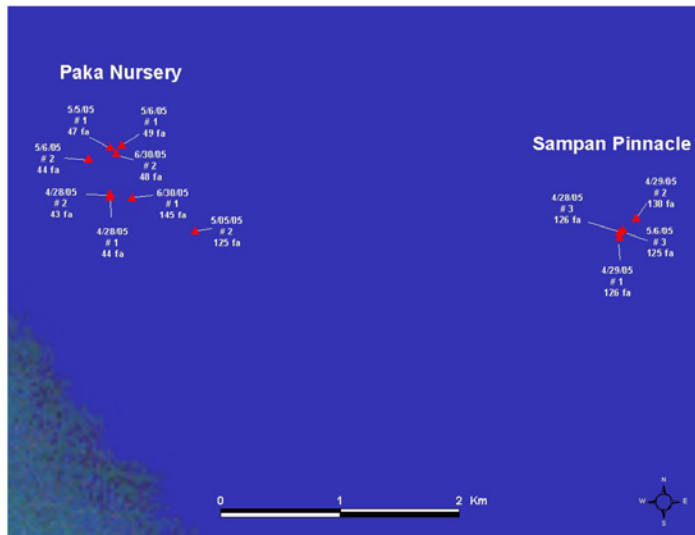

Figure 39. Close up view of BotCcam test locations on the opakapaka nursery grounds (“Paka” Nursery) and Sampan Pinnacle (Map courtesy of Molly Timmers).



Figure 40. Frame grab of video collected at Sampan Pinnacle off Kaneohe, Oahu in approximately 250 meters. Onaga in left of image.



Figure 41. Frame grab of video captured at Sampan Pinnacle showing the SVS diode running. As conditions get darker at depth, the diodes become more influential until they can no longer be individually distinguished as in this case.

The following week, the Deep Sea Power and Light 5000 and the Watec camera's were tested side by side with the ROS Navigator. On May 5, the DSPL 5000 was tested at 86 meters on the nursery grounds and at 320 meters on the Sampan Pinnacle. The camera performed well at the nursery grounds location, although was still not considered as high a quality as the ROS camera. At the 320 meter depth, the DSPL camera was clearly an inferior camera and it was felt the images would be too poor of quality to make good identifications. On May 6, the same tests were performed using the custom made Watec camera on loan from Scott McEntire from the NWFSC. This camera module is thought to be the same one used in the ROS Navigator. The first drop on the nursery grounds at 80 meters did not yield satisfactory results. The low light sensitivity of the camera seemed to be too powerful and the image, while considered reasonable, was not of the quality of the ROS. However, the video from the deep drop to 230 meters on the Sampan Pinnacle, was satisfactory. Again, the quality of the images was not thought to be as good as the ROS, but it does offer a far cheaper alternative to the ROS Navigator.

A final test of the system without the fully automated features was performed on May 7 on a site within a bottomfish restricted fishing area (RFA 7) off Hawaii Kai, Oahu (see Figure 43). High winds and a choppy, short period swell made for a much more difficult but also more realistic deployment and recovery scenario. This area was known for its strong currents and had never been surveyed by fishing because lines couldn't be kept on the bottom (Kelley pers. comm.). This area had also never been surveyed with the Pisces submersibles, so this would be the first look at the bottom in this area. The unit was deployed in 210 meters of water and it was immediately apparent that the currents were

very strong. During the units bottom time, the area was fished to see if fish were in fact in this area. Several fish were caught including a grouper, a scorpion fish, and several onaga. Upon return to the BotCam, it was apparent that something was different. The surface floats were clearly being dragged underwater, though it wasn't apparent if this was a result of the BotCam pulling them under because it had drifted to deeper water, or if it was just a strong surface current running over the top of the floats. The acoustic signal was sent as usual and the floats were approached about 10 minutes later as usual. The BotCam had clearly not dropped the anchors or had become stuck. The acoustic signal was sent again and still no luck. With no acoustic release, the unit was recovered using the surface line and the pinch-puller, a job made more difficult by the rough seas. The pinch-puller struggled to lift the weight, however, at some point, the anchors were dropped and the unit was safely recovered with no apparent damage done to the system. Analysis of the video showed that from the time the botcam hit the bottom, it was dragged down slope and down current until it had run out all 402 meters of surface line. It is difficult to say whether the unit was still on the bottom at this time as the video is too dark to identify anything. It is thought, however, that the unit was in fact floating by the time the recovery was attempted. The increased load on the release pin created too much friction to allow it to slide free and therefore the anchors were not dropped until at some point in the recovery process the load was relieved enough to allow the release pin to slide free. Based on this event, it was clear that more anchor weight was needed. Up to this point, a single 100 pound (in air) concrete block was used. It was also decided that a more conventional acoustic release should be used for future prototypes. Additionally, a problem was discovered with the bulkhead connectors on the Viperfish Deep. While

problems associated with these connectors was previously experienced, an entire pin had broken off. These connectors were of concern to CRED engineers from the start. Deep Development had chosen SeaConn HUM-K mini connectors. While these connectors are small, they are not robust and did not prove themselves to stand up to multiple engagements in wet and humid salt water conditions, and these connectors continued to cause problems throughout the remainder of testing with this first Viperfish Deep prototype.



Figure 42. Frame grab of video imported into VMS software. The left image was collected using the ROS Navigator camera, the right image using the Watec camera.

This sequence of tests proved the video solution could in fact provide high enough resolution photos at target depths in tropical waters for identification of target bottomfish species. Next, the automation of the system needed to be tested and proved. Additionally, a new acoustic release system was incorporated. A product made by IXSEA offered a compromise between our depth limitations, load requirements and cost.

This new configuration shown in Figure 22 was tested off the South Shore of Oahu on June 15 from one of CRED's Safe Boats and again on June 17 from the Wailoa.

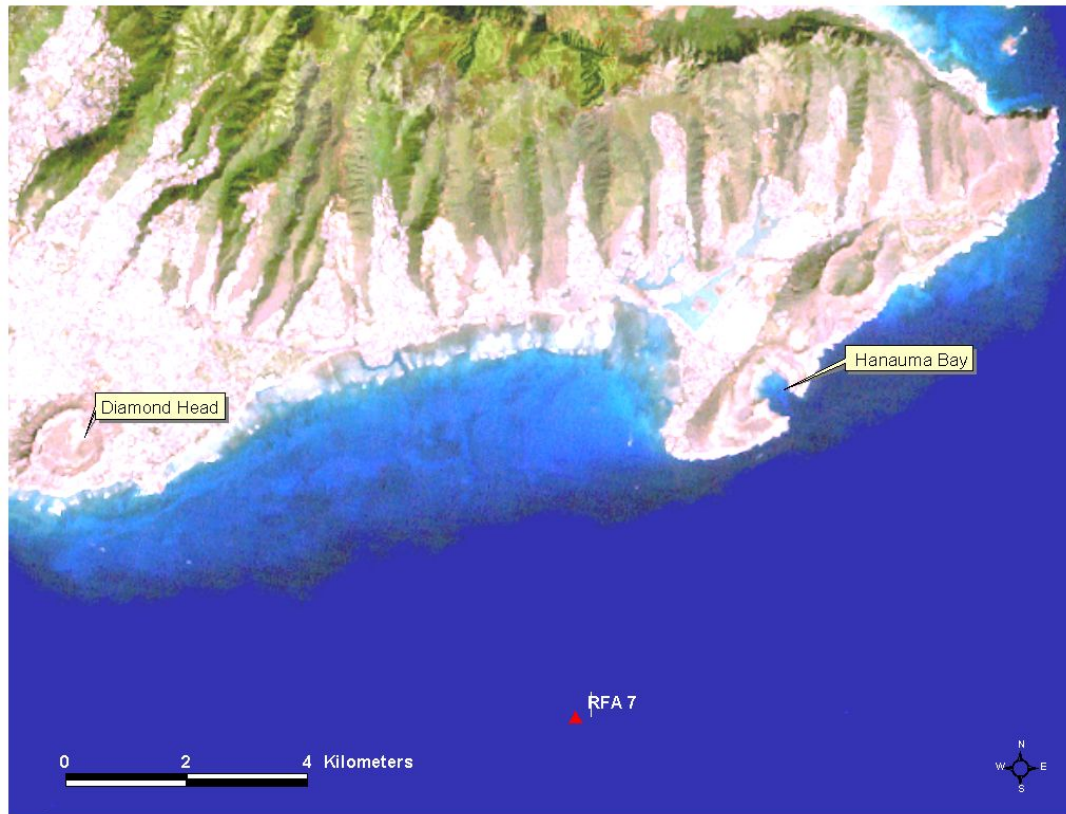

Figure 43. Location of BotCam drop in RFA 7 off Hawaii Kai, Oahu.

Connector problems caused delays but by June 30, the problem was fixed and two tests were performed at the nursery grounds off Windward Oahu in conjunction with a planned release of tagged hatchery reared juvenile opakapaka. Kelley was hoping that the juvenile fish would follow the surface line of the BotCam to the bottom and would be caught on the video. Two drops were made to 82 meters and the remote on/off and

delayed bait release functioned well. Unfortunately, however, no opakapaka (wild or released) were seen on the video.

Six final drops were carried out on July 12 and July 13 off the south shore of Oahu. Two drops were done using CRED's 25 foot safe boat AHI which proved to be a poor platform for deployments. Four drops were performed from the Red Raven, a charter vessel run by Griffith Jones out of Haleiwa, Oahu.



Figure 44. Red Raven Charter Vessel

This vessel, a 32 foot Raden, proved to be an adequate vessel for small scale BotCam operations. Drops ranged in depth from 52 meters to 177 meters and were performed in conjunction with some bait dispersal experiments which will be described later. The auxiliary can functions worked on all of these drops with the exception of 1 deployment in which the bait failed to release. It is unknown what caused this problem as the system functioned correctly with no changes after this deployment and the bait can came to the surface empty. This drop was also associated with a recovery problem and a failure of the SVS housing. The SVS appears to have failed by the time the video turns on. The

failure mechanism is unknown, but the designer Ken Sexton believes it was due to an overtightening of a hold down screw (see Figure 45). The entire system also failed to float to the surface after the acoustic signal was transmitted several times. A recovery was attempted via the surface line and eventually the weights were released part way up therefore the failure mechanism is unknown. The acoustic release locking pin returned to the surface in the locked position, however, suggesting that multiple signals were received. It is thought that the anchor lines were somehow tangled with the acoustic release. The video shows the unit to be sitting on a very steep slope which could have aided in this tangling.



Figure 45. Photo of failed SVS. The housing material around the hold down screw parted during deployment flooding the housing.

5.0 PROTOTYPE III DESIGN

Based on the finding of the extensive testing of the prototype II BotCam, a few changes were made although the basic system will remain the same. After completing testing, it is believed that the new system will solve the all of the major problems found with prototype II. The plans, parts lists, costs, and user manuals found in Appendices 4-10 refer to the prototype III system. Below is a description of the changes and additions made to the various components of the BotCam. Figure 46 is a picture of the prototype III unit deployed in shallow water.

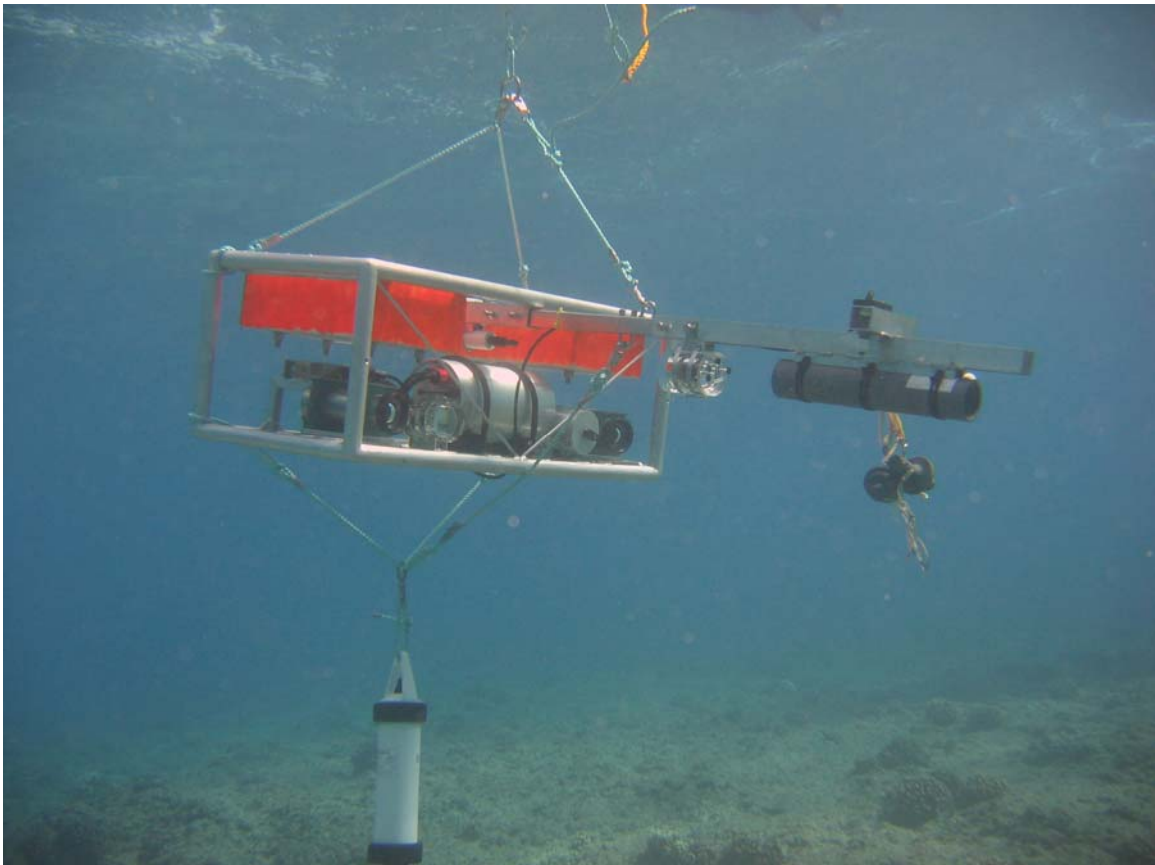

Figure 46. Prototype III BotCam deployed in 8 meters.

5.1 Viperfish Deep

While CRED engineers and biologists were relatively happy with the operation of the Viperfish Deep, the manufacturer was contacted with requests for several upgrades to make the system easier to use, more versatile, and primarily, more robust. First, it was requested that the maximum video file size be increased to 2.3 gigabytes per video stream. Based on video collected, this size file should be enough for an hour of video but will still allow both video streams for any single deployment to be archived to a single DVD. Next, robust connectors were requested. Cable and connector problems have caused the biggest problems during testing on both prototype I and II. These problems are doubly problematic as they are often intermittent and difficult to locate. Despite the concern over connectors, more bulkhead connectors were requested. The Viperfish Deep prototype unit tested was capable of recording 4 independent video streams, however, connections were only provided for 2 cameras via a single connector. Two camera connectors were requested that could accommodate up to 4 cameras. Three more connectors were requested to be used for charging and power, for the bait release burn wire signal, and for video download and communications. It was also suggested that these connectors be sufficiently different to avoid a connector being plugged into the wrong plug and causing damage to the system or component. The remote operation of the unit was to be moved inside the Viperfish Deep and the auxiliary can removed from the system. A separate sub-system is to be used to supply power to the bait release burn wire, so only a high-low triggering voltage was needed from the Deep unit. Finally, a time and date stamp was to be added to the system.

5.2 Stereo Video Sync (SVS)

As previously mentioned, the diodes of the SVS were found to be too bright at depths greater than a couple hundred meters. Prototype III will use a unit with both smaller diodes and lower power settings. Even if the unit is still too bright, it will serve its purpose as the left and right images can be synchronized by the start of the SVS turning on. In fact, this original design may be more complex than is needed, however, further testing is required.

5.3 Burn Wire Relay (BWR)

As part of the overall compartmentalized design of this system, an independent power supply for the bait release burn wire system was sought. It was critical, however, that the bait release be linked to the video capture. The time of bait release relative to the start of filming is a vital statistical measure. A +/- 5 volt signal was integrated into the Viperfish Deep. A ten minute high signal starts when the unit boots and begins to record. After the ten minutes, the signal goes low.

Based on this scenario, specifications were drawn up for a battery pack and relay system that would input the high low signal from the Viperfish Deep, and output the appropriate power to the burn wire. Several vendors submitted quotes and a design presented by Sexton Photographics was chosen (see Figure 46). The system uses an industrial relay which remains on with a 5 volt high signal and is off otherwise. A custom made rechargeable battery and charger are also provided. The unit is based around the same housing used for the SVS.



Figure 47. Burn Wire Relay (BWR)

5.4 Surface Signature

Although the surface signature and surface line used for prototype II was perfectly acceptable, a couple minor modifications were made. First, new rope called Blue Steel was chosen that is specifically designed for use with bottom traps and long term use in a pot-hauler or pinch-puller. This line is also slightly stronger than standard polypropylene of the same diameter. During the relatively small number of drops performed with the polypropylene line, it was found the line was quickly being “eaten” by the pinch-puller of the *Wailoa*.

Second, in order to stream-line the system, a single large mooring ball will be used as the surface floatation rather than multiple smaller balls. The single 24 inch diameter mooring

ball is also made of a closed cell material so is capable of being bumped by ship hulls without cracking and losing buoyancy.

5.5 Frame Design

The biggest change between prototype II and III is in the frame design. The design was based around a couple of fundamental ideas. First, all of the systems components and flotation should be captured within the frame with the exception of the bait arm, burn wire, bait release container and SVS. Second, a compact solution was sought that could be easily stored and shipped.

Integration of the flotation was made easier when the decision was made to use syntactic foam rather than air filled mooring or trawl floats. While syntactic foam is relatively expensive compared to hard floats, it is far more space efficient and it can be machined to any shape. The primary benefit, however, is that even if it takes a hard impact from any number of foreseeable and unforeseeable scenario's, it will remain buoyant. A preliminary weight analysis for design purposes (see Appendix 7) shows that the latest configuration should provide sufficient positive buoyancy. Only two companies were identified that make syntactic foam for sub sea applications and a product from Flotation Technologies was eventually chosen.

Integration of the flotation increased the overall dimensions of the frame but the overall space is used far more efficiently. Width of the system decreased slightly and the camera separation was decreased from 40 inches to 36 inches. This decrease combined with a 5

to 10 degree “toe in” of the cameras will allow the bait arm to be shortened. The bait arm will also sit slightly higher in the field of view of the cameras allowing for less interference and a larger viewing area of the surrounding area. The camera configuration was chosen based on the behavior of fish filmed during testing. In some cases, fish approached the BotCam so closely that they were not captured on both cameras, and therefore, could not be measured. The narrowing of the cameras base separation also allows the overall width of the frame to be confined to a 4 foot outside dimension. The outside width was also limited to 22 inches, meaning that 2 BotCam units can be stored on a standard 4 foot by 4 foot crate for storage and shipment. Furthermore, the increased size of the frame allows for the broken-down bait arm and acoustic release to be stored within the frame as well.

The configuration of the bait arm was also changed slightly. First, loading bait into the Niskin bottle on a rocking boat using the bait arm used on prototype II was more challenging than necessary. Storage of the bait arm was also a bit of challenge and as noted above, an integrated storage solution was sought. Therefore, the bait arm was broken into two sections. The first section is essentially just an extension piece to get the SVS and bait release container the appropriate distance from the cameras. The second section holds the bait container, bait release burn wire and SVS. This allows a much smaller section of arm to be removed in order to change the bait and as previously mentioned, allows the entire arm to be stored within the botcam frame. Additionally, because the bait arm is the most exposed part of the botcam system but a relatively minor expense, it is proposed that multiple bait arms be provided. This will also help increase

the turn around time of systems as the bait can be pre-loaded and batteries changed in the SVS as necessary.

A slightly heavier 1-1/4 inch schedule 40 aluminum pipe was chosen for the primary frame material. This will help to maintain the rigidity of the system over time as the system is exposed to impacts and other wear and tear. Also, this material is readily available. Special 1-1/4 inch aluminum pipe corners were also located that will simplify the machining and fabrication process while eliminating any sharp edges. Several holes will also be drilled into the pipe at regular intervals to help with drainage and to decrease weight slightly. Even with this heavier material and larger frame, the entire unit without anchors is expected to weigh approximately 150 pounds in air and to be approximately 10 pounds buoyant in water. The system should be easily manipulated by two people. Both solid stainless steel and aluminum rod was considered as an alternative to pipe, however, weight of both systems became excessive and the larger diameter pipe was also thought easier to handle.

6.0 RESULTS AND CONCLUSIONS

The goal of this thesis was the development of a new ecosystem based tool that will allow scientists to monitor and study bottom fish species and habitats in tropical oceans around the world. This tool which was created is unique in its ability to make stereophotogrammatic measurements at depths greater than 300 meters with no artificial lighting. The tool can be deployed in a variety of habitats with minimal impacts to the ecosystem. It can also be deployed and recovered from a variety of vessels ranging from 15 foot Avons to 200 foot research vessels. It is compact, lightweight, and rugged. All of the original specifications have been met.

Acceptance of this tool will require a new way of thinking about fisheries science and management. The trend as of late has been to move to ecosystem management rather than species specific management. This is a tool that can help to start answering some of these broader questions; however, it will take a paradigm shift by people to accept it. As Frank Parrish noted, using this tool we need to start thinking in terms of “sightings per unit effort” rather than “catch per unit effort.”

The advantages of this system over alternatives such as fishing and acoustic surveys are clear. It is non-extractive, allows precise identification of all species in an area as well as identification of habitat, and it allows for the study of behavior. It should be noted, however, that video has a powerful ability to capture people’s imaginations very quickly. As we begin to use this new tool, we need to be rigorous in our sampling strategies and statistical analysis.

7.0 FUTURE DIRECTIONS

The primary goal for the immediate future of the BotCam is to get the unit out in the field collecting data as much as possible. The system still needs to be proven as reliable and effective tool for scientists and managers. Further, several logistical issues regarding ship operations will only be worked out by operating the system. This being said, there are several immediate and long term directions that are suggested.

7.1 Anchoring Problem

The issue of how to anchor the BotCam, what type of anchor to use and whether to sacrifice anchors on every drop or attempt a recovery of the whole system has been an ongoing problem since the start of this project. The steep slopes and rugose terrain that are expected in target regions make direct placement of the camera frame on the bottom an extremely difficult problem. The buoyant BotCam system employed is a simple and effective method for insuring proper orientation of the system when recording. It also minimizes the chances of damaging or even losing the whole system that are likely from direct contact with the benthos.

It has also been debated whether leaving a sacrificial weight behind is actually better for the environment than attempting a recovery. Trying to pull 500 meters of line up from depths of 300 plus meters from a large ship is bound to cause the anchor to drag along the bottom impacting everything in its path. This method of retrieval would also risk lodging the anchor into holes and large underwater features causing the whole system to be stuck.

Finally it would risk damage to the BotCam itself if it were to be dragged along the bottom or pulled into a large benthic feature.

While several options are being explored including the use of sand bags or pea gravel in place of concrete as well as options to recover the anchors, for the near future, concrete blocks will be used. It is felt that concrete, being primarily limestone, is relatively inert and the small number that will be used in the next year will have a minimum impact. However, concrete causes its own logistical problems. For those that were involved in the testing of prototype II, the first thing they will say about the BotCam is that they now hate concrete. Blocks used in testing were limited to 100 pounds in order to allow a person to manipulate them, but not easily. While concrete is heavy on land though, it's low density means it weighs about 50% of its dry weight in water. A single block was used for most testing, however, experiences showed that this was not nearly enough for all circumstances. Testing in the near future will use a minimum of 200 pounds of anchor as a result of previous testing. Even this weight is considered too light based on the drag calculations shown in Appendix 8, however.

While hauling around enough concrete for a single days operations is hard work, most daily work vessels can handle enough weight for five deployments. However, when planning started for a 60 day cruise to the Mariana's Islands with an estimated 100 potential BotCam drops, weight and volume becomes more than a back-breaking issue. Simple estimates yield 20,000 pounds of concrete that would have to be placed on eleven 4 foot square pallets, each about 18 inches tall. In fact, the NOAA R.V. O.E. Sette will

not allow CRED to transit with all this concrete, therefore, the anchors are being made in Guam and Saipan and delivery will be broken up by each 10 to 20 day leg of the cruise. In this case, only one BotCam is being accommodated. Clearly, a new solution will have to be found to allow as many as 10 to 20 units per cruise.

7.2 Testing the stereo-video precision and accuracy

Although Harvey, Shortis and others have performed numerous tests to prove the precision and accuracy of the VMS system, each system must be proven individually because of the variability in cameras, video resolution, system configuration and the working environment. Several tests are being proposed to test both the system and those that will be analyzing the video, as this is a somewhat subjective process. The effects of fish size, orientation, distance, and swimming speed, as well as water depth, water clarity and light availability are all important variables to test with the VMS system.

7.3 Drive down the overall cost of units

CRED currently has the necessary components to build a total of 3 of the current BotCam units. However, future funding is unlikely. This is unfortunate as much of the engineering costs have all ready been spent and we are now moving into the production stages of the development process. Still, at approximately \$38,000 each, these are still expensive instruments for most research groups. Furthermore, these high costs will limit the number of units even well-funded agencies can purchase. This is a problem, as it is recognized that it will take a large sampling regime to say anything intelligent about data collected.

Therefore, driving down the overall cost of units is a high priority. The cameras account for over 1/4 of the total cost in this iteration of the BotCam. It appears that this is the best place to start cutting costs, however, testing to date has yet to find a suitable alternative that will provide useful data.

7.4 Bait plume modeling using visual methods

One of the primary problems associated with baited stations is understanding the dynamics of the bait dispersal (Cappo et al 2002, Willis et al 2000). While the instrument can be used in a relatively straightforward manner as a relative index tool for spatial and temporal comparison, in order to begin to translate numbers into density, it is critical to know the region of influence of the bait plume over space and time.

Ultimately, NOAA Fisheries would like to be able to use camera bait stations to measure fish density in a given area (i.e. how many fish are there in a given location). While this is a lofty goal given the complexities of ocean dynamics and fish biology, it is believed that a camera bait station can readily be used as a relative indexing tool to measure both temporal changes and spatial differences in fish populations.

In order to understand the area of attraction that a given bait plume is affecting, several factors must be considered such as current speed and direction, turbulence and mixing, fish swimming speed and the threshold amount of bait needed for a given fish to recognize the bait plume.

Due to the dynamic nature of ocean currents, even as a relative index tool, it is important to understand both the current speed and direction as well as the amount of mixing that is occurring for each deployment. Several groups have attempted to explain the bait plume. Sainte-Marie and Hargrave (1987) took a fairly rigorous approach while Ellis and DeMartini (1995) made several assumptions. The typical approach in the past has been to deploy a current meter either alongside or attached to the bait station. However, because of the complex nature of bottom boundary layers and its role in mixing, this becomes a non-trivial problem. Further, current meters can be excessively expensive and bulky to be incorporated on every bait station deployment.

The use of visual cues to determine current speed, current direction and mixing has not been thoroughly tested. A major advantage of using a stereo-video system with the VMS software is that three-dimensional space is created. Using this feature, it is thought that it may be possible to measure the dispersal of the bait plume using the video obtained from each deployment.

In order to test this idea, six deployments were made off the south shore of Oahu on July 12 and 13, 2005 in conjunction with the simultaneous deployment of two Aanderaa RCM-9 directional Doppler current meters and a Sontek 250 kHz upward looking acoustic Doppler current profiler (ADCP). The ADCP was deployed in the general area of interest at the beginning of each day and was rigged to begin profiles at 7 meters from the bottom. The primary role of the ADCP was to measure the free stream velocity of the

entire water column, however, it was also hoped that the instrument may catch part of the bottom boundary layer. Ideally, the ADCP would be placed as close to the bottom as possible. However, equipment immediately available to CRED for mounting the ADCP limited the ability to get very close to the bottom. The ADCP was set to sample 50 two meter bins and averaged 18 second bursts every minute.

The two Aanderaa current meters were positioned as shown in Figures 49 and 50 below. These units operate at 2 MHz and measure an area between 0.4 and 1.8 meters from the unit. The meters were set to continuous sampling and averaged current speed and direction over 18 second periods. While this averaging interval was longer than the wave frequency on both days, waves do need to be considered when setting up this averaging, particularly for shallow deployments and long period

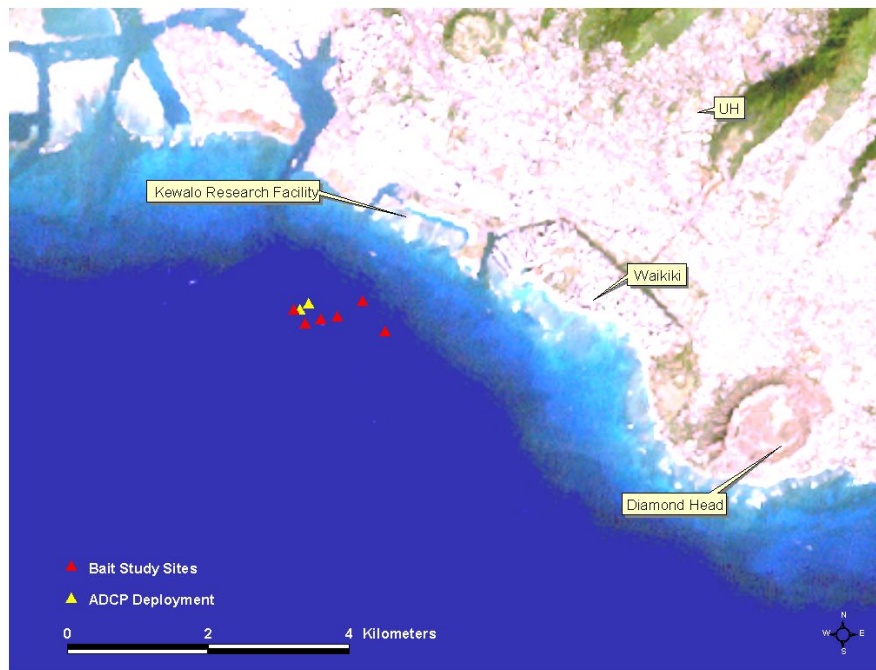

Figure 48. Satellite Image of South Shore Oahu Bait Study Sites (Courtesy of Molly Timmers).

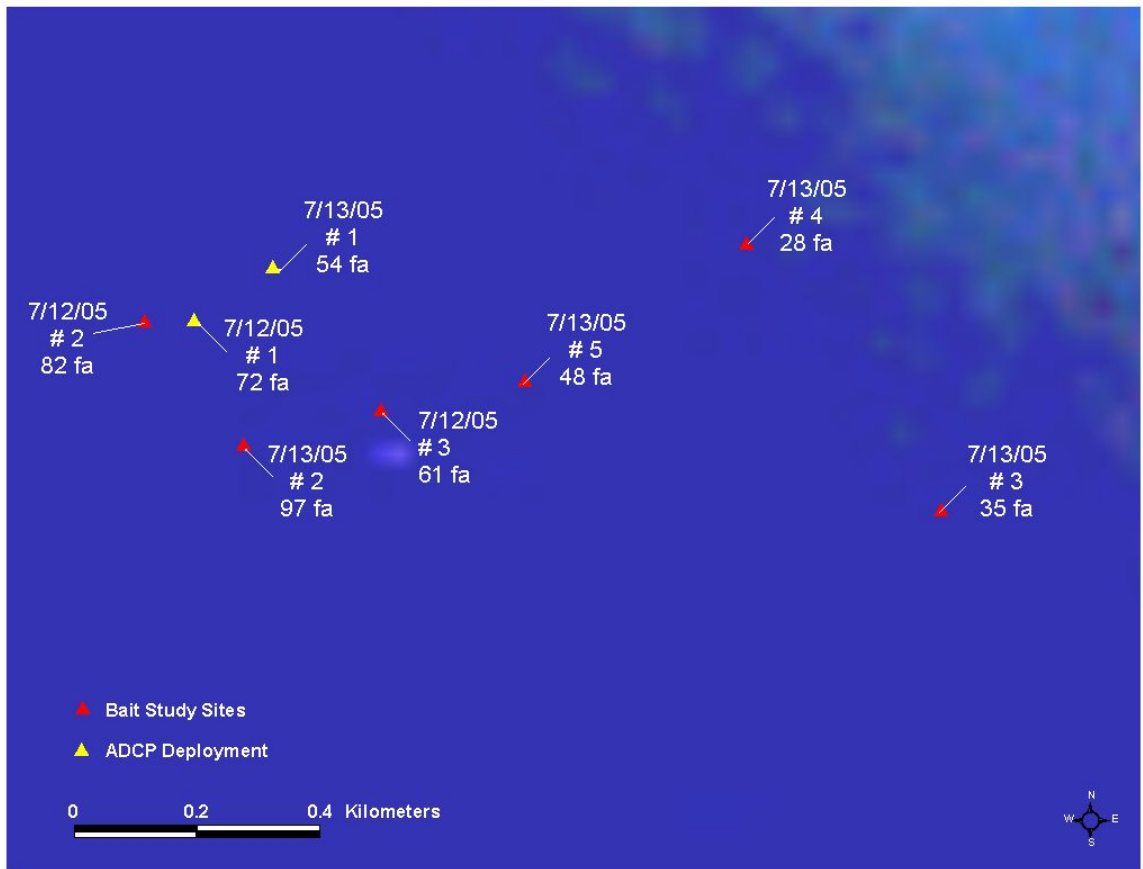

Figure 49. Bait Dispersal Drop Sites off Kewalo Basin on the South Shore of Oahu.

swell events. These meters were meant to directly measure the bottom boundary layer. At the depths that BotCam deployments are targeted for, waves are generally not of concern and currents are generally steady on time scales of tens of minutes. Therefore, for the time scales that we are concerned with for bait dispersal, we can assume that we are dealing with a fully developed steady turbulent boundary layer. Furthermore, we can then assume a log layer current profile (Pawlak 2005). Log layers can be defined by two point measurements within the boundary layer. With this in mind, one of the meters was set below the BotCam, and the other above it. Again, assuming the BotCam is stationed

within the log layer and by knowing the distance of each of the meters measurements from the bottom, the boundary layer can be defined by as shown below in equation 1.

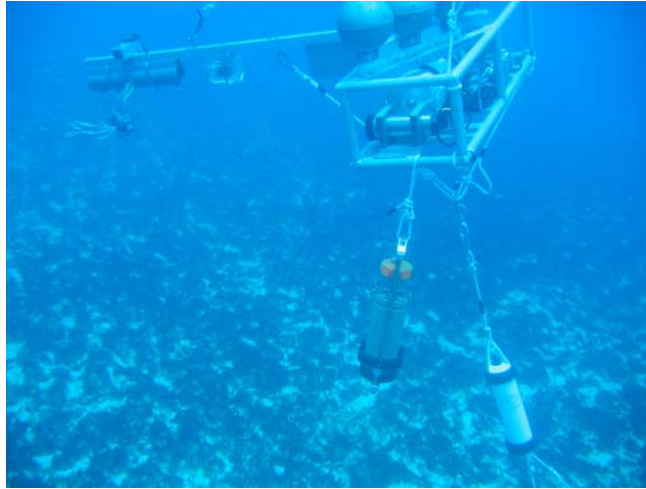

Figure 50. Bottom Aanderaa Current Meter

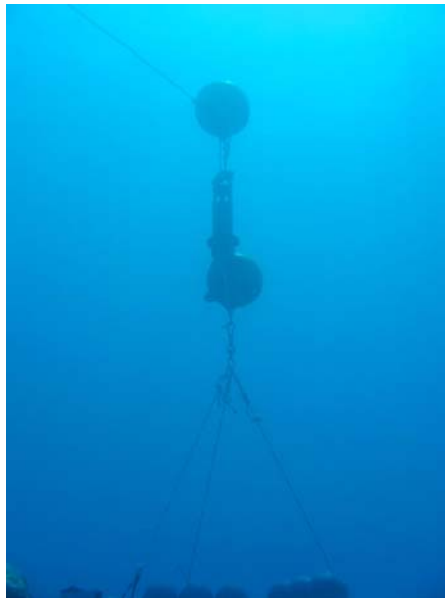

Figure 51. Top Aanderaa Current Meter

With these two sources of current information, we have two independent methods for arriving at the bottom shear stress which will lead us to our desired outcome of a dispersion coefficient. First, using a free stream velocity found from the ADCP data and assuming a bottom drag coefficient, we can determine shear stress. Second, the log layer calculation leads directly to a friction velocity which is proportional to shear. Therefore, if we assume that some portion of the released bait acts as a passive tracer, then we can model the dispersal of the bait by shear dispersion and come up with two independent dispersion coefficients.

Ultimately, the goal of this experiment is to eliminate the need for any current meters. If the bait cloud can be visualized by the video and the size and distance measured temporally using the VMS software, then current velocities and dispersion coefficients can be directly measured. Direct comparison of the current velocities found from the instruments and from the video estimates can be made along with an assessment of the three dispersion coefficients.

Fully Developed Turbulent Log Layer Profile
(Pawlak 2005)

$$U_{top} - U_{bot} = \left(\frac{1}{\kappa}\right) u_* \left(\ln \frac{d_{top}}{y_0} - \ln \frac{d_{bot}}{y_0} \right) \quad \{\text{Eq. 1}\}$$

U_{top} = upper current velocity (measured)

U_{bot} = bottom current velocity (measured)

κ = von Karmen constant ~ 0.41

u_* = friction velocity

d_{top} = distance from bottom to top current meter measurement location (known)

d_{bot} = distance from bottom to bottom current meter measurement location (known)

y_0 = roughness

solving for the friction velocity u_* :

$$u_* = \frac{(U_{top} - U_{bot})\kappa}{\ln(d_{top} - d_{bot})} \quad \{\text{Eq. 2}\}$$

Bottom Boundary Layer Flow with Mean Free Stream Velocity
(Fox and McDonald 1992)

$$\tau_0 = \frac{1}{2} \rho C_D U^2 \quad \{\text{Eq. 3}\}$$

τ_0 = bottom shear stress

ρ = water density

C_D = drag coefficient $\sim 2.5 \times 10^{-3}$ (typical value for rough boundary layers)

U = free stream velocity \sim some average value from ADCP data

solve for friction velocity u_* using relation:

$$u_* = \sqrt{\frac{\tau_0}{\rho}} \quad \{\text{Eq. 4}\}$$

Want to compare Dispersion Coefficients, D [L^2 / t]

Using VMS software, measure D directly:

$$D \approx \frac{(L_{t_2} - L_{t_1})^2}{t_2 - t_1} \quad \{\text{Eq. 5}\}$$

L_{t_2} = Bait Cloud Size at Time 2

L_{t_1} = Bait Cloud Size at Time 1

t_2 = time 2

t_1 = time 1

Using a derivation from Clauser (Clauser 1955):

$$\frac{\epsilon}{\rho} = ku_* \delta = D \quad \{\text{Eq. 6}\}$$

ϵ = eddy viscosity

ρ = water density
 k = constant ~ 0.018
 u^* = friction velocity
 δ = boundary layer thickness \sim approximate from ADCP data

Note: The dispersion coefficient from this derivation should apply to both vertical and horizontal dispersion over small distances as it is essentially a measure of turbulence. We also have to assume in this case that the boundary layer is not stratified. Stratified flows have added complications. These can be accounted for however, if the stratification can be defined such as with CTD casts.

Using the above theory, 6 deployments were attempted of which 5 provided bait release images. Of these 5 drops, 4 of them included the use of fluoroscene dye which was found to dramatically improve the ability to view the bait release and subsequent dispersal. Complete results from these 5 drops are shown in Appendix 12. Below is the plot of velocity correlation between the VMS measurement technique and the Aanderaa current meters.

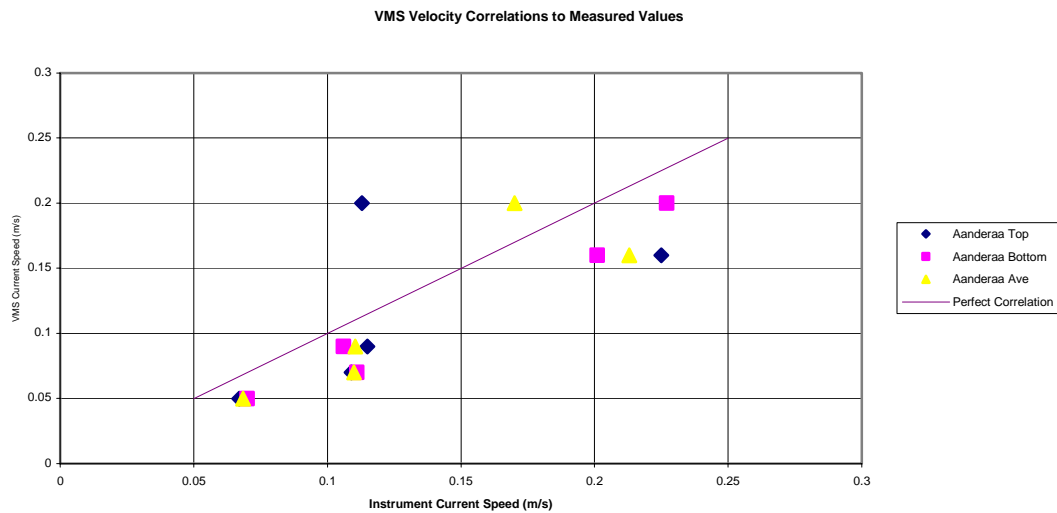

Figure 52. VMS Velocity Correlations to Measured Current Values Using Aanderra RCM-9 Current Meters. The VMS measurements are compared to both the top and bottom meters as well as to an average value of both meters.

The VMS data was collected by attempting to click on approximately the same location on the bait plume from one frame to another yielding a distance and a time. Measurements were made by measuring from left to right, right to left, top to bottom, bottom to top and to the center of the bait cloud. Each of these measurements was then repeated every five seconds until the bait cloud could no longer be clearly identified.

The results of the experiment were inconclusive and it is thought that there are some problems associated with the Aanderaa meters. Additionally, only two of the deployments provided bait releases that could be measured to any extent over an interesting length of time. Rapid spreading of the bait, steep bottom slopes and bait arm interference hampered visualization of the other three drops to a large extent. Furthermore, while the fluoroscene dye provided for good contrast, the interpretation of edges and points which is needed for accurate measurements with the VMS software was very subjective and it proved very difficult to define a single common point in the left and right images.

That being said, the average current velocities that were measured by these visual techniques were at least found to be on the same order as the current meter measurements. Although individual deviations are large, if numerous measurements can be made, reasonable values can be found. The spreading rates found were considered pretty useless. The inability to clearly define a single point in both images and the relatively small distances associated with both the horizontal and vertical spreading over the time and distance that the bait remained visible made the measurement errors large.



Figure 53. Bait Dispersal Measurement. The bait cloud is measured as it moves away with the current. The bait cloud is enhanced by using flourescene dye.

Although the results from this preliminary study were not satisfactory, it is believed that the method is sound. Placing an ADCP closer to the bottom will allow the boundary layer to be more accurately measured. To this end, a 600 kHz ADCP has been procured by CRED for such deep water studies. This higher frequency unit will also provide higher resolution profiles. Additionally, it will be necessary to stabilize and ground truth the current meters used for single point measurements. It is thought that beam interference could be one possible problem associated with this data. These instruments will be able to provide the best estimate of current speed right at the BotCam as the ADCP cannot be deployed too close to the unit as the BotCam will interfere with the beams. More thought will need to be given to the bins sizes and sampling intervals used as well. Finally, it is thought that if some kind of neutral buoyancy particles could be added to the bait in addition to the dye, they may provide for clearly defined points that

could be accurately measured with the stereophotogrammetry system. The new frame design should also provide less interference at the top of the video images which will allow for better measurement.

7.5 Automation of analysis

Even though \$38,000 per BotCam seems like a pretty expensive instrument, this cost is really minimal relative the manpower it will take to extract useful data. Anyone that has worked with video knows that video analysis is a time consuming process. Euan Harvey has suggested that analysis of his video using VMS is about a 3 or 4 to 1 ratio, meaning that for every hour of video collected, a person will have to sit in front of a computer for 3 to 4 hours essentially pointing and clicking on objects. As an example, if 100 thirty minute drops were performed on the upcoming Marianas cruise for a total of 50 hours of video, it should be expected that a person would spend between 4 to 5 full time weeks analyzing the video. Further, this analysis would require some professional skills and training. This suggests that for every BotCam, a full time trained person could be employed just to analyze the data, a daunting thought.

To this end, one of the main goals of Harvey and Shortis is to begin automating VMS. Techniques include pattern recognition techniques, many of which are used in industrial applications. However, biological systems are a whole new ball game as there is a tremendous amount of variation not only in the flora and fauna but also in the environmental conditions. This being said, several systems have all ready been developed in fish farming applications. In a presentation at the National Marine Fisheries

Service video workshop, Euan Harvey was hopeful that the VMS software would soon allow a single click on a fish to make measurements, with the ultimate goal of the whole analysis process becoming a black box to human interface. If this happens, video will become a highly valuable tool to the biological scientific community.

8.0 APPENDICES

8.1 Appendix 1: Botcam Prototype II Frame Concepts

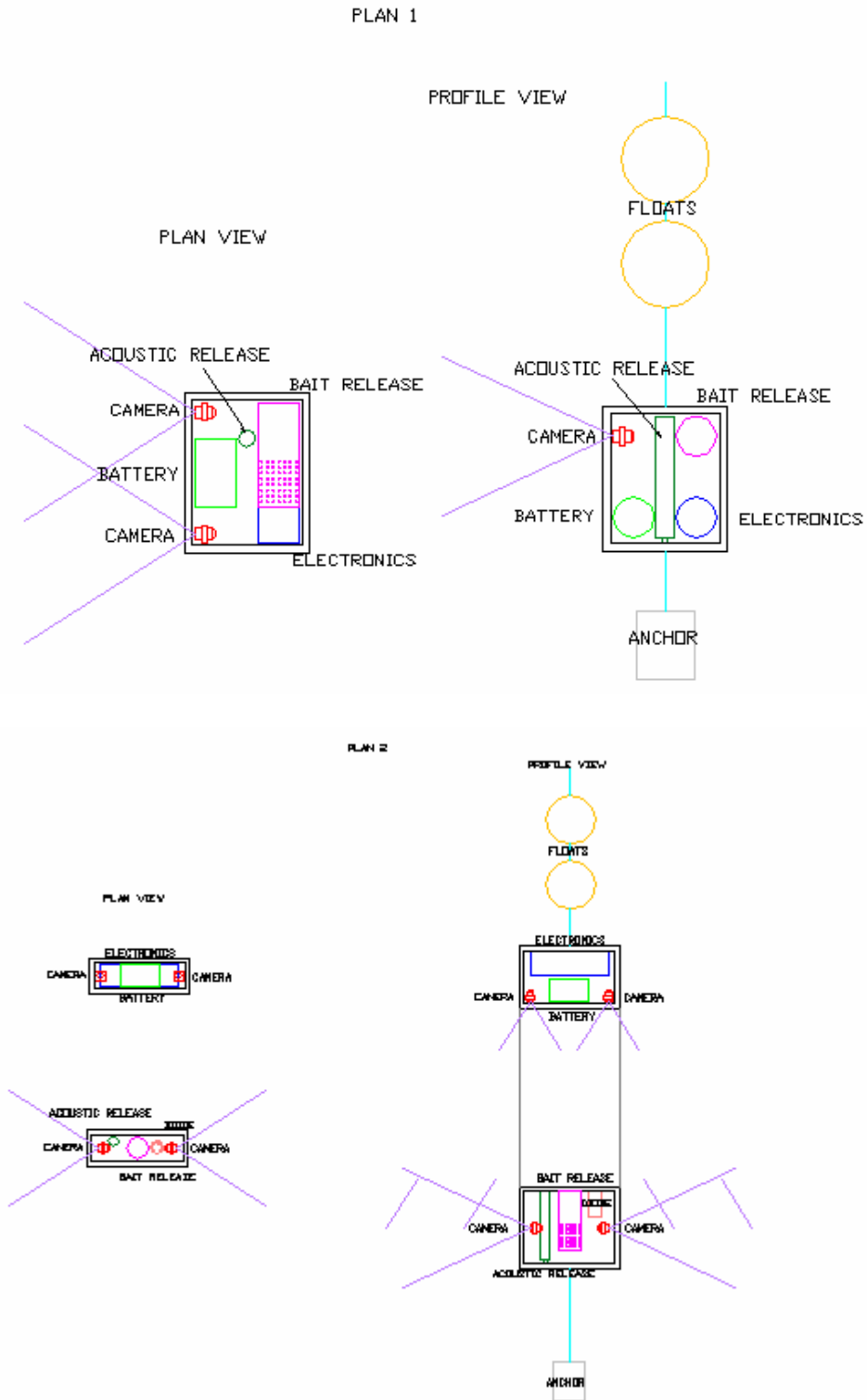

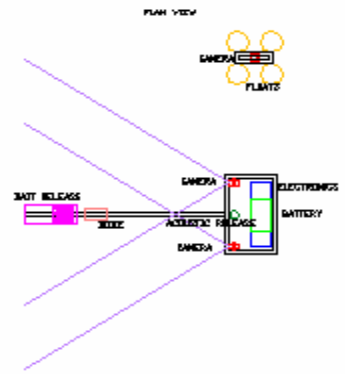
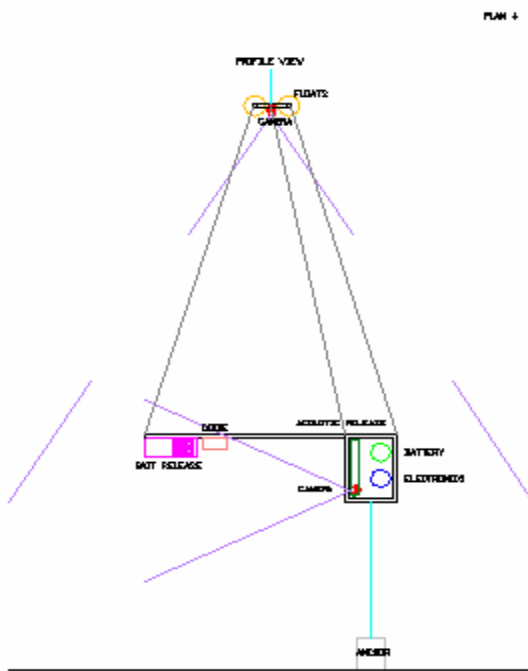
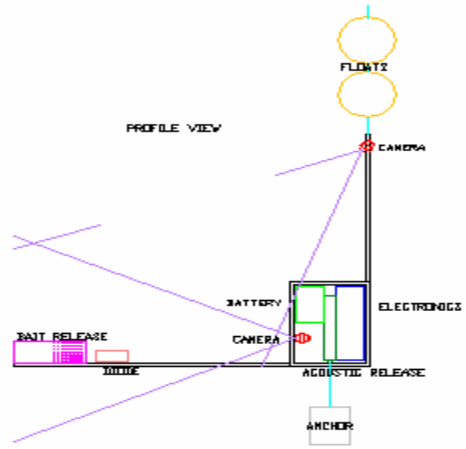
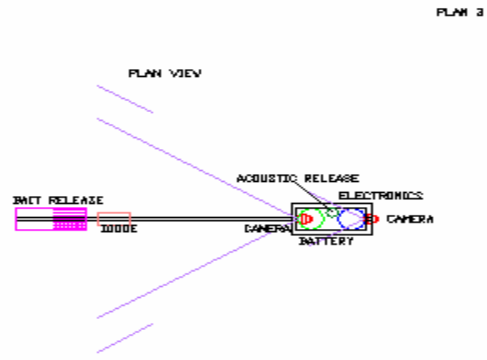

PLAN 3

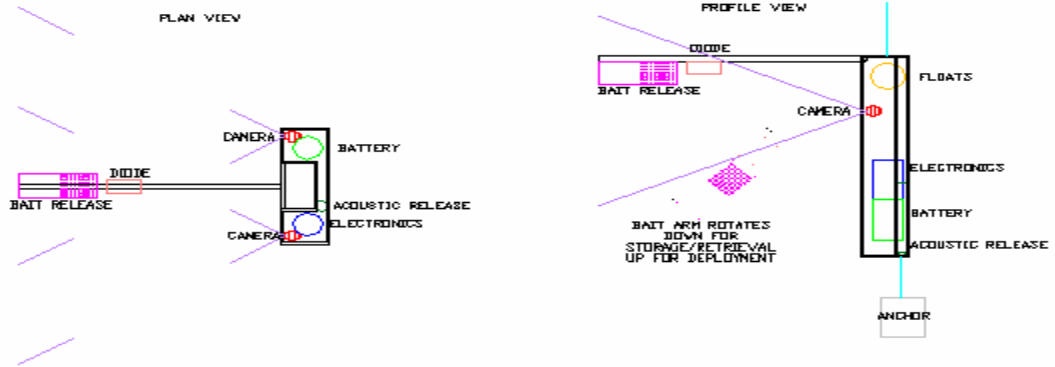

8.2 Appendix 2: Camera Comparison Matrix

	DeepSea Power and Light		Remote Ocean Systems		Kongsberg			SOSI		
	Multi SeaCam 1060	Super SeaCam 5000	Navigator	20/20 ICCD	oe15-1C27103	oe15-100/101	oe1358/59	oe1324	version 1	version 2
Mechanical										
Housing	Delrin/Titanium	Titanium/Aluminum	Titanium/Aluminum	Aluminum (std) SS or Titanium (opt)	Titanium	Titanium	Aluminum	Titanium		
Port	Sapphire	Optically Polished Glass			Plano-Concave	Plano-Concave		Plano-Concave	sapphire	sapphire
O.D.	4.74cm	9.45cm	10.16cm/10.67cm	9.4cm	10.3cm	9.3cm	6.2cm	10.2cm		
L.O.A.	12.95cm	25.2cm	24.26cm/24.08cm	32.97cm	22.0cm	24.7cm	16.3cm	29.7cm		
Weight Air	296g/459g	2.95kg/1.86kg	2.58kg/2.15kg	2.19kg	3.2kg	2.2kg	1.0kg	4.6kg		
Weight Water	56g/112g	1.54kg/0.43kg	1.05kg/0.29kg	0.875kg	1.6kg	1.0kg	0.5kg	2.2kg		
Optical										
Lens	5mm f2.8	3.8mm f0.8	3.8mm f0.8		6.5mm f1.8	3.8mm f0.8	3.7mm f1.6	6.5mm f1.8	2.7	2.0
Focus	fixed	fixed	fixed		fixed	fixed	fixed	fixed		
Iris		automatic	automatic		automatic	auto/manual over-ride	automatic	automatic	auto	auto
Depth of Field	30cm to infinity	60cm to infinity	6" to infinity		150mm to infinity	100cm to infinity		15cm to infinity		30cm to infinity
F.O.V. Air	77deg x 56deg									
F.O.V. Water	57deg x 45deg x 71deg diag	108deg x 96deg Dome 80deg x 69deg Flat	94.59deg diag w/ water corrected port	110 deg (6.5mm) 65 deg (12.5mm)	86 deg diag	93 deg diag	78 deg diag	86 deg diag	58 deg horiz	67.5 deg horiz
Video										
Image Sensor	1/2" CCD	1/2" CCD	1/2" Interline Transfer CCD	ICCD		CCD	1/2" CCD	1" SIT	1/3" CCD	1/3" CCD
Sensor Size	7.95mm horiz x 6.45mm vert									
# Pixels	811x508 (EIA) 795x696 (CCIR)	768x494 (EIA) 752x682 (CCIR)	768x494 (EIA) 752x682 (CCIR) EIA 0.0094mm horiz 0.0098mm vert				752x682 (oe1358) 768x494 (oe1359)			EIA 510 horiz x 492 vert
Pixel Spacing	0.0127mm									
Resolution	570 TV Lines	570 TV Lines	570 TV Lines (EIA) 560 TV Lines (CCIR)	500 TV Lines Horiz 250 TV Lines Vert	430 TV Lines	560 TV Lines	570 TV Lines	700 TV Lines	600 Lines	600 Lines
Scene Illumination	0.01 Lux @ 12.8	0.001 Lux @ f0.8	faceplate (useable display) 0.003 Lux faceplate (full resolution)		0.000E Lux Sensitivity 0.0001 Lux faceplate	0.0013 Lux Sensitivity faceplate	0.004 Lux Sensitivity faceplate	0.0002 Lux faceplate (Limiting) 0.001 Lux faceplate (Full Resolution)	0.003 Lux	0.003 Lux
Sig. to Noise	46dB (AGC off)	>46dB	46dB (AGC off)	45dB min	>40dB (AGC off)	>52 dB	>40dB	>40dB (AGC off)		
Video Output	1.0 V peak to peak @ 75 ohm	Composite, 1.0 V peak to peak	Composite	Composite, 1.0 V peak to peak	Composite, 1.0 V peak to peak	Composite, 1.0 V peak to peak	Composite, 1.0 V peak to peak	Composite, 1.0 V peak to peak	Composite	Composite
Video Format	EIA (RST70), CCIR	EIA, CCIR	EIA, CCIR	EIA, CCIR	EIA, CCIR	EIA, CCIR	EIA, CCIR	EIA, CCIR		
Scanning			525 Line/60Hz (EIA) 625 Line/50Hz (CCIR) 2:1 Interface		525 Lines @ 60Hz	525 Lines @ 60 Hz (EIA)	625 Lines @ 50Hz (CCIR) (oe1358) 525 Lines @ 60 Hz (EIA) (oe1359)	625 Lines @ 50Hz (CCIR) (oe1358) 525 Lines @ 60 Hz (EIA)		
Electrical										
Power	11-30 V DC	9-30 V DC	12-30 V DC	11-30 V DC	16-24 V DC	16-24 V DC	16-24 V DC	16-24 V DC		
Current	160 mA	160 mA	240mA max	900mA max	250mA max	250mA max	250mA max	675mA max		
Connector	Numerous	Numerous	Numerous	Numerous						
Bandwidth			30Hz to 8MHz							
Environmental										
Depth	300m/6000m	6000m/3000m	3000m std/6000m opt	1500m std	3000m	3000m	3000m	3000m std	500m	600m
Operating Temp.	-10 to +40 C	0 to +50 C	-10 to +50 C	-30 to +50 C	-5 to +40 C	-5 to +40 C	-5 to +40 C	-5 to +40 C		
Storage Temp.	-30 to +70 C	-20 to +60 C	-20 to +60 C	-35 to +60 C	-20 to +60 C	-20 to +60 C	-20 to +60 C	-20 to +60 C		
Price	2,470	4,290	6,710	22,500	27,125	8,670	3,420	22,670	1,085	10,662

8.3 Appendix 3: Camera Test Data

Air		
Video Files	Date (HST): 2/28/05	
Camera	Recording Device	Time (HST)
ROS Navigator	Viperfish Deep	13:25
ROS Navigator	Sony Camcorder	14:19
SOSI	Sony Camcorder	13:36
SOSI	Viperfish Deep	14:12
Sony	Viperfish Deep	13:49
Sony	Sony Camcorder	13:54
Straight Through Camera Resolution Test		
Room Lighting		
EIA Resolution Chart 1956		
Camera	Horizontal Lines Range	Vertical Lines Range
ROS	250 - 300	350 - 400
SOSI	200 - 250	200 - 250
Sony	225 - 275	350 - 400
Watec	200 - 250	175 - 225
Pier Testing		
All Camera Testing Done Side By Side with ROS Navigator		
Video Files	Date (HST): 4/13/05	
Camera	File:	
DSPL 1050	NOAA-20050413-104427-03.avi	
DSPL 2060	NOAA-20050413-105503-03.avi	
DSPL 5000	NOAA-20050413-102654-03.avi	
SOSI	NOAA-20050413-110912-03.avi	
Watec	NOAA-20050413-111856-03.avi	

8.4 Appendix 4: Botcam Prototype III Fact Sheet

Cost Per Unit: ~ \$38,000

Size and Weight:

External Dimensions of Frame (without bait arm): 48" x 22" x 18"

Bait Arm Length: 48"

Weight (in air): 150 lbs

Weight (in water): 10 lbs buoyant

Anchor Weight (in water): 100 lbs minimum

Recording Unit:

Viperfish Deep from Deep Development Corporation

Battery Life: ~ 4 hours recording with 2 camera's

Hard Drive: 80GB (~ 20 hours of stereo video)

Max Resolution: 720 x 486

Max Frame Rate: 30 frames per second

Input: Composite Video

Output: Digital Video

Depth Rating: 500 meters

Cameras:

Remote Ocean Systems (ROS) Navigator

1/2" CCD (charge-coupled device) sensor

3.4×10^{-4} lux faceplate sensitivity

Sensor Elements: 768 h x 494 v pixels

Depth Rating: 3,000 meters

Automation:

This system is capable of sitting dormant for up to one week. It can then automatically turn itself on, begin recording, release bait that is sealed to the environment, and turn itself off.

Stereo-Video:

The system is capable of supplying digital files that are readily imported into Vision Metrology Software (VMS) in order to make high precision, high accuracy measurements of flora and fauna that is recorded. Video synchronization is made possible by an external stereo sync device.

Major Subsystems:

Surface Signature including High Flyer, Mooring Ball, 2 Radio Beacons and Strobes, a Radar Reflector and Flag.

Acoustic Release for buoyant retrieval

Seabird 39 Temperature and Pressure Recorder

Automated Bait Release System

Video Capture including 2 Cameras and Electronics

Frame and Integrated Floatation

8.5 Appendix 5: Hardware, Software and Expendables

Subsystem	Item #	Component	Description	Vendor	Name	Phone/Fax	Email	Alt. Name/ Vendor(s)	Price	Unit	Quantity	Estimated Price
Video Capture	1	Video Capture Electronics	This device captures composite video, converts it to a digital format and stores it to a hard drive. The device also controls the remote triggering of a bat release signal. Unit includes cables for download and recharging.	Deep Development Corporation	Ken Bower, Tim McFarlane	Ph: 604-684-9871, Fx: 604-684-8472 www.deepdevelopmentcorp.com	kenb@deepdevelopment.com timc@deepdevelopment.com		\$7,995.00	ea	1	\$7,995.00
Video Capture	2	Camera	Low light sensitivity (0.001 Lux) CCD camera is waterproof. Focus range up to 6,000 meters.	Remot Ocean Systems	Brian Campers	Mobile: 1-616-884-1813, 1-866-556-8800 ext: 109, Fax: 1-866-556-8889 www.rosys.com	Brian@rosys.com	Corp Site Power and Light, Boat Stations	\$6,710.00	ea	2	\$13,420.00
Deploy and Recovery	3	Acoustic Release	This device is used to tie the buoyant frame system to an anchoring system. An acoustic signal sent from the back box (T70) triggers a ship triggered acoustic release to separate the frame from the anchor. The frame contains all the components to float freely in the surface.	Ocean Innovations	Brock Roseenthal	Tel: 656-454-4044, Fax: 656-454-5775 www.oceaninnov.com	brock@oceaninnov.com	Berthous, Scarifer Systems, Scandinavia, Norwegian Systems	\$1,320.00	ea	1	\$1,320.00
Data	4	Temperature and Pressure Sensor	A temperature and pressure sensor is added in order to give an accurate measure of how deep the unit is deployed along with a horizontal water velocity parameter.	Squad	Brian McCreilly	425-643-9866 / 425-643-9954 www.squadinc.com	Brian@SquadInc.com		\$1,734.00	ea	1	\$1,734.00
Gate Release	5	BWR Battery	13 AA NiMH rechargeable cells	Sexton Photographics LLC	Ken Sexton	503-371-6239 www.sextonphoto.com	ken@sextonphoto.com	Ocean Innovations, SSSI	\$388.00	ea	1	\$388.00
Gate Release	6	BWR Battery	13 AA NiMH rechargeable cells	Sexton Photographics LLC	Ken Sexton	503-371-6239 www.sextonphoto.com	ken@sextonphoto.com	Ocean Innovations, SSSI	\$65.00	ea	2	\$130.00
Gate Release	7	Bat Release	A 1.7 Liter Nipon bottle is used to contain bat until a signal is sent to a bat wire system.	Ocean Innovations	Brock Roseenthal	656-454-4044 / 656-454-5775 www.oceaninnov.com	brock@oceaninnov.com	General Instruments	\$336.00	ea	1	\$336.00
Gate Release	8	Bat Release Bat Wire	A custom built bat wire based on the Subsea Services system is used to trigger the bat release.	SSSI	Mike Bagley	(425) 656-1034 phone, (425) 669-5554 fax, (425) 669-8656 mobile www.sssi.com	mikeb@subsea.com	Subsea Services	\$335.00	ea	1	\$335.00
Video Capture	9	SVS	Stream Video Sync Device. This unit is used to synchronize the two video streams. This is necessary for time-photogrammetry.	Sexton Photographics LLC	Ken Sexton	503-371-6239 www.sextonphoto.com	ken@sextonphoto.com		\$389.00	ea	1	\$389.00
Frame	10	Synthetic Foam	Synthetic Foam is used as flotation for the system. The foam is placed at 24 1/2" intervals and modified as per drawings.	Fraxion Technologies	Brian Dallas	207-262-7149 www.fraxion.com	brian@fraxion.com	CCP	\$400.00	ea	2	\$800.00
Frame	11	3D/360° Farm Machining	Machining used to modify blocks	Universal Manufacturers	Taylor Hoag	808-845-5971 www.universal.com	info@universal.com	"Generic"	\$425.00	lot	1	\$425.00
Frame	12	Frame	Aluminum frame baked around 1-1/4" x 1/4" x 1/4" pipe. Pipe includes primer coating. See drawings for details. The frame was purchased separately and supplied to fabrication shop for integration with frame.	Universal Manufacturers	Taylor Hoag	808-845-5971 www.universal.com	info@universal.com	"Generic"	\$1,690.00	lot	1	\$1,690.00
Frame	13	Aluminum Connectors	2 1/4" x 2 1/4" x 1/4" thick aluminum channel was purchased separately and supplied to fabrication shop for integration with frame.	Wagner and Associates		414-214-0444 / 414-214-0450 www.wagnerandassociates.com/whs	info@wagnerandassociates.com	Royal Metals	\$7.30	ea	8	\$58.40
Frame	14	Aluminum Channel	1" leg x 1" wide x 1/8" thick aluminum channel was purchased separately and supplied to fabrication shop for integration with frame.	Royal Metals	Tucker	ph: 800-845-3222, fax: 808-841-1150 www.royalmetals.com	royalinfo@roy.com	"Generic"	\$36.45	ea	1	\$36.45
Frame	15	Aluminum Channel	1" leg x 2" wide x 1/8" thick aluminum channel was purchased separately and supplied to fabrication shop for integration with frame.	Royal Metals	Tucker	ph: 800-845-3222, fax: 808-841-1150 www.royalmetals.com	royalinfo@roy.com	"Generic"	\$36.00	ea	1	\$36.00
Frame	16	Aluminum Channel	2 1/4" x 2 1/4" x 1/4" thick aluminum channel was purchased separately and supplied to fabrication shop for integration with frame.	Royal Metals	Tucker	ph: 800-845-3222, fax: 808-841-1150 www.royalmetals.com	royalinfo@roy.com	"Generic"	\$3.45	ea	16	\$55.20
Frame	17	Delrin	4mm was purchased separately and supplied to fabrication shop for integration with frame. 3/8" x 2" x 1"	McMaster-Carr		ph: 800-852-6911, fax: 562-696-2923 www.mcmaster.com	bars@mcmaster.com	"Generic"	\$9.53	ea	0.33	\$3.14
Frame	18	Delrin	4mm was purchased separately and supplied to fabrication shop for integration with frame. 1" x 2" x 3"	McMaster-Carr		ph: 800-852-6911, fax: 562-696-2923 www.mcmaster.com	bars@mcmaster.com	"Generic"	\$21.88	ea	1.33	\$26.03
Frame	19	Delrin	4mm was purchased separately and supplied to fabrication shop for integration with frame. 3/4" x 2" x 2"	McMaster-Carr		ph: 800-852-6911, fax: 562-696-2923 www.mcmaster.com	bars@mcmaster.com	"Generic"	\$15.89	ea	1	\$15.89
Frame	20	Camera Mounts	3 1/2" Diameter Vibration Clamps for Camera Mounting	McMaster-Carr		ph: 800-852-6911, fax: 562-696-2923 www.mcmaster.com	bars@mcmaster.com	"Generic"	\$43.64	ea	4	\$174.56
Frame	21	Electricity Mounting U-Bolts	8 5/8" Diameter Stainless Steel Rubber Coated U-Bolts for mounting Viperfish Deep Unit to frame.	McMaster-Carr		ph: 800-852-6911, fax: 562-696-2923 www.mcmaster.com	bars@mcmaster.com	"Generic"	\$69.50	ea	2	\$139.00
Gate Release	22	BWR and S/G Hese Clamp	Quick Release Hese Clamps for BWR	McMaster-Carr		ph: 800-852-6911, fax: 562-696-2923 www.mcmaster.com	bars@mcmaster.com	"Generic"	\$31.24	ea	4	\$124.96
Gate Release	23	Bat Release Hese Clamp	Hese Clamp for Bat Release Nettle Bottle	Kidger		ph: 800-852-2501, fax: 800-852-2501 www.kidger.com	bars@mcmaster.com	"Generic"	\$8.00	ea	3	\$24.00
Gate Release	24	Acoustic Release Hese Clamp	Quick Release Hese Clamp for Acoustic Release Units	McMaster-Carr		ph: 800-852-2501, fax: 800-852-2501 www.mcmaster.com	bars@mcmaster.com	"Generic"	\$34.67	ea	2	\$69.34
Gate Release	25	BWR Bulkhead Connector 2 pin	Bulkhead connector for BWR ordered separately and shipped to Ken Sexton	Merco	Mike Chapman	425-798-4572 www.mercoinc.com	mcc@mercoinc.com	Ocean Innovations	\$29.13	ea	1	\$29.13

Subsystem	Item #	Component	Description	Model or Part #	Vendor	Name	Phone/Fax	Web Page	Email	Alternatives/Vendors/CO	Price	Unit	Quantity	Extended Price
Ball Release Video Camera	26	BWR Bulkhead Connector 3 pin	Bulkhead connectors for BWR infered separately and 3-pin cable to be used with Deep View Plugable cable.	MCBDM	Mecco	Mike Chapman	405-708-4572 609-654-4044 / 609-654-5775	www.meccocorp.com	mcco@meccocorp.com	Ocean Innovations	\$35.82	ea	1	\$35.82
Ball Release Video Camera	27	Camera Cable	BWR to Viewfind Deep View Plugable Cable. MCILEM + MCCLSF TO MCCLF + MCCLSF		Ocean Innovations	Eric Rosenthal	609-654-4044 / 609-654-5775	www.oceaninnov.com	eric@oceaninnov.com	Mecco	\$243.40		2	\$486.80
Ball Release Video Camera	28	BWR Cable	BWR to Viewfind Deep View Plugable Cable. MCILEM + MCCLSF TO MCCLF + MCCLSF		Ocean Innovations	Eric Rosenthal	609-654-4044 / 609-654-5775	www.oceaninnov.com	eric@oceaninnov.com	Mecco	\$172.10		1	\$172.10
Ball Release Video Camera	29	Bun Wire Pack Cable	BWR to Bun Wire View-Plugable Patch Cable		MECCO	Mike Chapman	425-788-4572	www.meccocorp.com	mcco@meccocorp.com	Ocean Innovations	\$61.15		1	\$61.15
Ball Release Video Camera	30	Camera Mounting Hardware	1/4" x 1/16" SS Nut, Bolt, 2x Neoprene Backed Washer 5/8" x 7/16" SS Nut, Bolt, 2x Neoprene Backed Washer, 2x Fender Washer		Kigops		ph. 800-832-2200 fx. 800-832-2201			"Generic"			2	\$0.00
Ball Release Video Camera	31	Synatic Foam Mounting Hardware	1/4" x 7" SS Bolt, 2x Nuts, 2x Fender Washers		Kigops		ph. 800-832-2200 fx. 800-832-2201			"Generic"			8	\$0.00
Ball Release Video Camera	32	Synatic Foam Mounting Hardware	1/4" x 7" SS Eye Bolt, 2x Nuts, 2x Fender Washers		Kigops		ph. 800-832-2200 fx. 800-832-2201			"Generic"			3	\$0.00
Ball Release Video Camera	33	Synatic Foam Eye Bolt	#10 x 1" SS Bolt, 2x Nuts, 1x Neoprene Backed Washer		Kigops		ph. 800-832-2200 fx. 800-832-2201			"Generic"			1	\$0.00
Ball Release Video Camera	34	Bun Wire Mounting Hardware	#10 x 1/16" SS Bolt, 2x Nuts, 2x Neoprene Backed Washer		Kigops		ph. 800-832-2200 fx. 800-832-2201			"Generic"			4	\$0.00
Ball Release Video Camera	35	Acoustic Release Mounting Hardware	Blue Steel Ring, 2x Neoprene Eye Bolts Spaced into 20" hole, 1 x 1/4" Conical Ring and 2x 1/4" Galvanized Shackles per Section		POD	Alex Waldin	808-478-8997		alex@pop-jama.com	"Generic"	\$35.31	lot	14	\$494.34
Ball Release Video Camera	36	Surface Line	Surface Line		Home Depot					"Generic"			1	\$0.00
Ball Release Video Camera	37	Line Storage Containers	Rubbermaid Heavy Duty 32 Gallon Galvalume Cans		Scientec	Adam Carson	800-252-4767 / 877-861-4143	www.scientec.com	adam@scientec.com		\$1,156.00	ea	1	\$1,156.00
Ball Release Video Camera	38	Radio Beacon and Strake	Warning Radio Beacon and Strake Light to Guide the Mower Operator to assist in deployment, reeling and recovery of Botcam	RF-700C1	Scientec	Adam Carson	800-252-4767 / 877-861-4143	www.scientec.com	adam@scientec.com		\$1,958.00	ea	1	\$1,958.00
Ball Release Video Camera	39	Radio Beacon and Strake	Warning Radio Beacon and Strake with Pressure Switch for submersible mounting near botcam frame in 58" diameter hole	RF-700C6	Scientec	Adam Carson	800-252-4767 / 877-861-4143	www.scientec.com	adam@scientec.com	"Generic"	\$205.60	lot	1	\$205.60
Ball Release Video Camera	40	High Flyer	Warning High Flyer for use in conjunction with 58" diameter hole		POD	Alex Waldin	808-478-8997		alex@pop-jama.com	"Generic"	\$191.75	ea	1	\$191.75
Ball Release Video Camera	41	Mooring Ball	Warning Mooring Ball for use in conjunction with 58" diameter hole	4403	POD	Alex Waldin	808-478-8997		alex@pop-jama.com	"Generic"	\$27.00	1/2 1/8" dia	1	\$27.00
Ball Release Video Camera	42	Top Harness	3-point lifting harness made from 3/8" blue steel wire with 1/4" shackles to connect to botcam top. Three lines rise at 3" diameter by 1/4" thick SS o-ring. O-ring attaches to 3-point lifting hardware		POD	Alex Waldin	808-478-8997		alex@pop-jama.com	"Generic"	\$27.00	1/2 1/8" dia	1	\$27.00
Ball Release Video Camera	43	Bottom Harness	3-point lifting harness made from 3/8" blue steel wire with 1/4" shackles to connect to botcam bottom. Three lines meet at 3" diameter by 1/4" thick o-ring. O-ring attaches to shackles and Acoustic Release		POD	Alex Waldin	808-478-8997		alex@pop-jama.com	"Generic"	\$27.00	1/2 1/8" dia	1	\$27.00
Ball Release Video Camera	44	SS O-rings	3 Point 1/4" Thick SS O-rings for 1 1/2" and 1 1/4" diameters		Kigops		ph. 800-832-2200 fx. 800-832-2201			"Generic"			3	\$0.00
Video Camera	T1	Temporary Auxiliary Can	Auxiliary Can is a temporary fix for automated lining mechanism. This is a product provided by Deep View. A 3-pin cable can be integrated into the Viewfind Deep Unit. Includes cable for communication to Viewfind Deep Unit.		Eric Development Corporation	Ken Shown, Tim McFarlane	Ph. 804-684-9271 Fx. 804-684-6772	www.ericdevelopment.com	ken@ericdevelopment.com tim@ericdevelopment.com		\$0.00	ea	1	\$0.00
Video Camera	T2	Auxiliary Can-Hose Clamps	Quick Release Hose Clamps for Auxiliary Can	S2TK12	McMaster-Carr		ph. 652-695-0911 fx. 652-695-2923	www.mcmaster.com	info@mcmaster.com	"Generic"	\$32.82	ea	2	\$65.64

Botcam Hardware and Components - These Items are Needed for Each Botcam System - page 2 of 2

Bitcram Hardware, Software and Components. These items are expandable and must be purchased as necessary.																	
Subsystem	Item #	Component	Description	Model or Part #	Vendor	Name	Phone/Fax	Web Page	Email	Alternative Vendor(s)	Price	Unit	Quantity	Extended Price	Number in Stock	Number Needed	Deficit
Various Deploy and Recover	E1	D-Cell Batteries	SVS 60, RF-7000C1 (4), RF-7000C (6)	D-cell						*Generic	\$0.00						0
	E2	C-Cell Batteries	Acoustic Release (8)	C-cell						*Generic							0
Data	E3	SV Batteries	Storage for External Hard Drives for more data storage at downloaded Videotape Video	9V						*Generic	\$0.00						0
	E4	DVD R's	Writable DVD Discs for long term archiving of 200 pounds of concrete are needed for each deployment. Minimum 2000 discs are needed.							*Generic	\$0.00						0
Deploy and Recover	E5	Concrete Anchors	Shoring, bracing and tie anchors. 20 lb per lb anchoring strength/1000 pounds. Minimum bracing strength/1000 pounds.							*Generic	\$0.00						0
	E6	Anchor Line	Expandable beam wires for bat release patterns. 80 lbs. minimum	LK-80	Subsea Sonics	Dave Breen				*Generic	\$6.00	ea		\$0.00	400	500	100
Various Deploy and Recover	E7	Bum Wires	200 lbs. minimum							*Generic							0
	E8	17' ea. zip ties	For various applications							*Generic							0
Various Deploy and Recover	E9	4' ea. zip ties	For various applications							*Generic							0
	E10	Bailing Wire	For latching shackles		POC	Adam Walden	888-478-9898		adam@pocsubsea.com	*Generic							0

Botcan Hardware, Software and Components - This list should be considered a minimum number of spare parts for up to 3 botcan units - Page 1 of 2

Subsystem	Item #	Component	Description	Model or Part #	Vendor	Name	Phone/Fax	Web Page	Email	Alternative Vendor(s)	Price	Unit	Quantity	Extended Price
Video Capture	2	Camera	Low light sensitivity (0.01 Lux) CCD camera in waterproof housing depth rated to 6,000 meters	Navigator	Remote Ocean Systems	Elio Campos	Mob: 1619 884 1613 Office: 1 866 595 5800 ext. 106, Fax: 1 866 595 8808	www.rso.com	elio@rso.com	Deep Sea Power and Light Cameras Solutions	\$6,710.00	ea	2	\$13,420.00
Deploy and Recovery	3	Acoustic Release	This device is used to tie the buoy at the system to an archiving system. An acoustic signal sent from the botcan will indicate a signal triggers the acoustic release and the buoy is released. The buoy contains all the components to float freely to the surface.	(MSEA-AR70)	Ocean Innovations	Erick Rosenthal	Tel: 866-454-4044, Fax: 866-454-5775	www.oceaninnovations.com	erick@oceaninnovations.com	Beribus Scubaor Systems, Inc Ocean Systems	\$3,220.00	ea	1	\$3,220.00
Data	4	Temperature and Pressure Sensor	A temperature and pressure sensor is needed in order to give an accurate measure of how deep the unit is deployed along with a fundamental water quality parameter.	SBE 39	Seabird	Brian McCully	425-543-9866 / 425-613-9554	www.seabird.com	seabird@seabird.com	Ocean Innovations	\$1,734.00	ea	1	\$1,734.00
Bat Release	5	BWP	Bum Wire Relay	BWR	Seaton Photographic LLC	Ken Sevton	503-371-6229	www.seatonphoto.com	seaton@seatonphoto.com	Ocean Innovations, SPSI	\$389.00	ea	1	\$389.00
Bat Release	6	BWP Battery	13 AA Ni-Mn rechargeable cells	BWR1	Seaton Photographic LLC	Ken Sevton	503-371-6229	www.seatonphoto.com	seaton@seatonphoto.com	Ocean Innovations, SPSI	\$65.00	ea	2	\$130.00
Bat Release	7	Bat Release	A 1.7 liter Nisk bottle is used to contain a bat until a signal is sent to a turn wire system.	110-1.7	Ocean Innovations	Erick Rosenthal	866-454-4044 / 866-454-5775	www.oceaninnovations.com	erick@oceaninnovations.com	General Oceanographics, Wildco	\$335.00	ea	1	\$335.00
Bat Release	8	Bat Release Bum Wire	A custom built bum wire based on the Subsea Services system is used to trigger the bat release.	Bum Wire	SOSI	Mica Begley	(425)865-1634 phone, (425)865-5554 fax, (425)538-8885 mobile	www.sosiphoto.com	mica@sosiphoto.com	Subsea Services	\$355.00	ea	1	\$355.00
Video Capture	9	SVS	Strobe Video Sync Device. This unit is used to synchronize video streams. This is necessary for stereo photography.	SVS	Seaton Photographic LLC	Ken Sevton	503-371-6229	www.seatonphoto.com	seaton@seatonphoto.com	Ocean Innovations	\$389.00	ea	1	\$389.00
Frame	20	Camera Mounts	3.5" Diameter Vibration Clamps for Camera Mounting	3055749	McVaster-Carr	Ken Sevton	ph: 808-632-2200 fax: 808-632-2201	www.mcvaster.com	seaton@seatonphoto.com	"Generic"	\$43.64	ea	2	\$87.28
Frame	22	BWP and SVS Hose Clamp	Hose Clamp for Bat Release Nisk Bottle	521W12	McVaster-Carr	Ken Sevton	ph: 808-632-2200 fax: 808-632-2201	www.mcvaster.com	seaton@seatonphoto.com	"Generic"	\$31.24	ea	2	\$62.48
Bat Release	23	Bat Release Hose Clamp	Quick Release Hose Clamp for BWP		Kilgus		ph: 808-632-2200 fax: 808-632-2201	www.kilgus.com	seaton@seatonphoto.com	"Generic"	\$34.67	ea	2	\$69.34
Frame	24	Acoustic Release Hose Clamp	Quick Release Hose Clamp for Acoustic Release when deployed	5215K14	McVaster-Carr	Ken Sevton	ph: 808-632-2200 fax: 808-632-2201	www.mcvaster.com	seaton@seatonphoto.com	Ocean Innovations	\$29.13	ea	1	\$29.13
Bat Release	25	BWP Bulkhead Connector 2	Bulkhead connectors for BWP cables deployed separately and supplied to Ken Sevton.	MCBQM	Mecco	Mike Chaprin	425 788 4522	www.mecco.com	mecco@mecco.com	Ocean Innovations	\$35.02	ea	1	\$35.02
Bat Release	26	BWP Bulkhead Connector 3	Bulkhead connectors for BWP cables deployed separately and supplied to Ken Sevton.	MCBQM	Mecco	Mike Chaprin	425 788 4522	www.mecco.com	mecco@mecco.com	Ocean Innovations	\$243.40	ea	2	\$486.80
Video Capture	27	Camera Cable	ROS Navigator to Vaeastik Deep Wet-Pluggable Cable		Ocean Innovations	Erick Rosenthal	866-454-4044 / 866-454-5775	www.oceaninnovations.com	erick@oceaninnovations.com	Mecco	\$172.10	ea	1	\$172.10
Bat Release	28	Bum Wire Patch Cable	BWP to Vaeastik Deep Wet-Pluggable Cable - MCL5M - MCL5P TO MCL5P - MCL5P TO MCL5P		Ocean Innovations	Erick Rosenthal	866-454-4044 / 866-454-5775	www.oceaninnovations.com	erick@oceaninnovations.com	Mecco	\$61.15	ea	1	\$61.15
Frame	30	Camera Mounting Hardware	Wet to BWP Deep Wet-Pluggable Patch Cable Washer		MECCO	Mike Chaprin	ph: 808-632-2200 fax: 808-632-2201	www.mecco.com	mecco@mecco.com	Ocean Innovations	\$0.00	ea	2	\$0.00
Deploy and Recover	32	Synthetic Foam Mounting Hardware	14" x 7" SS Bolt, 2x Nuts, 2x Fender Washers		Kilgus	Adrian Washburn	808-476-8997		adrian@kilgus.com	"Generic"	\$35.31	lot	14	\$494.34
Deploy and Recover	33	Synthetic Foam Mounting Hardware	14" x 7" SS Eye Bolt, 2x Nuts, 2x Fender Washers		Kilgus	Adrian Washburn	808-476-8997		adrian@kilgus.com	"Generic"	\$1,165.00	ea	1	\$1,165.00
Frame	35	Acoustic Release Mounting Hardware	#10 x 1/2" SS Bolt, 2x Nuts, 2x Neoprene Backed Washers		Kilgus	Adrian Washburn	808-476-8997		adrian@kilgus.com	"Generic"	\$0.00	ea	4	\$0.00
Deploy and Recover	36	Surface Light	36" Super Shot Rope, Galvanized Eye Bolt Silled and 2x 1/2" Galvanized Steel and 2x 1/2" Galvanized Shackles for Surface Light		POP	Adrian Washburn	808-476-8997		adrian@kilgus.com	"Generic"	\$35.31	lot	14	\$494.34
Deploy and Recover	36	Radio Beacon and Strobe	Waterproof Radio Beacon and Strobe Light for Surface Light in Mounting to assist in deployment, tracking and recovery of Botcan.	RF-700C1	Saimac	Adam Cameron	800-225-767 / 877-581-4143	www.saimac.com	adam@seatonphoto.com	Ocean Innovations	\$1,165.00	ea	1	\$1,165.00
Deploy and Recover	39	Radio Beacon and Strobe	Waterproof Radio Beacon and Strobe with Pressure Switch for submersible mounting near botcan frame in case line parts.	RF-700C5	Saimac	Adam Cameron	800-225-767 / 877-581-4143	www.saimac.com	adam@seatonphoto.com	Ocean Innovations	\$1,559.00	ea	1	\$1,559.00
Deploy and Recover	40	High Flyer	15 Aluminum Pole with Radar Reflector, Orange Flag, 2 Conduits, 2x 1/2" Galvanized Steel and Eye Bolt, 2x Surface Mounting Hardware for time to help mark the location of deployed Botcan.		POP	Adrian Washburn	808-476-8997		adrian@kilgus.com	"Generic"	\$205.60	lot	1	\$205.60

Botcan Hardware, Software and Components - This list should be considered a minimum number of spare parts for up to 3 Botcan units - Page 2 of 2

Subsystem	Item #	Component	Description	Model or Part #	Vendor	Name	Phone/Fax	Email/Web Page	Email	Alternation Vendor(s)	Price	Unit	Quantity	Estimate Price
Deploy and Recover	41	Moving Ball	24" Diameter Moving Ball for use in conjunction with surface signature. This ball will assist recovery by providing for a good surface line to throw a grapple hook on as well as provide for full Botcan and snobar flotation in case the entire unit falls or is dragged off a ship's deck into blue water.	4403	PQP	Aden Walston	808-473-8897		adk@pqc.hawaii.gov	"Generic	\$191.75	ea	1	\$191.75
Frame	42	Top Harness	3-point harness made from 3/8" dia steel line with 1/2" shackles to connect to botcan top. Three lines meet at 3" diameter by 1/2" thick SS o-ring. O-ring attaches to syntactic blocks and then surface line.		PQP	Aden Walston	808-473-8897		adk@pqc.hawaii.gov	"Generic	\$27.00	1/2 spool	1	\$27.00
Frame	43	Bottom Harness	3-point harness made from 3/8" dia steel line with 1/2" shackles to connect to botcan bottom. Three lines meet at 3" diameter by 1/2" thick o-ring. O-ring attaches to shackle and float.		PQP	Aden Walston	808-473-8897		adk@pqc.hawaii.gov	"Generic	\$27.00	1/2 spool	1	\$27.00
Frame	44	SS O-rings	3" Diameter x 1/4" Thick SS O-rings for top and bottom harness rigging.		Kalgees		PH: 808-833-3200, fax: 808-833-5281			"Generic			3	\$0.00

Subsystem	Item #	Component	Description	Model or Part #	Vendor	Name	Phone/Fax	Web Page	Email	Alternative Vendor(s)	Price	Unit	Quantity	Entered Price
Deploy and Recover	S1	Acoustic Release Deck Box	Acoustic Release Deck Box and Transducer	RSEA TT70	Ocean Innovations	Erick Rosenthal	658-764-0644 / 658-454-5775	www.oceaninnovations.com	erick@oceaninnovations.com	Benthos	\$2,745.00	ea	1	\$2,745.00
Deploy and Recover	S2	Radio Beacon Locator	Radio Beacon Locating Device. Allows the Seimac Radio Beacon Frequencies to be located by both visual and audio cues. Indicates both direction and strength of signal.	DF-500N	Seimac	Adam Cameron	800-226-4767 / 677-891-4143	www.seimac.com	acameron@seimac.com		\$1,560.00	ea	1	\$1,560.00
Data	S3	Laptop	Laptop computer with VMS software, Viperfish Viewer, Windows Media Player and Seabird S1000 installed. Also must be able to communicate via a 5-pin serial port and an ethernet connector. Also need crossover cable for communications with Viperfish Deep.	Latitude D810	Dell			www.dell.com		*Generic	\$1,977.55	ea	1	\$1,977.55
Site Release	S4	BVS Battery Charger and Battery	BVS Battery Charger and spare battery for factum	BVVR Charger	Sexton Photographic LLC	Ken Sexton	503-371-6239	www.sextonphoto.com	ken@sextonphoto.com		\$72.00	ea	1	\$72.00
Data	S5	VMS Software	VMS Measurement Software for stereo-video measurements.	VMS	Geomsoft	Mark Shorff	614-160-9589	www.geomsoft.com	mark@geomsoft.com		\$3,900.00	site lic	1	\$3,900.00
Data	S6	Calibration Cable	Black anodized aluminum calibration cable for stereo-video calibrations.	Calibration Cable		Evan Hisey	616-665-2415		evan@hisey.com				1	\$0.00

Bottom Hardware, Software and Components - These items are one-time purchases needed for any group of wetcams

8.6 Appendix 6: Frame Design Drawings

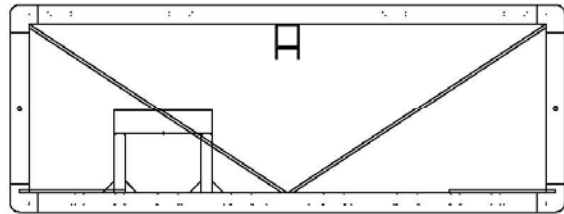
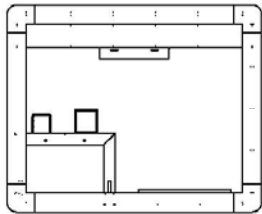
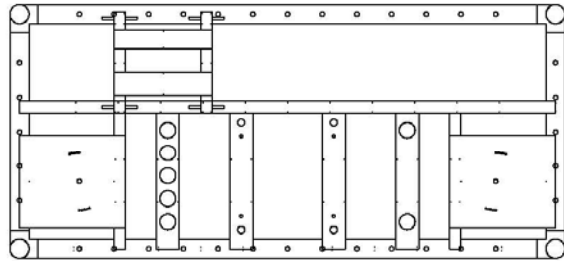
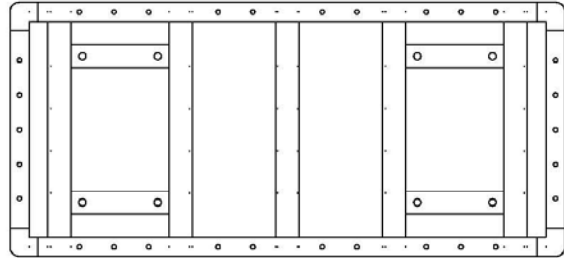

BOTCAM III FRAME
OVERALL LAYOUT
ALL MATERIALS ALUMINUM UNLESS NOTED

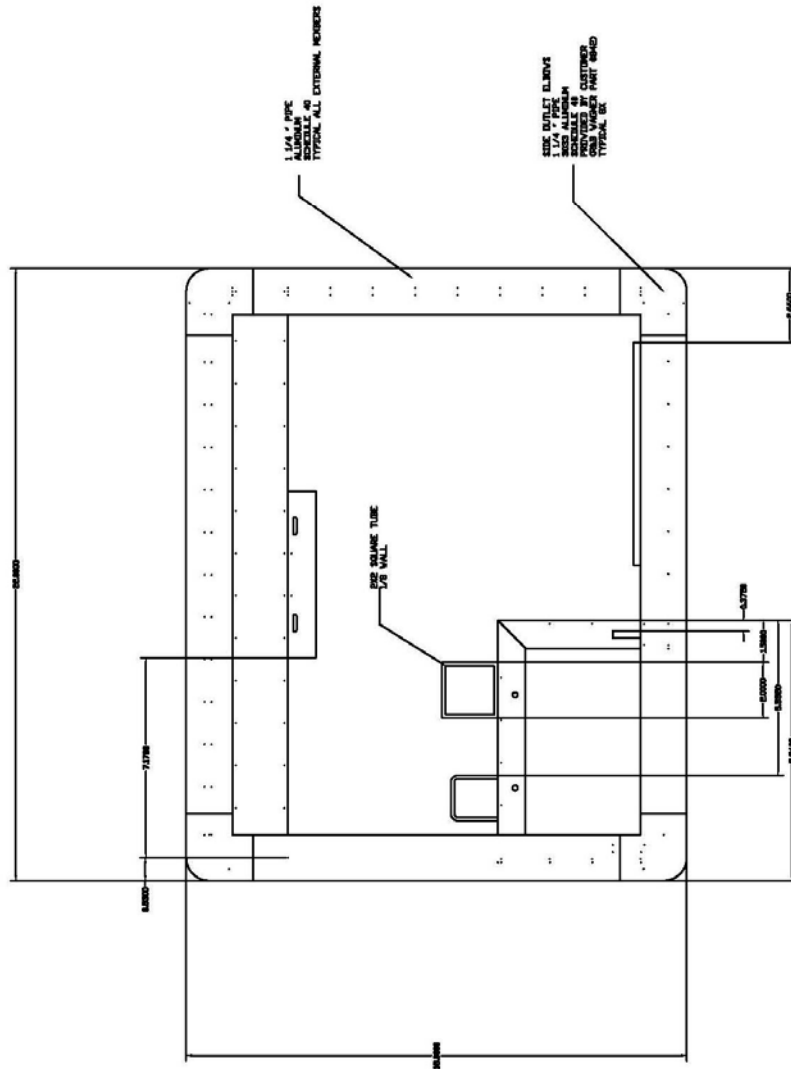

BOTCAM III FRAME
FRAME SIDE

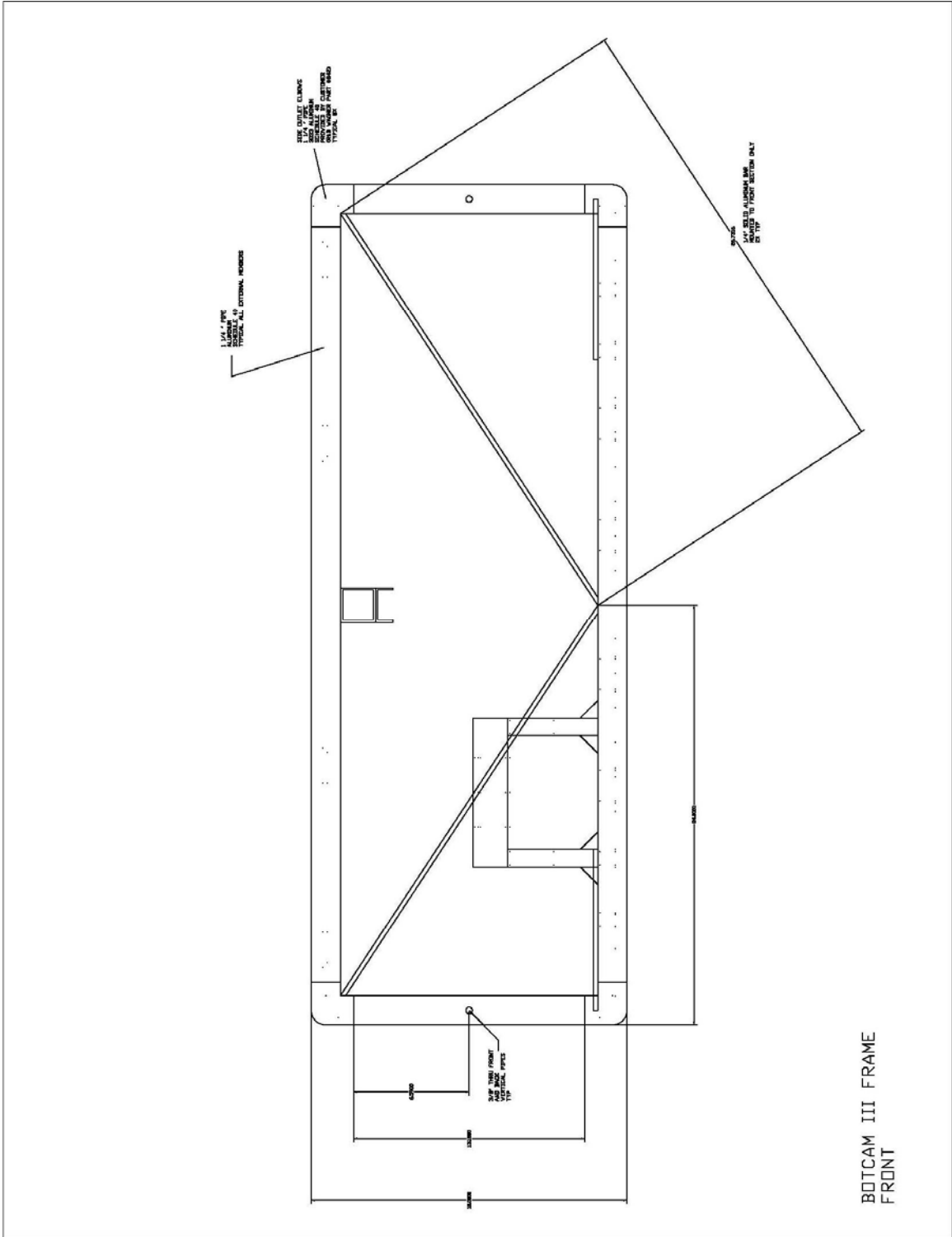

BOTCAM III FRAME
FRONT

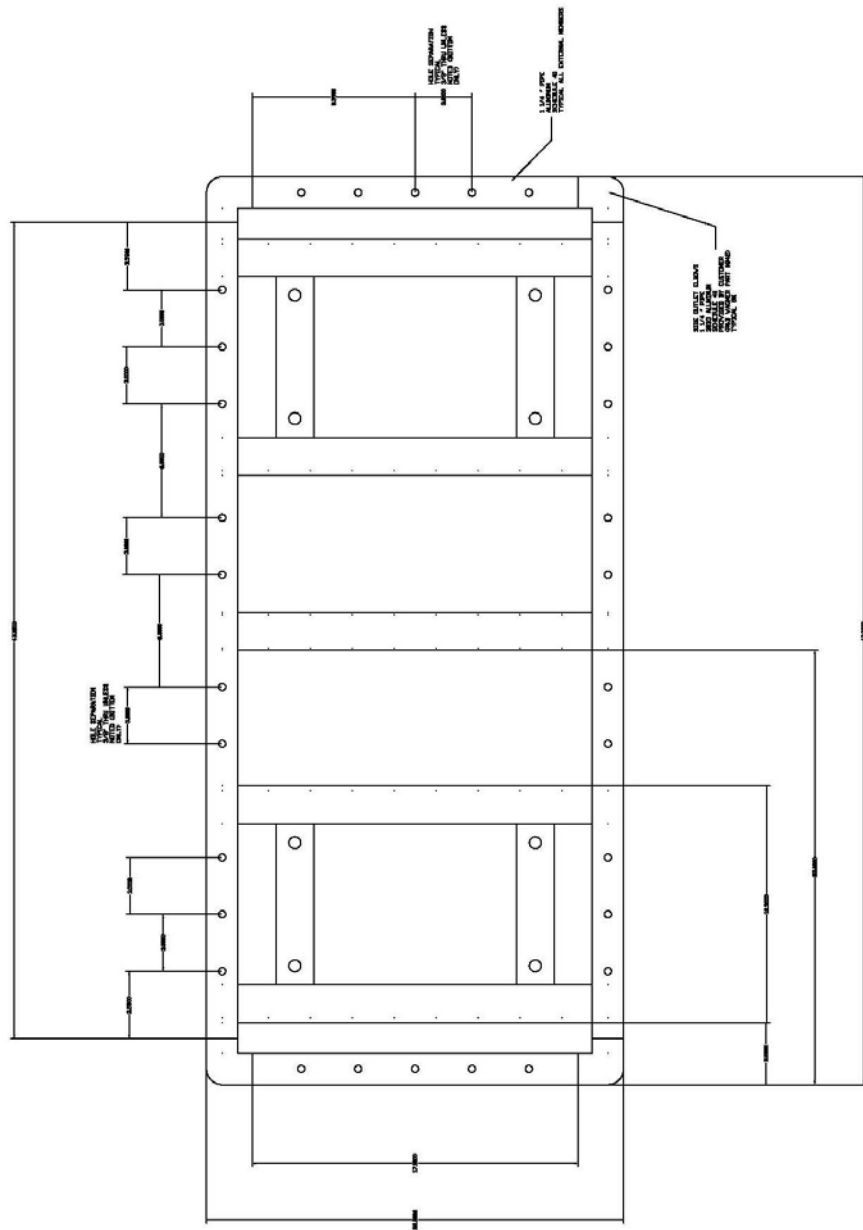

BOTCAM III FRAME
SECTION B-B

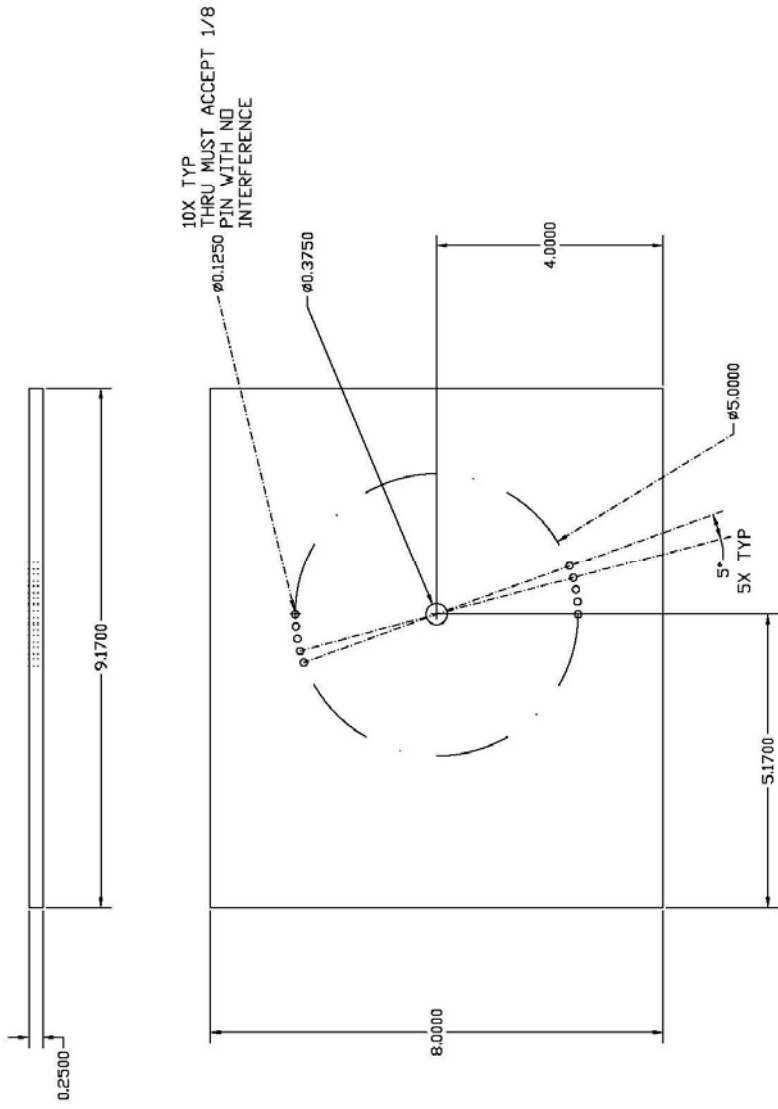

BOTCAM III FRAME
 CAMERA WELD PLATE
 PART # 1
 QUANTITY: 2

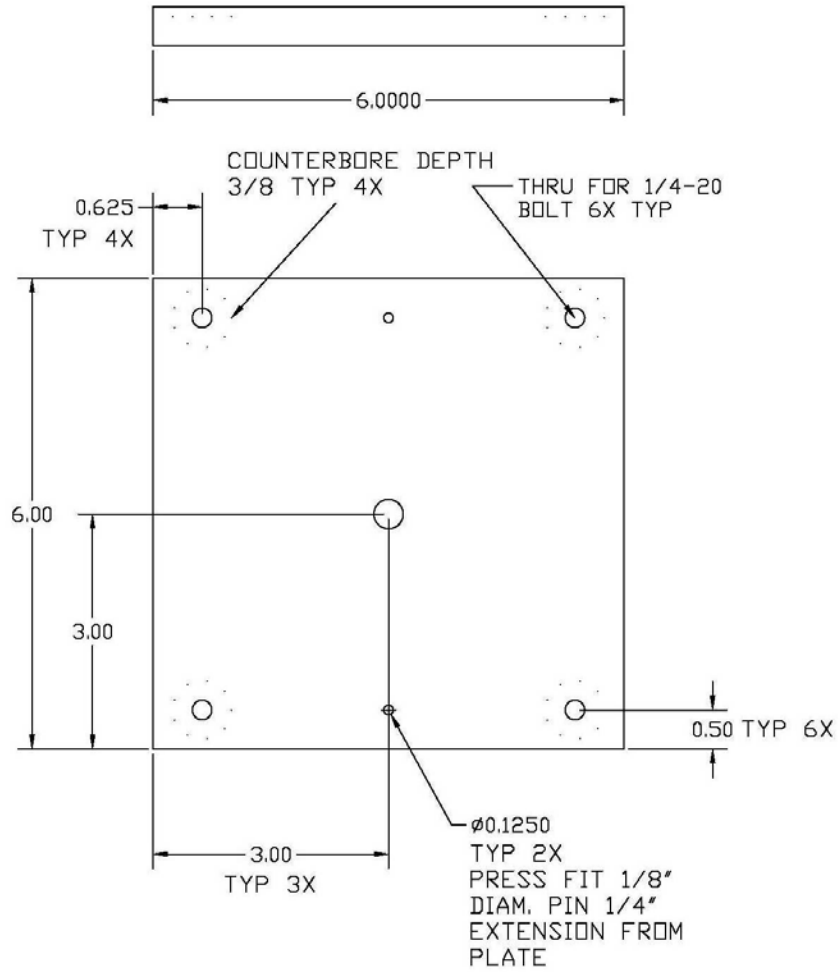

BOVCAM III FRAME
CAMERA MOUNT PLATE
PART # 2
QUANTITY: 2

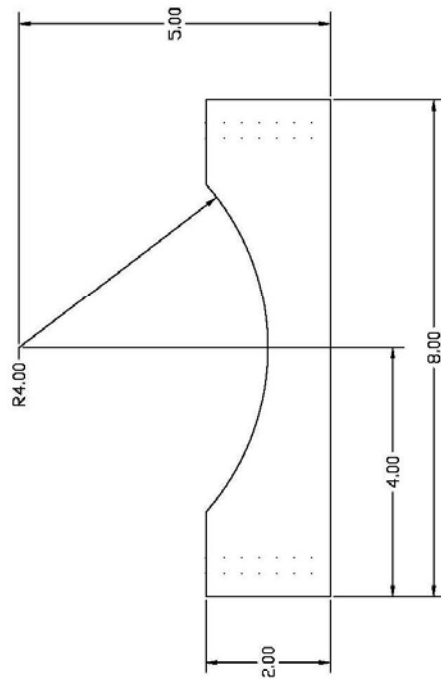

MATERIAL: DELRIN

BOTCAM III FRAME
VIPERFISH MOUNTS
PART # 3
QUANTITY: 2

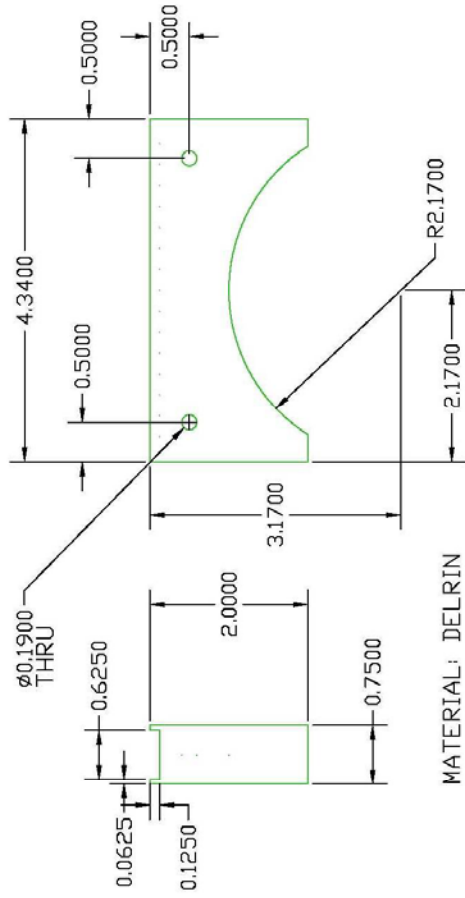

BOTCAM III FRAME
 ACOUSTIC RELEASE MOUNT
 PART # 4
 QUANTITY: 2

2X1 CHANNEL
1/8" THICKNESS

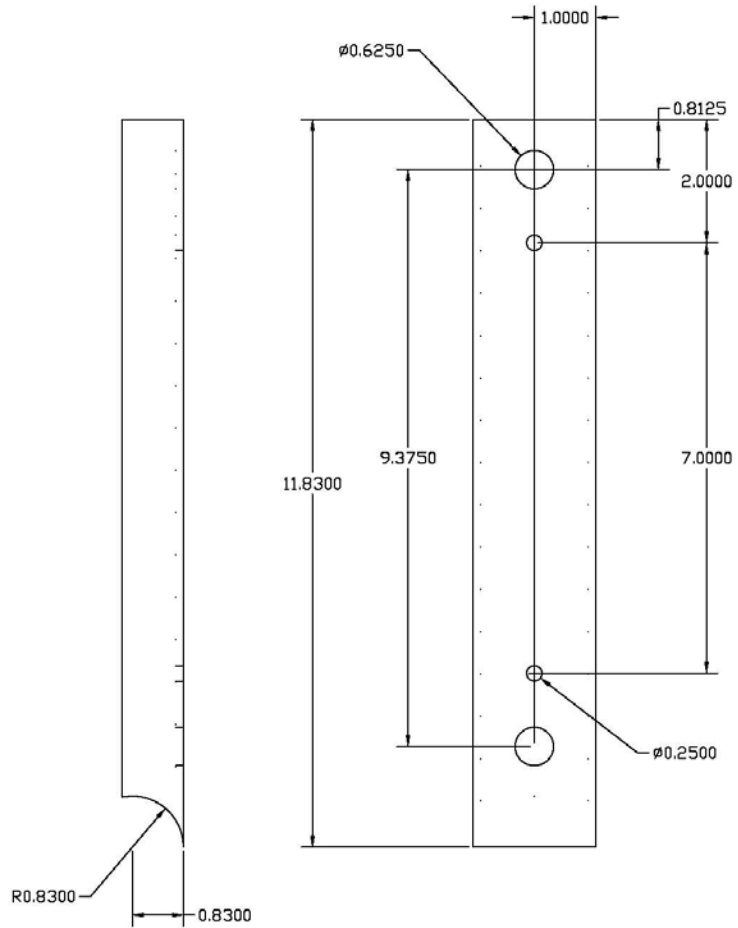
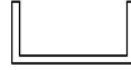

BOTCAM III FRAME
VIPERFISH CROSS BAR MOUNT
PART # 5
QUANTITY: 2



2X1 CHANNEL
1/8" THICKNESS

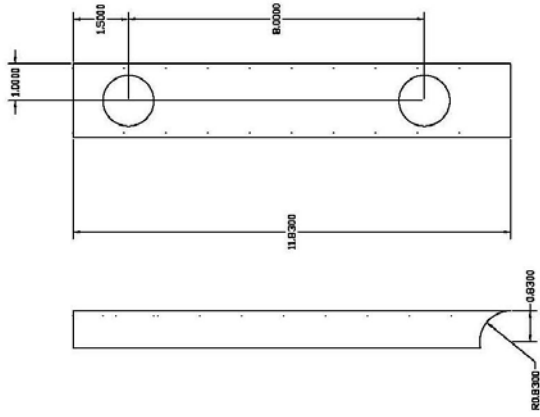

2X1 CHANNEL
1/8" THICKNESS

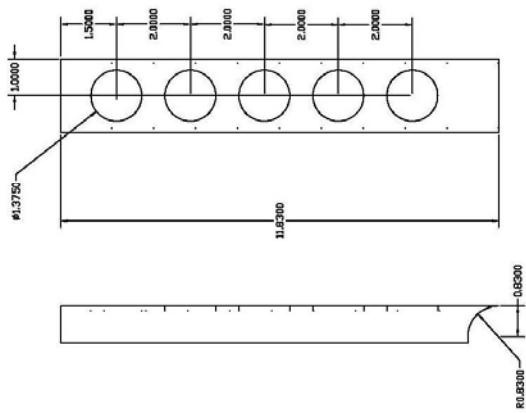

BOTCAM III FRAME
2 INCH CROSS MOUNTS
PART # 6 AND 7
QUANTITY: 1 EACH

1X1 CHANNEL
1/8" THICKNESS

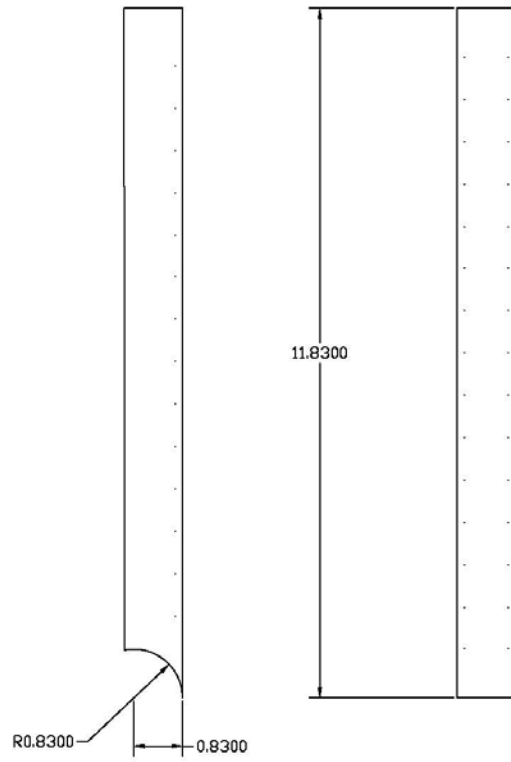

BOTCAM III FRAME
1 INCH CROSS MOUNT
PART # 8
QUANTITY: 2

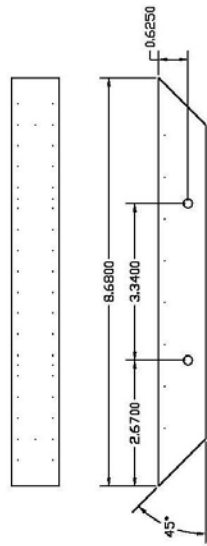

1X1 CHANNEL
1/8 THICKNESS

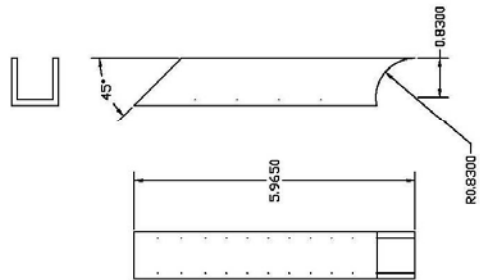
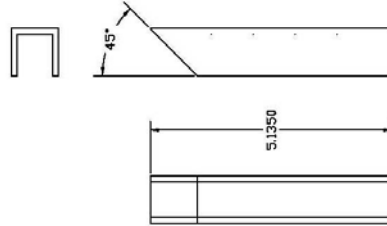

BITCAM, III FRAME
REAR STORAGE MOUNTS
PART # 9
QUANTITY: 1 EACH

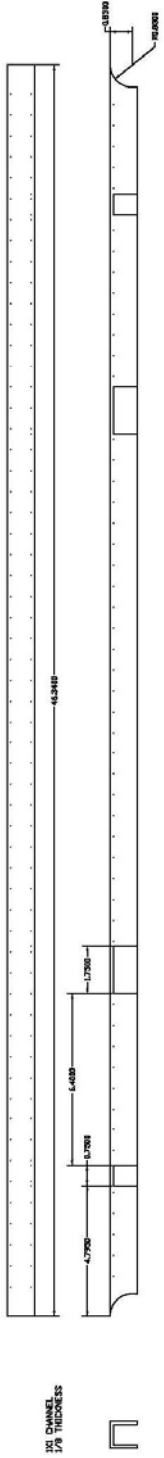

BOTCAM III FRAME
 LONG CROSS MEMBER
 PART # 10
 QUANTITY: 1

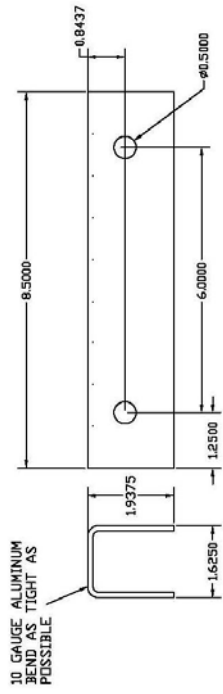

BOTCAM III FRAME
 BAIT ARM STORAGE MOUNT
 PART # 11
 QUANTITY: 1

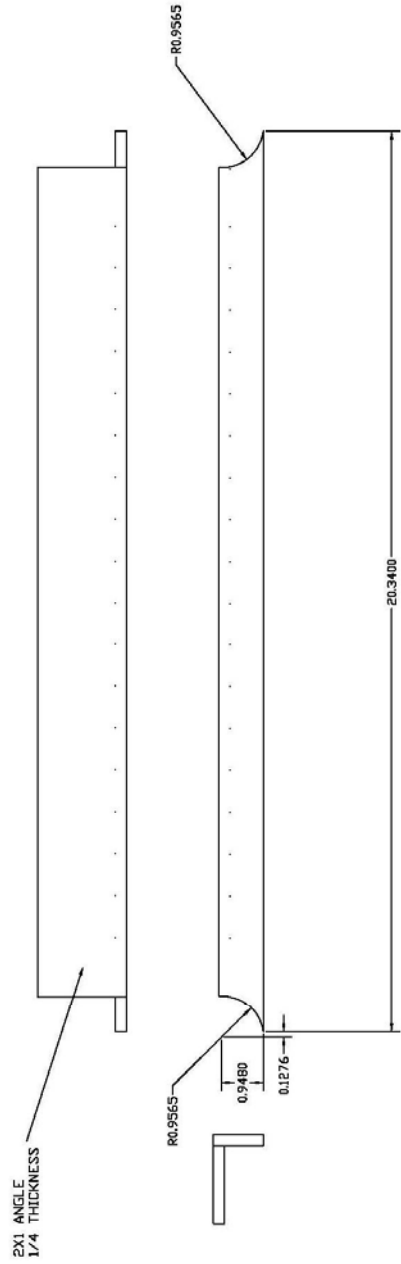

BOTCAM III FRAME
 SYNTECTIC MOUNTS
 PART # 12
 QUANTITY: 4

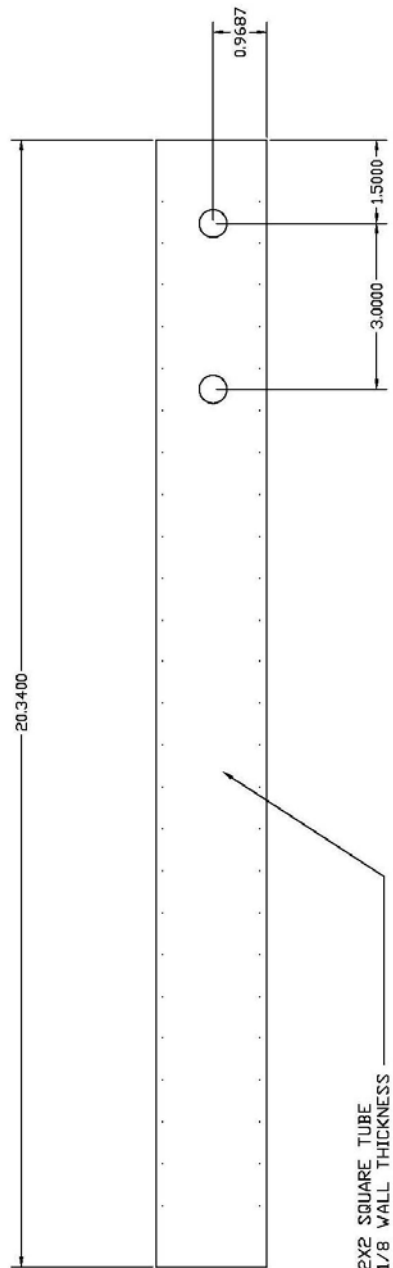

BOTCAM III FRAME
 BAIT ARM FRAME MOUNT
 PART # 13
 QUANTITY: 1

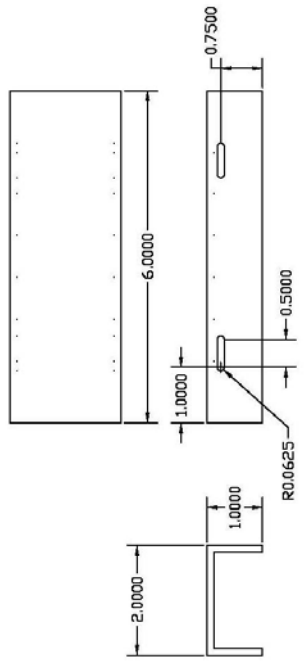

BOTCAM III FRAME
 SEABIRD 39 MOUNT
 PART # 14
 QUANTITY: 1

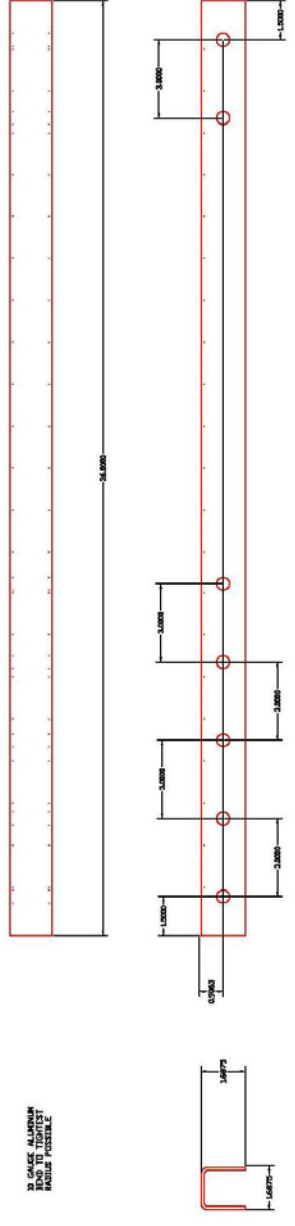

BOTCAM III FRAME
 BAIT ARM SECTION 1
 PART # 15
 QUANTITY: 2

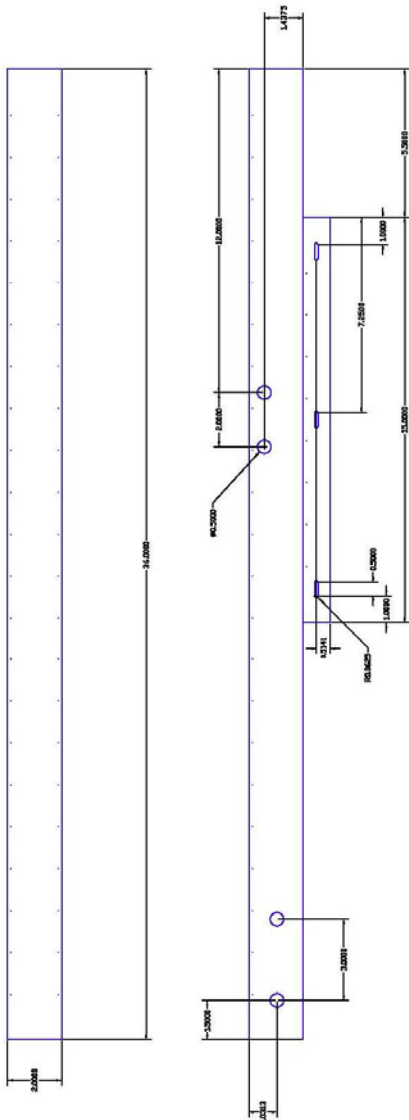

SEE CHANNEL THICKNESS APPLIED TO END THICKNESS OF WALL



BOTCAM III FRAME
 BAIT ARM SECTION 2
 PART # 16
 QUANTITY: 2

1/2 SOLID ALUM BAR

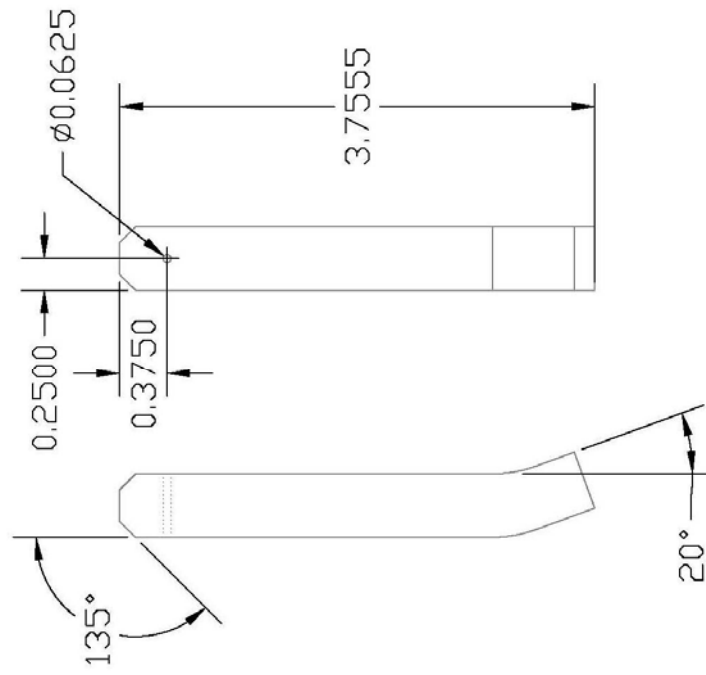

BOTCAM III FRAME
PIN
PART # 17
QUANTITY: 8

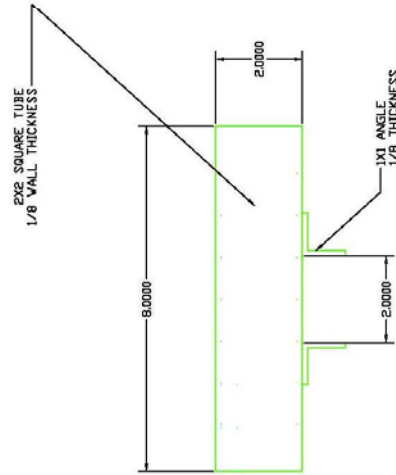
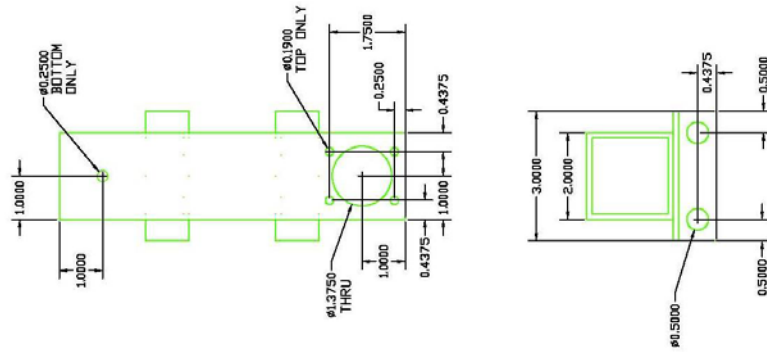

BOTCAM III FRAME
 BURN WIRE MOUNT
 PART # 18
 QUANTITY: 2

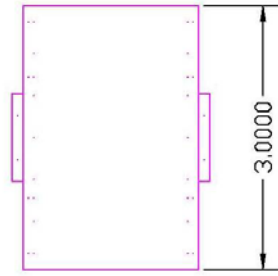

1 X 1/8 FLAT BAR
 WELDED TO 2X1 CHANNEL
 1/8 THICK

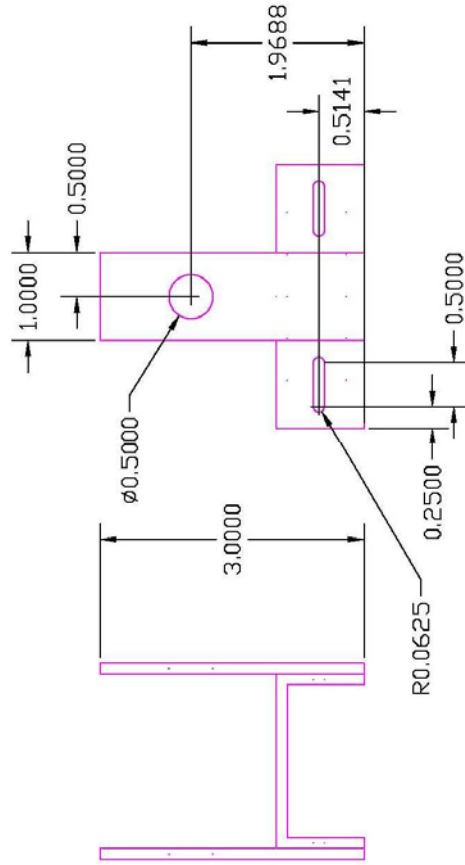

BOTCAM III FRAME
 SVS MOUNT
 PART # 19
 QUANTITY: 2

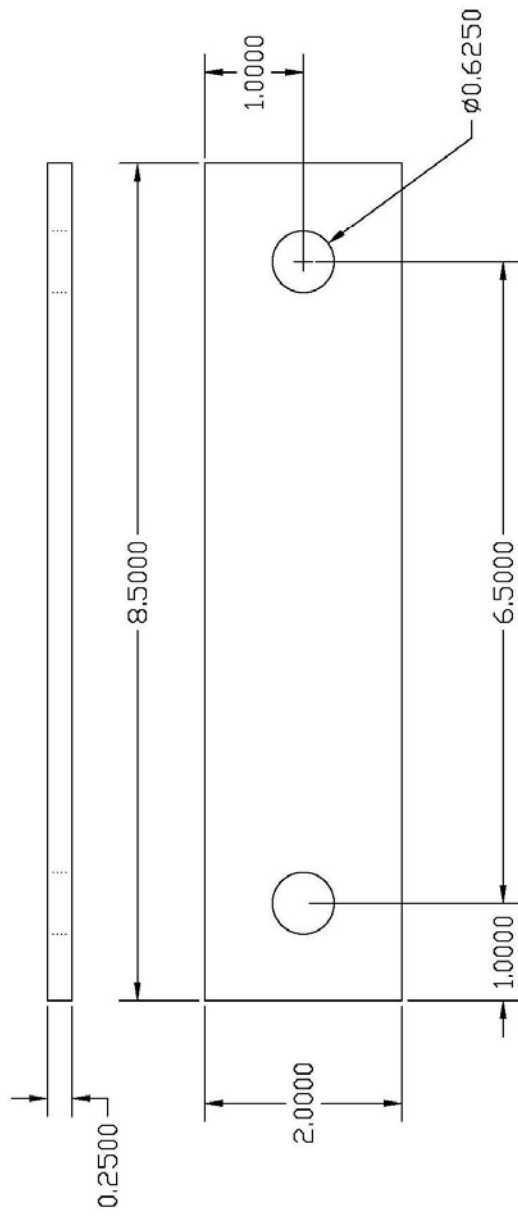

BOTCAM III FRAME
FOAM MOUNTS
PART # 20
QUANTITY: 4

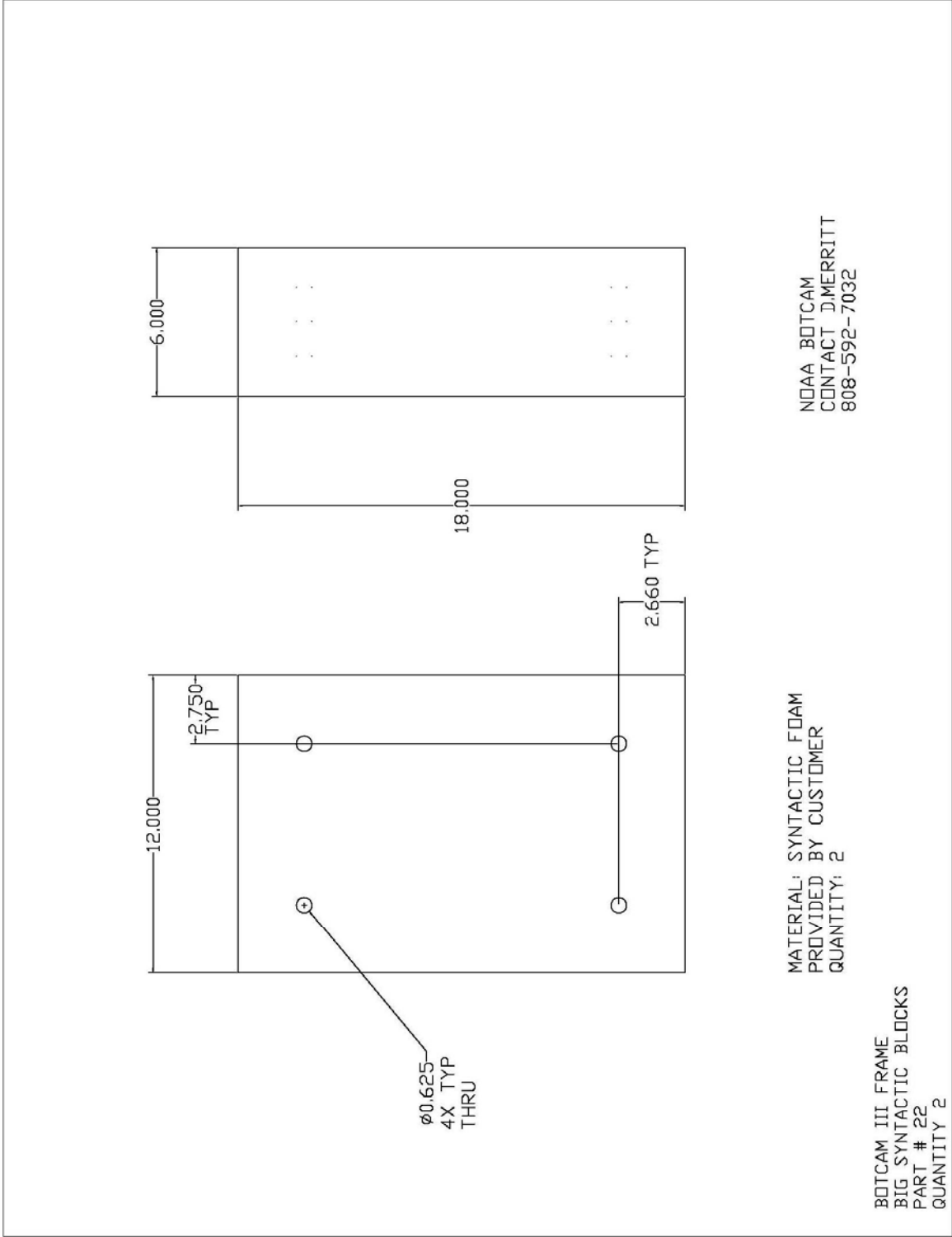

NDA4 BOTCAM
CONTACT DIMERRITT
808-592-7032

MATERIAL: SYNTHACTIC FOAM
PROVIDED BY CUSTOMER
QUANTITY: 2

BOTCAM III FRAME
BIG SYNTHACTIC BLOCKS
PART # 22
QUANTITY 2

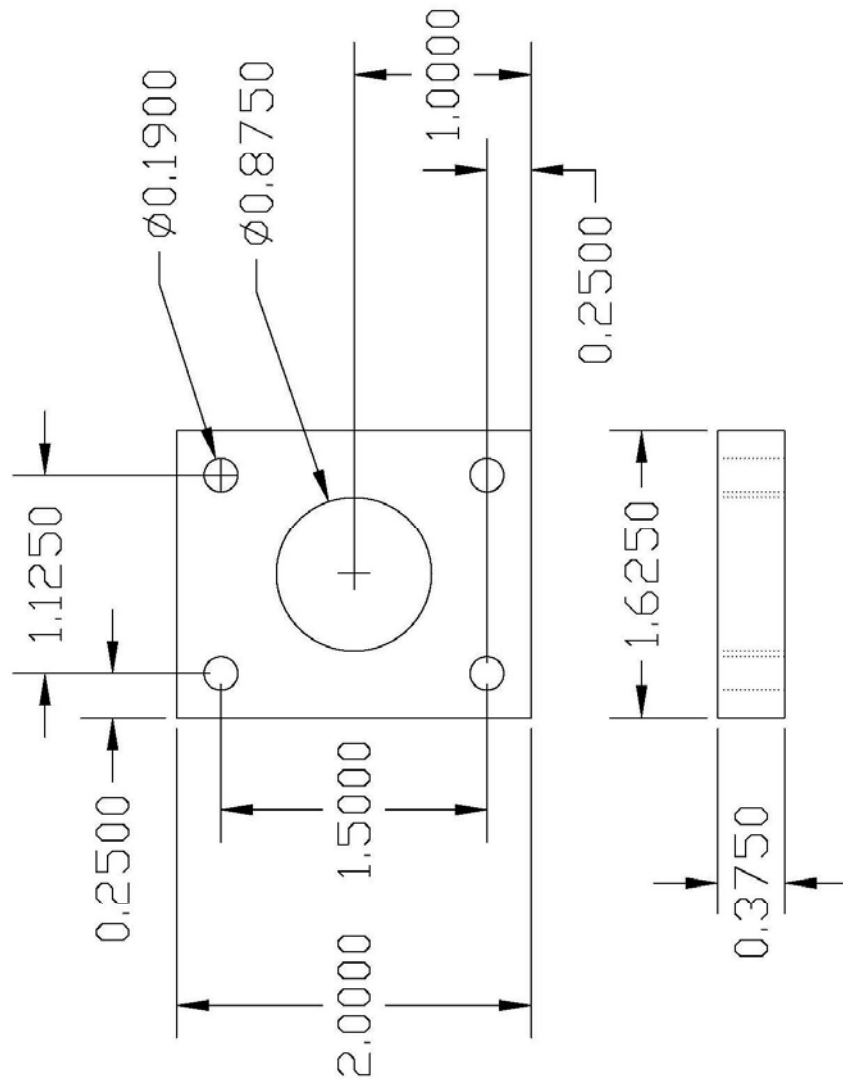

BOTCAM III FRAME
 BURN WIRE BLOCK
 PART # 21
 QUANTITY: 2

MATERIAL: DELRIN

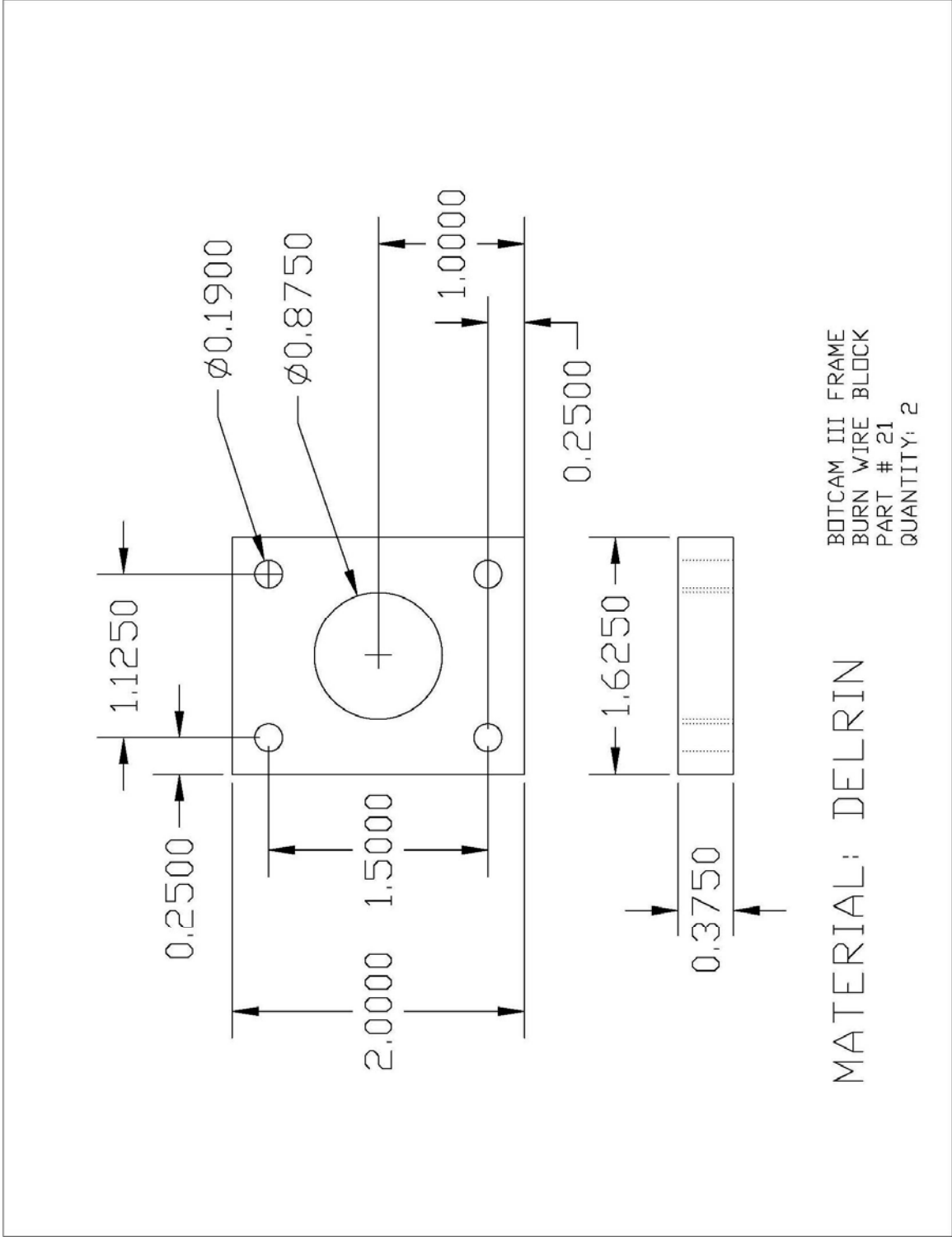

BOTCAM III FRAME
 BURN WIRE BLOCK
 PART # 21
 QUANTITY: 2

MATERIAL: DELRIN

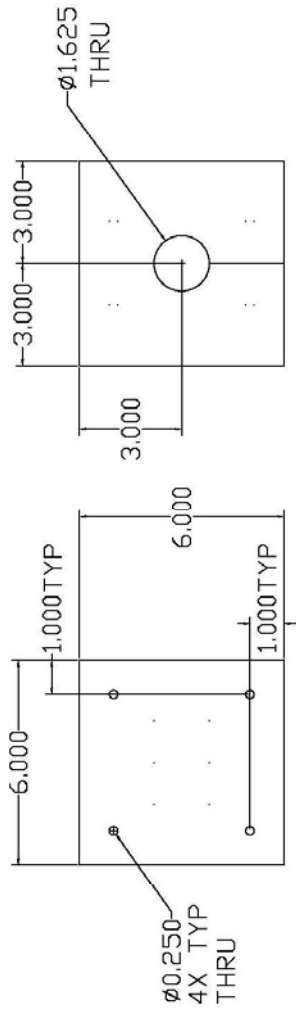

MATERIAL: SYNTACTIC FOAM
 PROVIDED BY CUSTOMER
 QUANTITY: 1

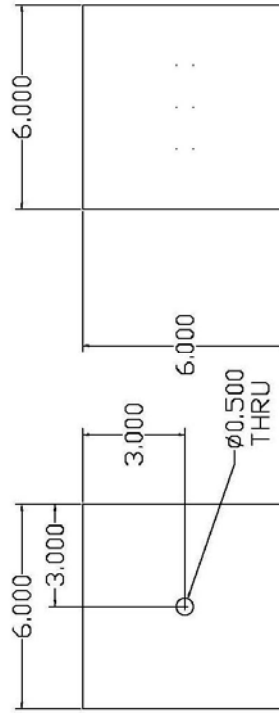

MATERIAL: SYNTACTIC FOAM
 PROVIDED BY CUSTOMER
 QUANTITY: 3

BOTCAM III FRAME
 OVERALL LAYOUT
 PART # 23

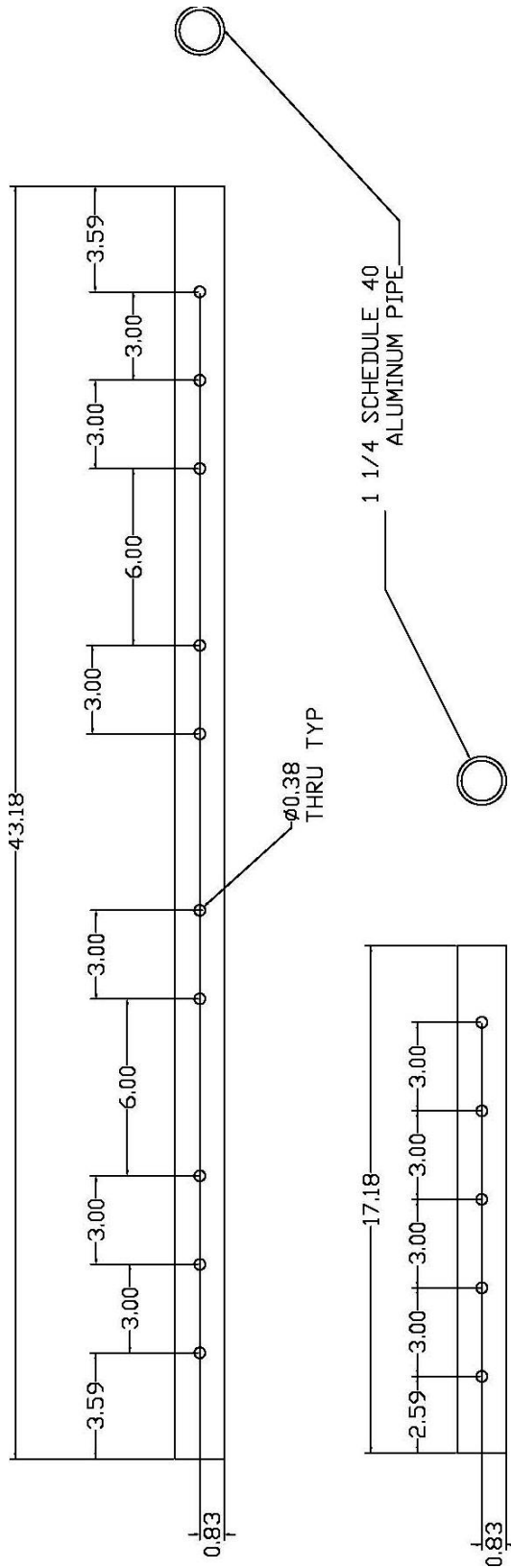

NOAA BOTCAM FRAME
 1 1/4 PIPE
 2X EACH PIECE
 SECTION B-B

BOTCAM III FRAME
 TUBING SECTION B-B
 PART # 24 AND 25

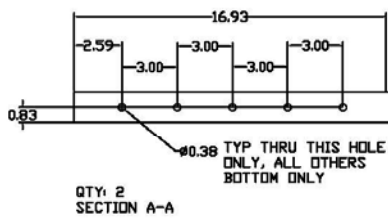
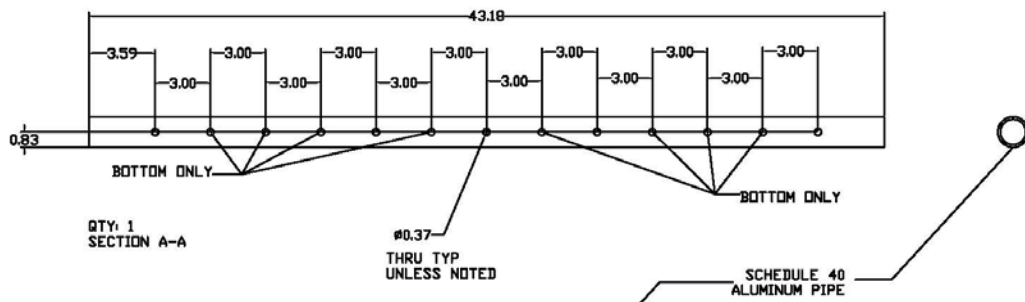
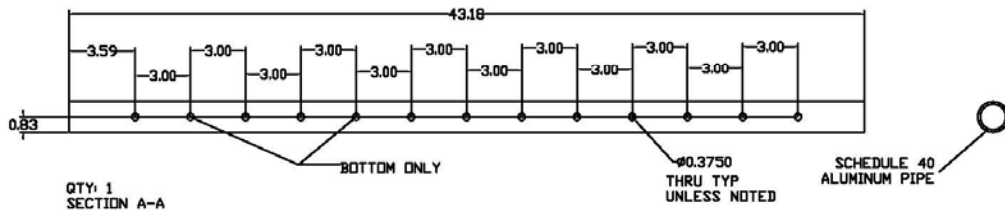

BOTCAM III FRAME
 PIPE SECTION A-A
 PART # 26, 27 AND 28

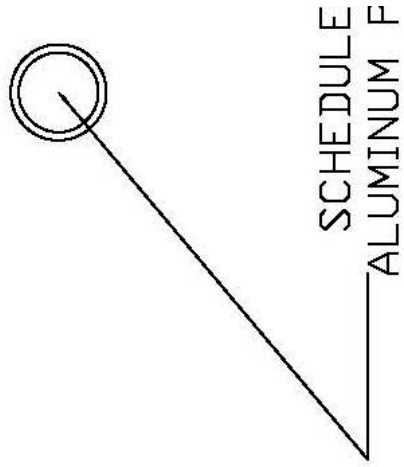
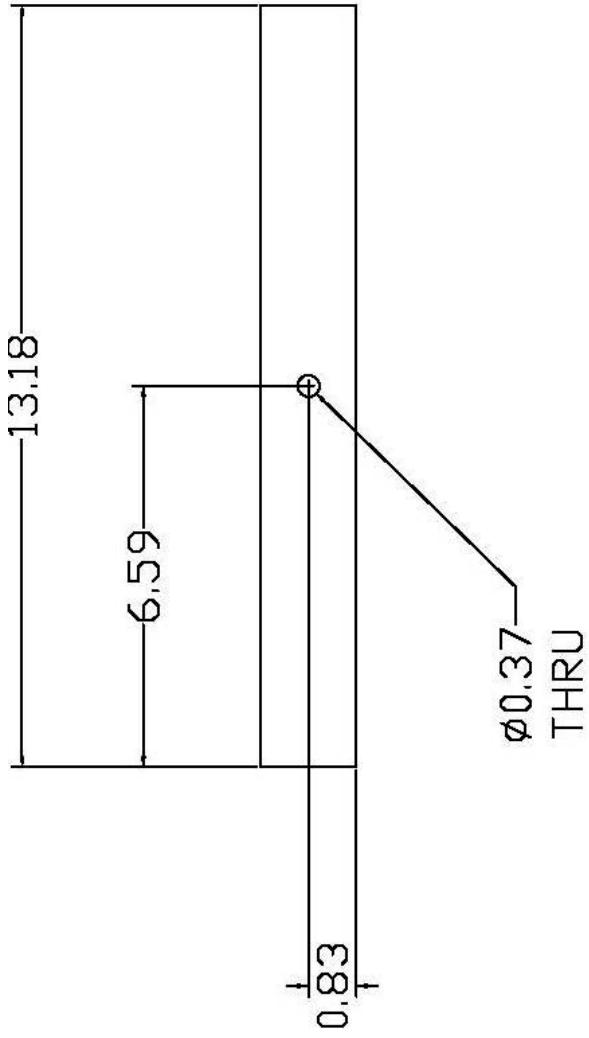

QTY: 4
FRONT

BOTCAM III FRAME
PIPE FRONT
PART # 29

8.7 Appendix 7: Prototype III Weight Estimates

Aluminum Pipe (Schedule 40)	Length	Width	Depth	Diameter	Density	Volume	Weight Air	Weight Water	Quantity	Total Weight Air	Total Weight Water
1/4" alum Plate	9.17	8.00	0.25		0.10	18.34	1.83	1.16	2.00	3.67	2.31
2"x2" Square	37.30	8.00	0.13		0.10	37.30	3.73	2.35	2.00	7.43	2.35
10 Guage Alum Channel	80.00	5.25	0.13		0.10	52.50	5.25	3.31	1.00	5.25	3.31
2"x1" L-bracket	81.36	3.00	0.25		0.10	61.02	6.10	3.84	1.00	6.10	3.84
2" flat bar	58.00	2.00	0.25		0.10	29.00	2.90	1.83	1.00	2.90	1.83
1/2" plate	6.00	6.00	0.50		0.10	18.00	1.80	1.13	2.00	3.60	2.27
2"x1" channel	47.30	4.00	0.13		0.10	23.65	2.37	1.49	1.00	2.37	1.49
1"x1" channel	99.40	3.00	0.13		0.10	37.28	3.73	2.35	1.00	3.73	2.35
Camera	9.55			3.48			5.70	2.31	2.00	11.40	4.62
Electronics	14.71			7.95		730.19	30.00	2.98	1.00	30.00	2.98
Seabird										0.00	0.00
SVS										0.00	0.00
Niskin										0.00	0.00
Acoustic Release							14.30	4.40	1.00	14.30	4.40
1 1/4" alum pipe	332.00			1.66	0.07	221.95	14.72	6.50	1.00	14.72	6.50
Hardware/Missing Components										10.00	5.00
Floatation	18.00	12.00	6.00		0.02	1296.00	21.00	-27.00	2.00	41.99	-53.99
									Total	153.75	-10.74

8.8 Appendix 8: Anchor Calculations and Design

Surface Line Drag Calculations					
Model Line as flow past a cylinder					
Assume:	free stream velocity $u \sim 0.5$ m/s throughout water column as conservative estimate				
	drag coefficient $C_d \sim 1.2$ (Fox and McDonald)				
	water density $\rho \sim 1025$ kg m ⁻³				
	rope length $L \sim 300$ m				
	rope diameter D				
	projected area $CSA \sim D * L$				
Equation:	$F_d = 0.5 * \rho * C_d * A * u^2$ where F_d is the drag force in N				
	Rope Diameter (in)	D (m)	CSA (m ²)	F _d (N)	
	0.25	0.00635	1.905	292.8938	
	0.375	0.009525	2.8575	439.3406	
	0.5	0.0127	3.81	585.7875	
Botcam Drag Calculations					
Assume:	Break up drag calcs into individual components:				
	velocity at botcam $u \sim 0.2$ m/s as conservative estimate				
drag coefficient:	cylinder	1.2			
(from F&M)	disk	1.17			
	square cyl	1.5			
Equation:	$F_d = 0.5 * \rho * C_d * A * u^2$ where F_d is the drag force in N				
Components Projected Areas:					
Frame	diameter = 1.66 in	A = 0.14 m ²	$C_d \sim 1.2$	F _d =	3.444
	length = 11 ft				
Foam	2x 6 in x 12 in	A = 0.093 m ²	$C_d \sim 1.5$	F _d =	2.85975
Electronics	diameter = 8 in				
	length = 18 in	A = 0.093 m ²	$C_d \sim 1.2$	F _d =	2.2878
Cameras	2x diameter = 3.5 in	A = 0.012 m ²	$C_d \sim 1.17$	F _d =	0.28782
				Total F _d (N)	F _{dt} = 8.87937
				*insignificant compared to rope drag	
If we assume all the drag force is in the horizontal direction (ie, it is not lifting the anchors off the bottom), then the drag force must be balanced by the friction force = $\mu * N$ or the coeff. static friction * normal force (weight)					
Therefore:	F _d ~ 450 N for 3/8" line				
	$\mu \sim 6$ for concrete on rock				
	therefore $N = \text{min. weight} = 750 \text{ N} = 170 \text{ lb}$				

8.9 Appendix 9: VMS Simplified Users Guide

Vision Measurement Software – VMS

Simplified Measurement Instructions

1. Create a folder. The folder should contain the two video files (.avi), the calibration file (.cal), the photo file (.pho) and the fish database (.spc).

To start a new project:

1. My Computer
 - a. C drive
 - i. Program Files
 1. VMS
 - a. VMS771
 - i. *Open vms.exe*
2. The VMS software should open:

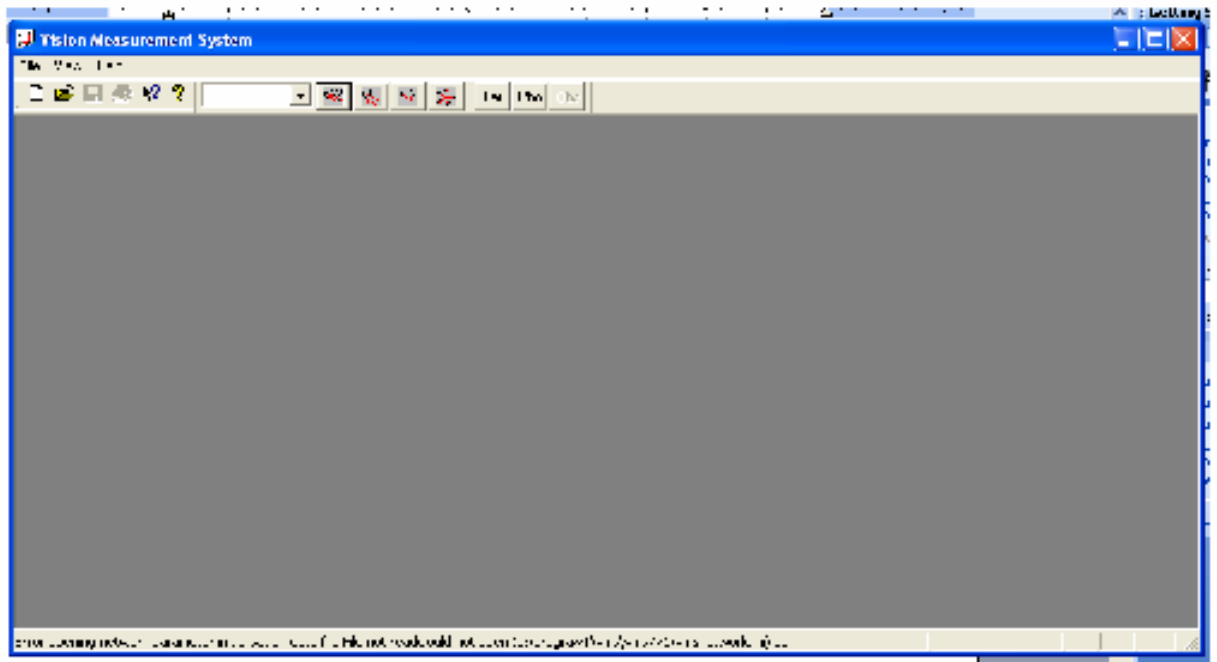

3. To start a new project:
 - a. File
 - i. Project
 1. New

4. A new window will pop up
 - a. Choose Sequence
 - b. Type in a name for the new project
 - c. Press enter or click OK

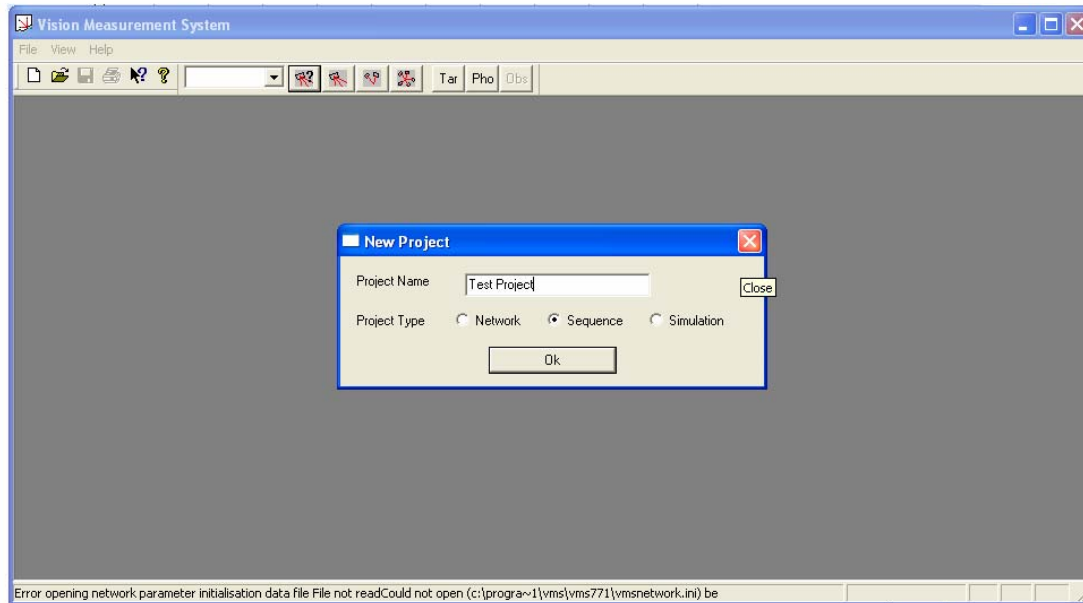

5. A new window will appear (“Sequence Project”)
 - a. *Choose* Movie Sequence
 - b. *Hit Enter or click OK*

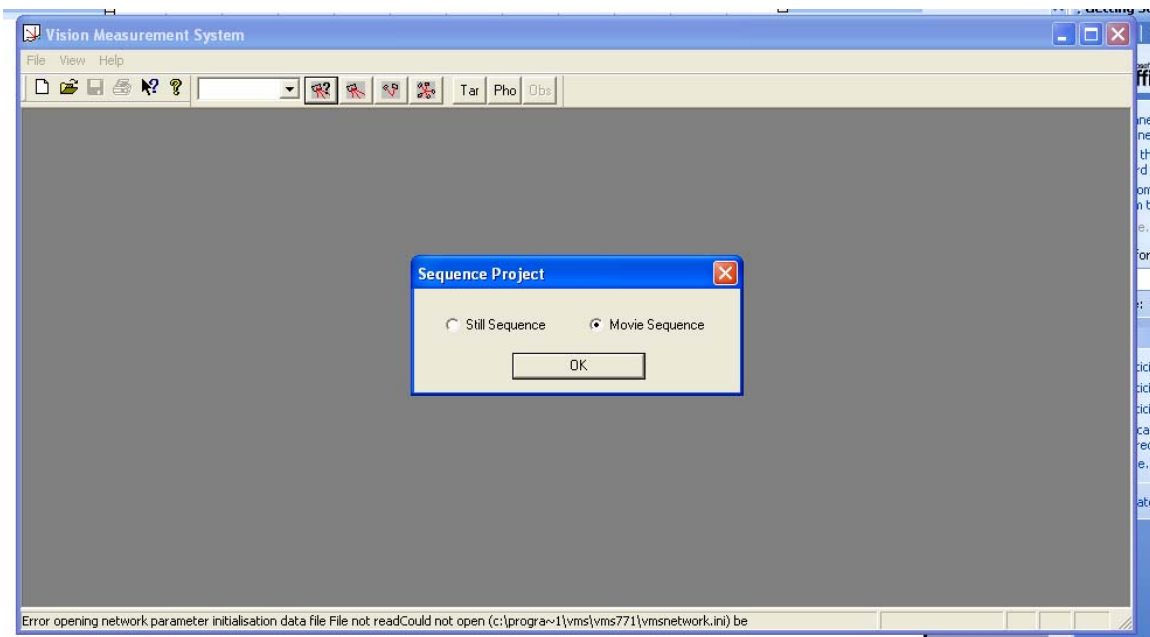

6. A new window will appear (“Create New Window Movie Sequence Project”). The project name should appear.
 - a. Directory: *click on the “...” button on the right.*
 - i. *Navigate to the file created previously with the .cal, .pho, .avi and .spc files.*
 - b. Target File: *click on the “...” button on the right.*
 - i. *Hit Enter to accept the default target file name.*
 - ii. *A window will pop up stated the target file doesn’t exist, do you want to create it. Click OK.*
 - c. Calibration File: *click on the “...” button on the right.*
 - i. *The calibration file (*.cal) should be visible in the window. Click on the *.cal file and press open.*
 - d. Photo File: *click on the “...” button on the right.*
 - i. *The photo file (*.pho) should be visible in the window. Click on the *.pho file and press open.*
 - e. Observations File: *click on the “...” button on the right.*
 - i. *Hit Enter to accept the default observations file name.*
 - ii. *A window will pop up stated the observations file doesn’t exist, do you want to create it. Click OK.*
 - f. Image Sequence Files:
 - i. Left: *click on the “...” button on the right.*
 1. *The left video file (*.avi) should be visible in the window. Click on the left *.avi file and press open.*
 - ii. Right: *click on the “...” button on the right.*
 1. *The right video file (*.avi) should be visible in the window. Click on the right *.avi file and press open.*
 - NOTE: none of the other parameters of this window should be changed
 - g. *Click on Verify files and continue button at the bottom of the window*

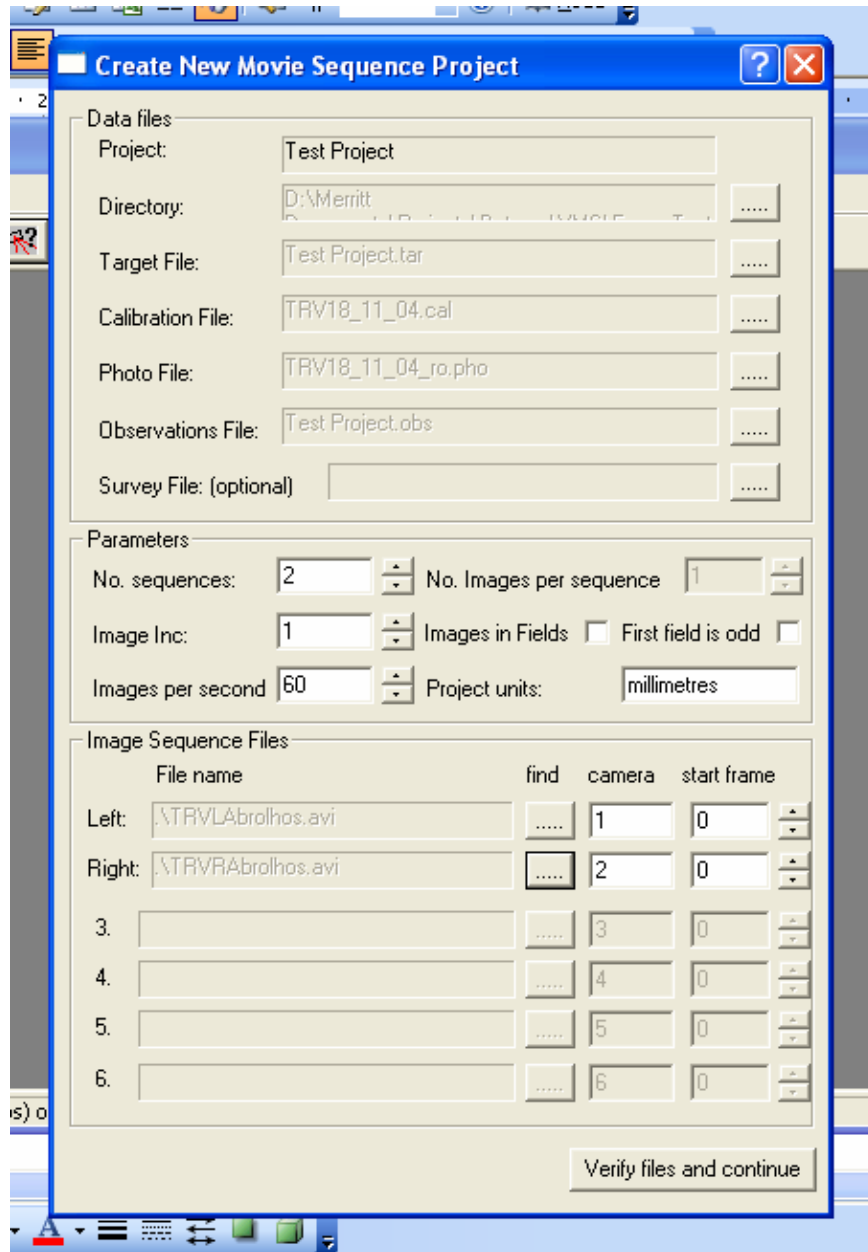

7. The VMS window should now look something like the frame grab below:
 - a. Maximize the VMS Window
 - b. Close the window on the left side within VMS titles "*.prj"

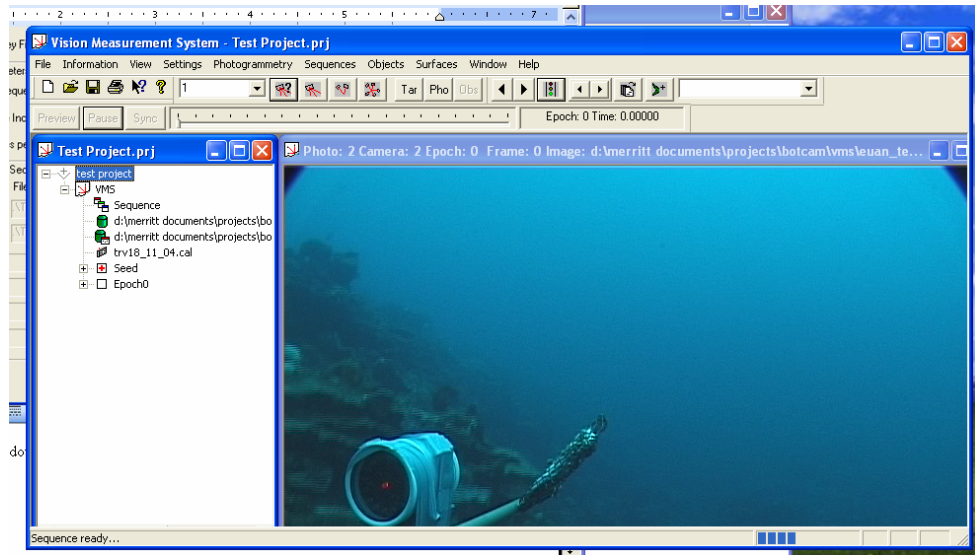

8. Look on the toolbar and find “Window”
 - a. Click on Window
 - i. Select tile vertical
 - ii. Note: You will want to see the extreme right side of the left image, and the extreme left side of the right image. In some versions of VMS and on some monitors, the bars controlling the vertical and horizontal locations of the image are not visible. Move the left and right frames around until you find the movement bars, make the necessary adjustments, and then move the frames back into place.
 - iii. The display should now look like the frame grab below.

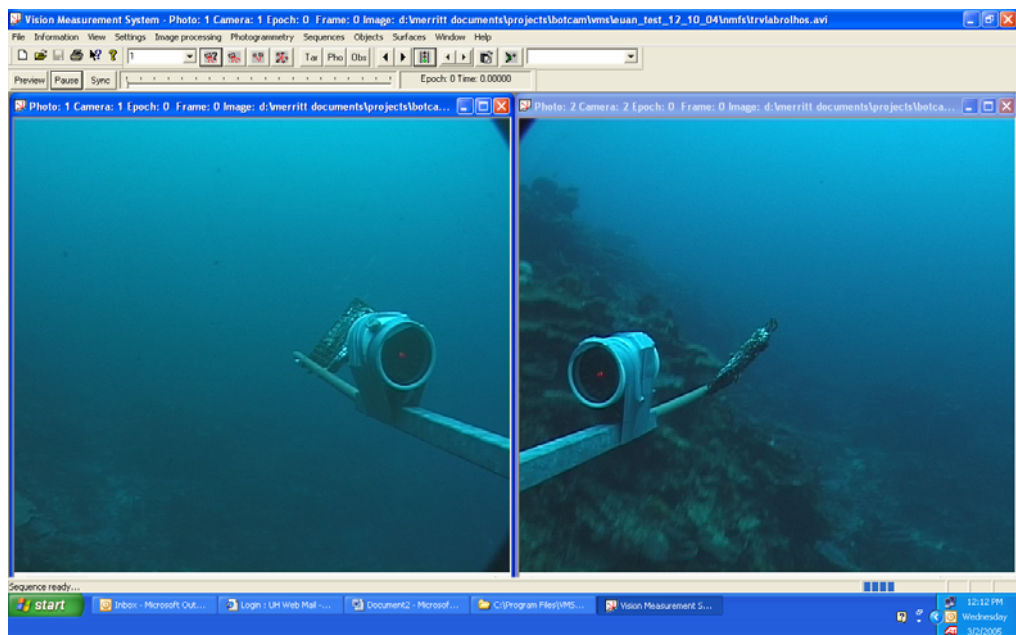

9. Look at the toolbar and find “Objects”
 - a. *Click on Objects*
 - i. *Select Load Object Database*
 1. The project directory should open and you should see the *.spc file. *Open the *.spc file.* You should now see a combo box on the far right of the toolbar with a list of your species.

10. Look at the toolbar and find “Settings”
 - a. *Click on Settings*
 - i. *Select Image Measurement Parameters*
 - ii. A new window will pop up.
 1. *Change the Image Measurement Method from Centroid to Manual (at the top).*
 2. *On the next lines down, change the Target image window size (pixels): X and Y from 20 to 60.*
 3. *No other changes are necessary, click Update.*
 - b. *Click on Settings*
 - i. *Select Photogrammetric automation*
 1. *Select Epipolar*
 - a. *Select Draw epipolar lines*
 - ii. NOTE: this option will help you identify the same fish between the left and right images by drawing a horizontal line through the point selected in the other image.

11. The left and right images now need to be synchronized. Look on the toolbar. Toward the right side you should see two sets of arrows, a large pair to the left and small pair to the right separated by a traffic light button. The large pair moves both frames together. The small pair moves only the active image frame.
 - a. In order to synchronize the images, the frames must be adjusted so that the lights on the diode device match in both the left and right images.
 - b. The two image frames should begin fairly closely synchronized (within a few frames). Using the **large arrows**, move forward (right large arrow) until you see a light appear on the diode in one of the images.
 - c. Next, using the **small arrows**, move the image in which the diode light does NOT appear forward until the same diode light is visible.
 - d. Once the same diode light is visible in the both the left and right images, press the traffic light button on the toolbar to synchronize the two images. At this point, the small arrows should not be used unless there is drift between the left and right images.

12. To make a measurement, move both frames forward using the **large arrows** until you find something you would like to measure that is visible in both the left and right images.
 - a. The default incremental step forward is 1 frame. You can change this to whatever value you would like by pressing the button directly to the left of the small arrows on the toolbar. Press the button, enter the frame increment desired, and press OK.

13. Once you find a target you would like to measure, click near one end of the object (the nose of a fish for example) in the left (or right) image. A new window should appear that shows a blown up image around the area you clicked on. See the frame grab below.
 - a. Click on the exact location desired (nose of fish).
 - b. The epipolar line should now appear in the other image helping you identify the same object in the other image.
 - c. Repeat this process for the right (or left) image clicking near the same location of the same object (nose of fish).
 - d. After selecting exactly the same position in both the left and right images, you need to press the “tail” button on the toolbar. This button is located on the right side of the toolbar immediately to the left of the combo box with the fish species list, and to the right of the small arrows and the increment button. It looks a bit like a fish tail with a + to the right. Press this button.
 - e. You now need to repeat the process for the other end of the object in both images (for the fish tail). Click near the other end (tail) in the left (or right) image. You will get the same blow up box as before. Click on the exact location.
 - f. Repeat step (e) for the right (or left) image.
 - g. Now choose the name of the object (fish species) from the combo box at the far right of the toolbar. If you click on the arrow, you should get your entire list of names. Choose the correct one.
 - h. The object name, length and precision should now appear in both the left and right images.
 - i. You can now make another measurement at this same frame number or move forward to make another measurement.

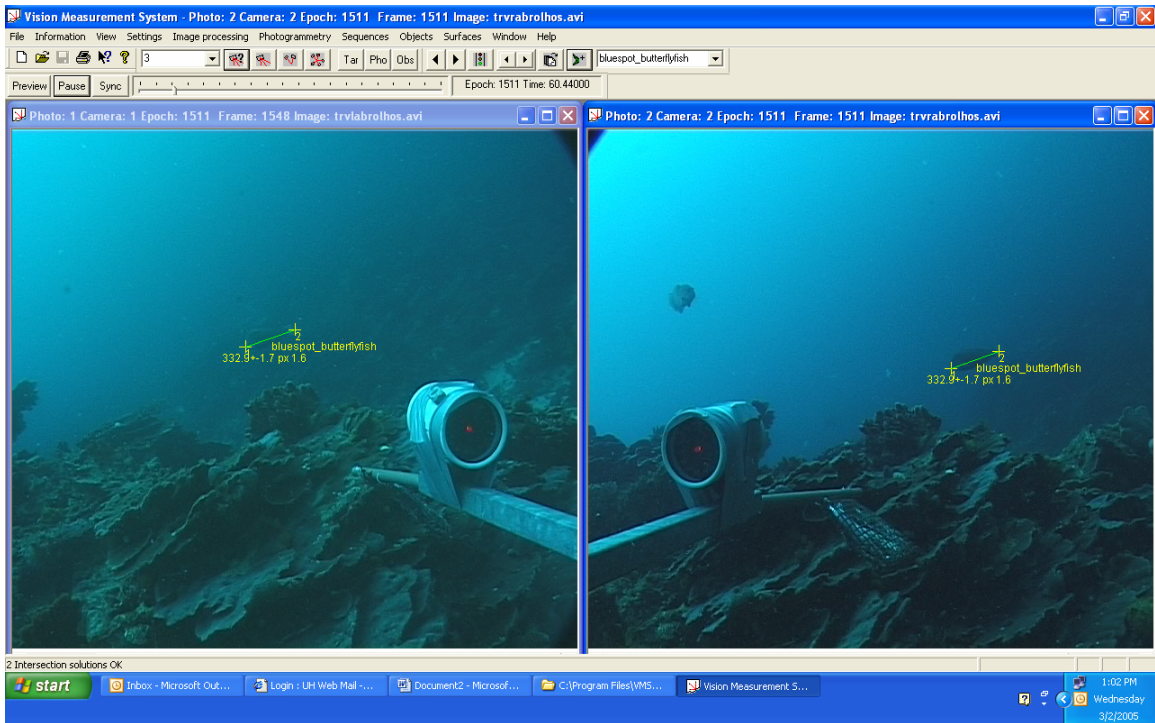
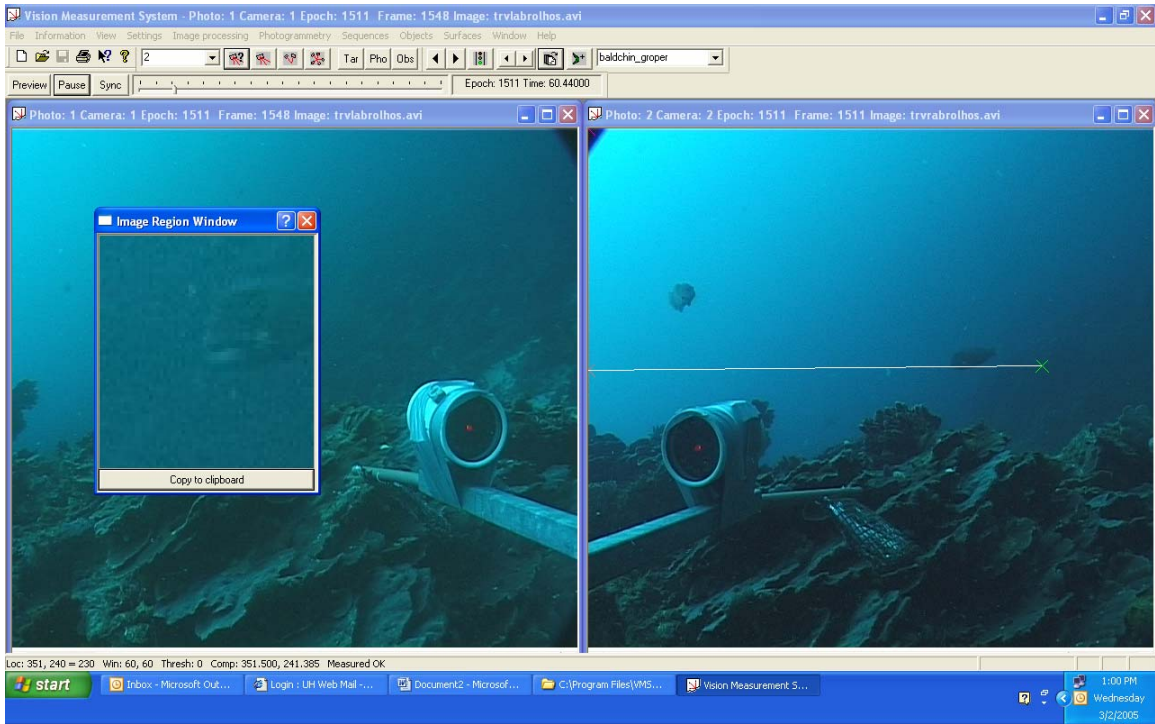

14. To see more information about a measurement, prior to a measurement:
 - a. Click on Objects in the toolbar
 - i. Select Object Information

- ii. A new window with appear with more information about the measurement
- 15. To save the measurement(s) into a .dat file which can be imported in programs like Excel:
 - a. Click on Objects in the toolbar
 - i. Select save object data file

8.10 Appendix 10: Botcam Operations

Botcam Operations

Equipment:

1. Botcam
2. Laptop or PC with VMS, Viperfish Viewer and Seabird SeaTerm software installed
3. Cross-over cable
4. Seabird 39 communications cable and usb to serial port adapter (if necessary)
5. IXSEA TT701 Acoustic Telecommand Unit
6. DR-500 Direction Finder
7. Surface Line (500 m)
8. Surface Signature (High Flyer and Mooring Ball)
9. Anchors
10. Bait
11. Burn Wires
12. Viperfish Deep Charger
13. BWR Battery Charger
14. DR-500 Battery Charger
15. IXSEA TT701 Battery Charger
16. Spare Parts (see spare parts list)
17. Crane, Boom or A-frame with Mechanical Lifting Power
18. Pinch Puller or Pot Hauler

Preparations:

1. Bait

Bait is a 50/50 mix of squid and opelu. The squid-opelu mixture should be ground together until the largest pieces are about 1 inch on the largest axis. Mixing is made easier if the bait is semi-frozen while being ground. The ground mixture should be stored in seal-a-meal type bags. Each bag should contain 1 liter of the mix. The bags should be frozen until a couple of hours before their scheduled use. It is important that a standard bait mix be used. Contact Chris Kelley of the Hawaii Undersea Research Laboratory regarding this mix (ckelley@soest.hawaii.edu).



Figure 1. Bait Processor

2. Anchors

Total anchor weight should be 100 pounds (submerged weight) per drop at a minimum. While any material can be used, the more inert the better. The weights should also be considered sacrificial. Concrete is widely chosen as it is relatively inexpensive and non-reactive. Its low density, however, means that 100 submerged pounds is about 200 pounds in air (~ 1 cu. Foot). Also, any shape can be used, however, a shape that will tend to grab holes and ledges on the bottom will assist with dragging issues. A simple solution is to fill standard two standard 16 x 8 x 8 cinder-blocks stacked on top of each other with concrete. A chain set in the concrete prior to hardening makes for a good tie in location. Two

of these combined sets will be good for one drop. Each individual weight is limited in size (~100 pounds in air) to allow one or two people to move them.



Figure 2. Example of Anchoring Technique

The anchor line should be made of a non-floating material. The breaking strength should be greater than 1000 pounds. Note that this load makes the acoustic release the weak link. Any non-floating material can be used, however, a biodegradable line is considered preferable. Anchor lines should be cut in 20 foot sections. These sections should be folded in half and the closed end tied with an overhand knot as shown in the figure below, leaving an approximate 12-inch loop as a connection point for the acoustic release. The two bitter ends are then tied to the anchor(s).

3. Batteries

NOTE: All battery changes and charging should be done in as clean and dry a location as possible. The battery use spreadsheet should be updated daily.

- a. RF-700C1 Radio Beacon and Strobe: This unit uses 4 standard D-cell batteries. These batteries should be changed after every 8 days of use.
- b. RF-700C6 Radio Beacon and Strobe: This unit uses 6 standard D-cell batteries. The batteries should be changed after 8 days of use.
- c. DR-500 Direction Finder: This unit uses a lithium ion rechargeable battery. The unit can run for 10 hours on one battery or continuously on an AC or DC power supply. The battery should be charged after each use to maintain full battery power.
- d. SVS: This unit uses 3 standard D-cell batteries. The batteries should be changed after 48 hours of continuous operation.

- e. BWR: This unit uses a custom Ni-MH rechargeable battery pack. A minimum of two battery packs should be supplied with each unit along with a custom charger. The batteries should be changed after every 3 deployments. The second battery should always be charging or fully charged.
- f. Viperfish Deep: The Viperfish Deep Unit has internal rechargeable batteries that allow for at least 3 hours of recording operations. Fully depleted batteries should be charged for a minimum of 12 hours using the provided AC charging unit. In order to save battery life, it is recommended that video download be performed using the AC charging unit power as well.
- g. Ixsea AR701 Acoustic Release: This unit uses 18 standard C-cell batteries. The batteries should be changed every XX releases. Refer to the AR701 user manual for specific instructions on changing these batteries.
- h. IXSEA TT701 Telecommand Unit: This unit uses a built-in rechargeable lead-acid battery. The battery allows for 60 hours of operation. The battery should be charged with the supplied AC power supply on a daily basis in order to maintain the charge. A red LED will light up to warn of a low battery.
- i. Seabird 39 Temperature and Pressure Recorder: This unit uses a standard alkaline 9V battery. This battery should be changed every 5 days based on a 1 second constant sampling interval.

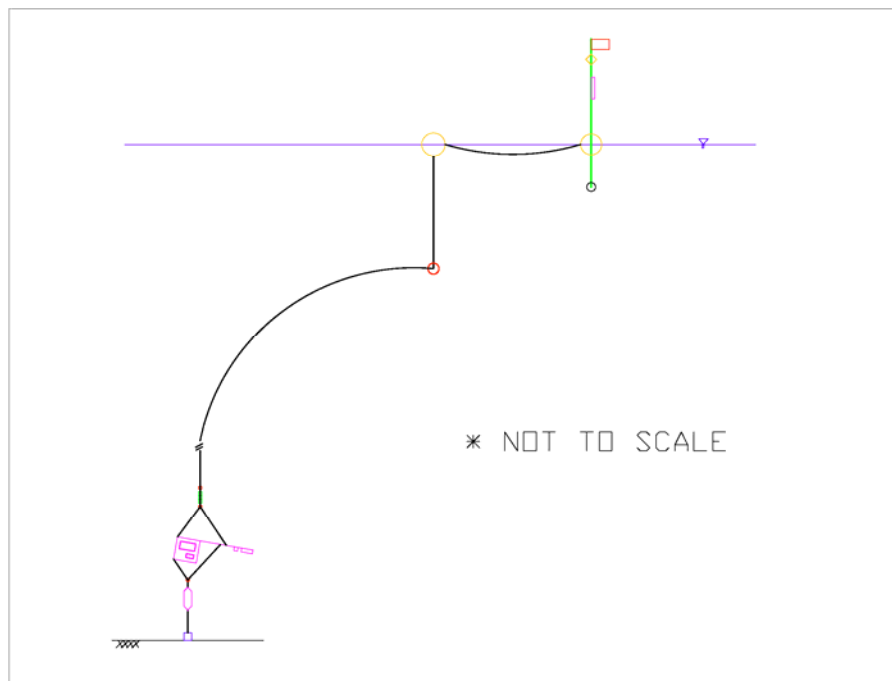

Figure 3. Schematic of Deployed System

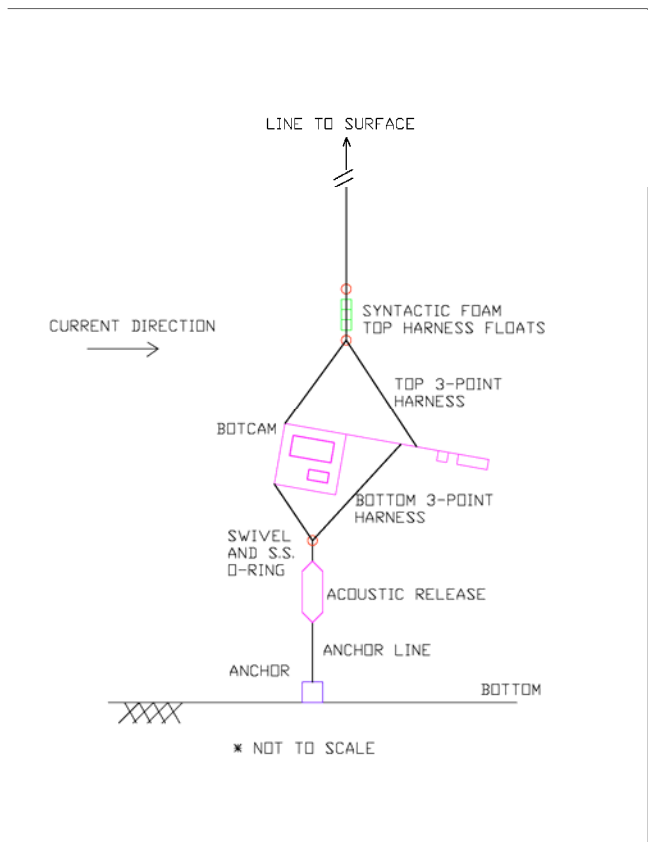

Figure 4. Schematic of Botcam deployed on bottom

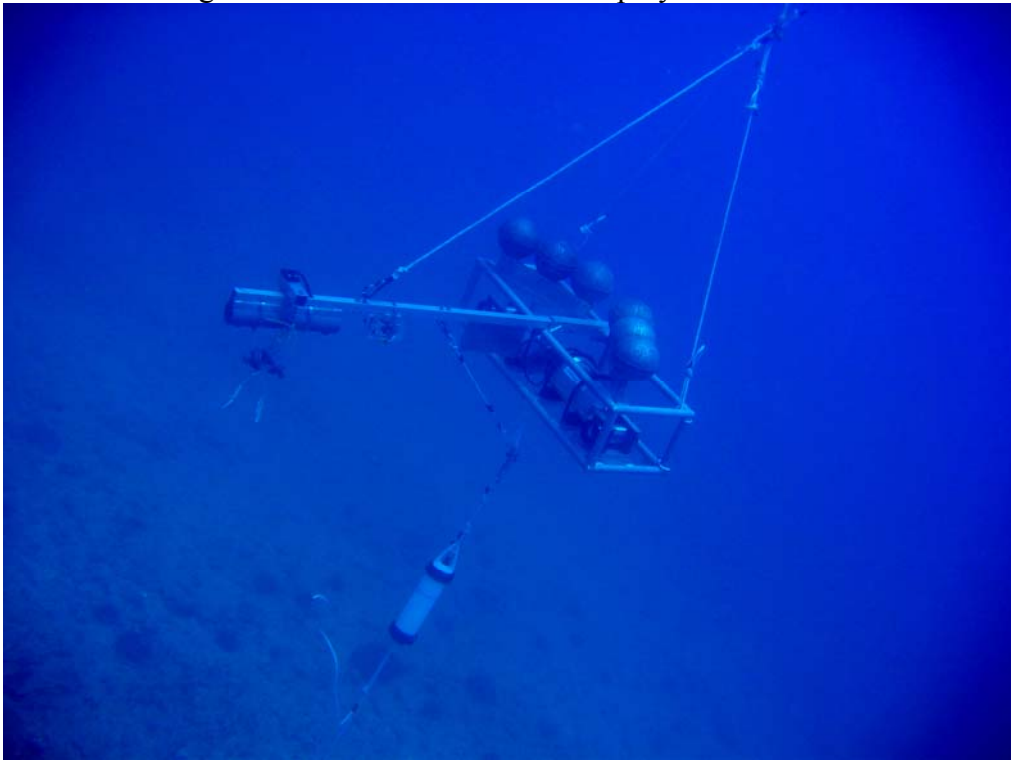

Figure 5. Picture of Botcam Deployed

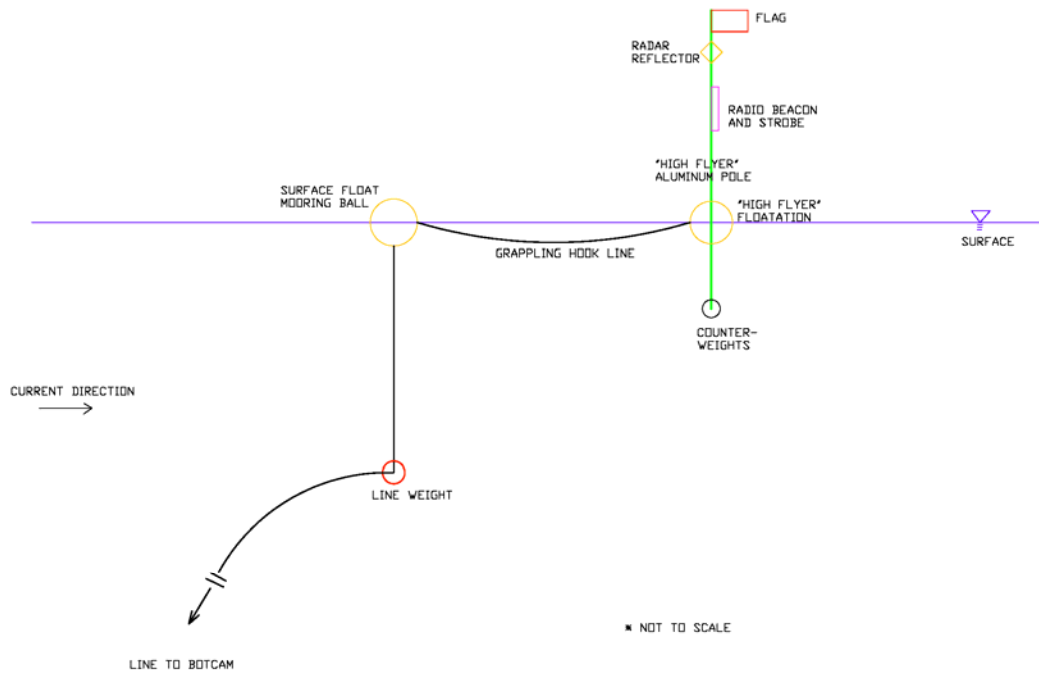

Figure 6. Schematic of Surface Signature



Figure 7. Picture of Surface Signature

Shipboard Deployment:

1. Check the battery field log. Change batteries on individual components as necessary.
2. Bring together the Botcam and bait arm, the anchor(s), the surface line and the surface signature at a location on the ship deck in which the crane can pick the entire assembled Botcam, the top and bottom harnesses, the acoustic release and the anchors.
3. Prepare the surface line
 - a. Based on a shipboard sounding at the drop location of interest, assemble enough length of surface line plus 2 additional sections. The line is divided into 20 fathom sections. All shackles must be locked with zip-ties or bailing wire.
4. Attach a new LK-80 burn wire
 - a. Inspect the burn wire to confirm the paint is intact on the wire
 - b. Take care that the o-ring goes into the PVC tip after the burn wire
5. Fill the bait container
 - a. Close one end of the bait container using a truckers knot on the burn wire side.
 - b. Cut open one bait bag and empty the contents into the Niskin bottle.
 - c. Top off the Niskin Bottle with salt water.
 - d. Cap the other end of the bottle again using a truckers knot on the burn wire side.
6. Attach the bait arm
7. Connect the burn wire plug to the burn wire relay
8. Connect the auxiliary can to the deep unit
9. Check that both cameras are connected to the deep unit
10. Check that a dummy plug is installed on the data bulkhead connector
11. Program the Seabird 39 to start recording
 - a. See SBE 39 user manual for operating procedures.
12. Check the settings on the SVS and turn it on.
 - a. See SVS user manual for operating procedures.
13. Attach the top harness
14. Attach the bottom harness with acoustic release connected
15. Attach the anchor(s)
 - a. Attach anchor(s) to the bitter end(s) of the anchor line
 - b. Using the TT701 acoustic release telecommand unit, release the AR701 acoustic release pin. (see TT701 operating manual for complete instructions)
 - c. Insert the anchor line loop into the acoustic release pin and arm the acoustic release using the TT701. (see TT701 operating manual for complete instructions)
16. Program the start and stop recording time.
 - a. Using the custom auxiliary can tool, open the auxiliary can and program the recording start and stop time.

- b. For complete instructions on timer use, see programmable timer installation instructions.
 - c. While the can is open, visually inspect the o-ring for damage or debris and change if necessary.
 - d. Close the auxiliary can making sure the cap and o-ring make a good seal.
17. Begin filling out the field data sheet
- a. Be especially careful to record the serial number (S/N) of the acoustic release.
 - b. Also be careful to record the radio frequencies of the RF-700C1 and RF-700C6 units.
18. Attach surface line to top harness
19. Attach top harness to crane line with quick release sea-catch
20. Turn on and attach Seimac RF700-C6 to top of harness
21. Be sure the ship is in place for the drop
22. Lift entire unit with crane over the side of the ship and lower into water.
- a. Easily released tag lines should be used to control the botcam as it is lifted and transferred to the water.
23. Cleat off the surface line
24. Release the sea-catch to transfer control of the Botcam to the surface line.
25. Record a gps location and time on the data sheet
26. Lower the unit to the bottom by hand.
- a. One person can control the fall of the Botcam using a wrap or two on a cleat, however, a second person should be standing by helping to feed out the line.
 - b. If the bottom is not reached at the depth expected, be prepared to add more sections of line.
 - c. If the bottom is not reached within 10 sections of line, the location is either too deep (> 200 fa or 350 m) or the ship is trawling with the unit. Neither of these scenarios is good and the unit should be recovered.
 - d. Once the bottom is reached, record a gps location, time and sounding depth on the field data sheet.
 - e. Once the bottom is reached, 2 additional sections of line should be added before the surface signature (mooring ball and high flyer) is attached and deployed.
 - i. Note, for larger sea states, an additional section of line can be added.
 - ii. Note that at no time should more than 14 sections of line be used on a deployment.
 - f. A 2 to 5 lb. line weight should be added between the last 2 sections of surface line (i.e. the weight should sit at ~ 20 fa). The amount of weight should vary with sea state.
27. Turn on the RF700-C1 attached to the high flyer.
28. Making sure the surface line is attached to the surface mooring ball, and the surface mooring ball is attached to the high flyer, deploy the entire surface signature.

29. Time permitting, stay in the general vicinity and observe the surface signature to see if the unit appears to be dragging on the bottom.

Recovery:

1. Return to the GPS location.
 - a. The surface signature should be clearly visible to the naked eye from hundreds of meters away. If it is not visible, first check the ship's radar to see if the unit is found. If not, go to a high point on the ship and attempt to get a signal with the DF-500 Directional Finder.
 - b. If none of the above methods work send a release signal with the TT701 from the GPS bottom location on the field data sheet. This is in case the line parted but the botcam is still anchored on the bottom. (See TT701 user manual for specific instructions on its use). The unit should take between 5 and 10 minutes to reach the surface from a 300 meter depth. The DF-500 directional finder can be used to track the RF-700C6.
 - c. This process should be repeated a minimum of two times. If the unit is not found and time permits, a search pattern for the surface signature should begin.
 - d. Note that the most likely scenario for not finding the surface signature at the GPS location is that the botcam was dragged into water deeper than the surface line and the whole system is floating down current.
2. Once at the surface signature, the ship should be positioned up-current of the high flyer but close.
3. Send an acoustic release signal with the TT701 telecommand unit.
 - a. Be sure that the correct serial number is entered into the TT701
 - b. Be sure the transducer is hung below the hull of ship.
4. The botcam should float to the surface within 5 to 10 minutes from 300 meters depth.
 - a. If the botcam does not pop up, the signal should be sent at least 2 more times with a 5 to 10 minute wait between signals.
5. Once the botcam reaches the surface, the ship should approach the surface signature taking care to stay clear of the surface line.
 - a. The line between the surface mooring ball and the high flyer should provide a good target for a grappling hook.
 - b. Once the line is secured the high flyer and mooring ball should be hauled on board.
 - c. The surface line can then be pulled in by hand or via a pot-hauler or pinch-puller. The surface line should be fed into an empty container to avoid future kinks.
6. Once the botcam is alongside the ship, it can be picked out of the water via the crane or hauled out by hand. The unit will weigh approximately 150 lbs in air without the anchors.
 - a. Tag lines can be attached using specialty tools such as a "Happy-Hooker"

- b. Special care must be taken to avoid hitting the bait arm on the side of the ship.
- 7. If for some reason the botcam does not float to the surface, the surface signature should be brought on board and the surface line passed through the ships pot-hauler/pinch-puller.
 - a. Special care should be taken to keep the ship directly over the top of the unit to avoid dragging the botcam along the bottom risking either the anchors or the botcam itself being jammed into a hole and becoming stuck, potentially damaging the botcam due to impacts, and/or damaging the benthic substrate.
 - b. If this method of recovery is used because the acoustic release did not function correctly, it will not hurt to continue to send the release signal as the unit comes up.
- 8. Turn off the SVS
- 9. If the unit is not going to be quickly redeployed, stop the sea-bird recording.
- 10. If the unit is not going to be quickly redeployed, turn off the RF700C1 and RF700C6 radio beacon/strobes.
- 11. Note any problems associated with the recovery or obvious damage to the unit on the field data sheet.

Video Download and Storage:

Instructions for slow turn-around time (> 1 hour)

- 1. Immediately rinse the entire unit with fresh water.
- 2. If possible, move the botcam to a dry, shaded location.
 - a. Note that the Deep unit should not be booted in the air in direct sunlight. The Deep housing acts as a heat sink to cool the internal components when in the water, but the unit can quickly overheat if run in direct sunlight.
- 3. Attach AC power
 - a. Unplug the auxiliary can
 - i. Be sure to insert a dummy plug into the end of this cable
 - b. Plug in the AC power
- 4. Plug in the communications cable
 - a. The communications cable should connect to a wet pluggable connector on the Deep unit.
 - b. This wet pluggable connector should lead to a usb to Ethernet converter which can be used with a cross-over cable to communicate with a PC.
 - c. Attach the cross-over cable to the PC's Ethernet port.
- 5. Boot the Deep System
 - a. Give the unit about 5 minutes to boot. Green lights should be visible on the usb to Ethernet converter.
 - b. If you do not give the system enough time to boot, communications between the pc and the deep unit will not be properly established.

6. Establish a connection
 - a. Right click on the Windows “Start” button
 - b. Choose Explore
 - c. In the address line type: [\\192.168.1.1](http://192.168.1.1) and press Enter
 - i. Note that during the boot up process, the pc assigns this IP address to the Deep unit.
 - d. A folder should open
 - i. Open the GSX file
 - ii. Open the Video file
 - e. Once the Video file is open, all of the .avi files will be visible sorted by a file name including start date and start time. These files can now be transferred to a local drive on the pc.
 - i. Copying 2 hours of video (1 hour from each camera) should take approximately 20 minutes.
 - ii. There is no need to delete files on the Deep unit as they will be over-written. The Deeps hard drive can store data from 15 to 20 one hour deployments. Oldest records will be over-written first.
 - f. For detailed instructions, see the Viperfish Deep User Manual.
7. After the files are transferred, the Deep unit can be shut-down and the communications cable removed.
 - a. Be sure to replace the dummy plug onto the communications bulkhead connector.
 - b. If the unit is not going to be immediately re-deployed, leave the AC power attached in order to charge the batteries.
 - i. Be sure to note the charging time and date on the battery field sheet.
8. Connect to the Seabird 39
 - a. If the unit is still recording data, stop it.
 - b. Download the data to an appropriate folder.
 - c. Do not delete the data on the Seabird 39 until the data has been viewed to make sure the transfer was completed.
 - d. Disconnect from the Seabird
 - e. For detailed instructions on Seabird communications, see the Seabird 39 User Manual.
9. Move to an air conditioned space with the PC/Laptop and immediately transfer the files to the appropriate external hard drive.
10. Time permitting, quickly view the video to make sure there are no obvious problems with the system.
11. As soon as it is convenient, archive the video to DVD.
 - a. Both video streams from a single deployment should fit on one DVD. Video file size is limited to 2.3 GB per file to allow them to fit on a DVD. If multiple files are necessary for any given deployment, the corresponding left and right should be kept together.

Immediate Re-Deployment

1. If the unit is to be immediately re-deployed, then data download procedures can be skipped.
 - a. Note that time permitting, video data should be collected at a minimum whenever possible in case the botcam is lost.
2. The botcam is supplied with multiple bait arms and bait release equipment which can be prepared in advance of the botcam recovery.
 - a. Repeat steps 4 and 5 from the shipboard deployment section.
3. Once the botcam is on board, swap out bait arms
 - a. Unplug the burn wire from the BWR
 - b. Detach the top and bottom harnesses and remove necessary pins.
 - c. Insert the new bait arm
 - d. Reattach the top and bottom harnesses
4. Check the battery field log to make sure no batteries need to be changed or replaced.
 - a. Note that in most scenarios, the Deep batteries will be the limiting factor controlling the number of deployments that can be done in a row.
5. Repeat the steps for Shipboard Deployments as necessary.

Daily Maintenance:

1. The most important daily maintenance is a good fresh water bath after deployments are completed.
2. It is critical that all of the connectors be cared for.
 - a. Keep the connectors either plugged in or covered with a dummy plug at all times other than when plugging in or out or for inspections.
 - b. Visually inspect the connectors on a daily basis looking for corrosion and damage to the sealing features.
 - c. Add silicone to sealing features every 3rd day.
 - d. If corrosion is found on the connectors, clean with an electrical contact cleaning agent.
3. Check the o-ring on the auxiliary can and lubricate daily.
4. Visually inspect the entire system for obvious damage from impacts, corrosion, sun damage, and general wear and tear.
 - a. Give special care to visually inspecting the surface line, harnesses and associated hardware. Replace as necessary.
5. Check that all components are securely fastened to the frame and tighten as necessary.
6. Store the botcam in the coolest, driest location possible and be sure to keep it out of direct sunlight.

8.11 Appendix 11: Hawaiian Target Fish List

NWHI Fish list					
Category	Group	Org Name	Day/night	Day	Night
Fish	acanthurid	Naso hexacanthus	x		
Fish	acanthurid	Naso maculatus			x
Fish	acropomatid	Synagrops argyrea	x		
Fish	ammodytid	Ammodytoides sp	x		
Fish	apogonid	Lachneratus phasmaticus			x
Fish	argentinid	Glossanodon struhsakeri	x		
Fish	ariomatid	Ariomma luridum	x		
Fish	bembrid	Bembradeum roseum	x		
Fish	bembrid	Bembrops sp 1	x		
Fish	berycid	Beryx splendens			x
Fish	bothid	Bothus thompsoni			x
Fish	bothid	Chascanopsetta prorigera	x		
Fish	bothid	Parabothus coarctatus	x		
Fish	bothid	Taeniopsetta radula	x		
Fish	callanthiid	Grammatonotus laysanus	x		
Fish	callanthiid	Grammatonotus sp 1	x		
Fish	callionymid	callionymid		x	
Fish	caproid	Antigonia eos	x		
Fish	carangid	Decapterus tabl			x
Fish	carangid	Pseudocaranx dentex	x		
Fish	carangid	Seriola dumerili	x		
Fish	carangid	Seriola rivoliana	x		
Fish	carapid	Pyramodon ventralis			x
Fish	carapid	Snyderidia canina			x
Fish	carcharinid	Carcharhinus galapagensis			x
Fish	carcharinid	Carcharhinus plumbeus	x		
Fish	chaetodontid	Chaetodon femblii	x		
Fish	chaetodontid	Forcipiger sp		x	
Fish	chaetodontid	Heniochus diphreutes	x		
Fish	chaetodontid	Prognathodes guezeti	x		
Fish	chaetodontid	Roa excelsa	x		
Fish	chaunacid	Chaunax umbrinus	x		
Fish	chlorophthalmid	Chlorophthalmus prordens	x		
Fish	congrid	Ariosoma marginatum	x		
Fish	congrid	Bathyrcongery vicinus			x
Fish	congrid	Conger oligoporus			x
Fish	congrid	Gnathopis nystromi			x
Fish	congrid	Gnathopis sp			x
Fish	congrid	Uroconger lepturus			x
Fish	draconettid	draconettid		x	
Fish	emmelichthyid	Emmelichthys karnellai	x		
Fish	emmelichthyid	Emmelichthys struhsakeri	x		
Fish	emmelichthyid	Erythrocles scintillans	x		
Fish	epigonid	Epigonus atherinoides			x
Fish	epigonid	Epigonus devaneyi			x
Fish	epigonid	Epigonus glossodontus		x	
Fish	fistulariid	Fistularia petimba			x
Fish	gempylid	Rexea nakamurai	x		
Fish	holocentrid	Myripristis chryseres	x		
Fish	holocentrid	Ostichthys sp		x	
Fish	holocentrid	Pristilepis oligolepis	x		
Fish	hoplichthyid	Hoplichthys citrinus			x
Fish	labrid	Bodianus bilunulatus	x		
Fish	labrid	Bodianus cylindriatus	x		
Fish	labrid	Bodianus sanguineus	x		
Fish	labrid	Bodianus vulpinus	x		
Fish	labrid	Cimilabrus jordani		x	
Fish	labrid	Coris ballieui	x		
Fish	labrid	Labroides pthiropagous	x		
Fish	labrid	Suezichthys notatus	x		
Fish	labrid	Xyrichtys pavo		x	
Fish	lophiid	Lophiodes sp		x	
Fish	lutjanid	Aprion virescens	x		
Fish	lutjanid	Etelis carbunculus	x		
Fish	lutjanid	Etelis coruscans	x		
Fish	lutjanid	Lutjanus kasmira			x
Fish	lutjanid	Pristipomoides auricilla		x	
Fish	lutjanid	Pristipomoides filamentosus	x		
Fish	lutjanid	Pristipomoides sieboldii	x		
Fish	lutjanid	Pristipomoides zonatus	x		
Fish	lutjanid	Randallichthys filamentosus	x		
Fish	macroramphosid	macroramphosid			x
Fish	macrourid	Hymenocephalus antraeus			x
Fish	macrourid	Hymenocephalus sp	x		
Fish	macrourid	macrourid sp3			x
Fish	macrourid	Ventrifossa ctenomelas			x
Fish	monacanthid	monacanthid		x	
Fish	monacanthid	Thamnaconus garretti		x	

Category	Group	Org Name	Day/night	Day	Night
Fish	morid	Gadella molokaiensis			x
Fish	morid	Gadella sp			x
Fish	morid	Laemonema rhodochir	x		
Fish	morid	Physiculus grinelli			x
Fish	morid	Physiculus nigripinnis	x		
Fish	morid	Physiculus rhodopinnis			x
Fish	morid	Physiculus sterops			x
Fish	mullid	Parupeneus chrysonemus	x		
Fish	muraenid	Gymnothorax berndti	x		
Fish	muraenid	Gymnothorax nuttingi	x		
Fish	muraenid	Gymnothorax steindachneri	x		
Fish	myctophid	Benthoosema fibulatum			x
Fish	myctophid	myctophid			x
Fish	myliobatid	Manta sp		x	
Fish	nettastomatid	nettastomatid			x
Fish	nettastomatid	Saurenhelys stylurus			x
Fish	ogcocephalid	Halieutaea retifera			x
Fish	ogcocephalid	Malthopsis sp	x		
Fish	ophichthid	Myrichthys magnificus	x		
Fish	ophichthid	ophichthid			x
Fish	ophidiid	Brotula multibarata		x	
Fish	ophidiid	Ophidion muraenolepis			x
Fish	ophidiid	Xyelacyba myersi			x
Fish	oplegnathid	Oplegnathus punctatus	x		
Fish	ostraciid	Kentacapros aculeatus		x	
Fish	ostraciid	Lactoria sp		x	
Fish	pentacerotid	Evistias acutirostris			x
Fish	pentacerotid	Pseudopentaceros richardsonii		x	
Fish	percophid	Bembrops filifera			x
Fish	percophid	Chironema chryseres	x		
Fish	percophid	Chironema squamiceps	x		
Fish	pinguipedid	Parapercis roseoviridis	x		
Fish	pinguipedid	Parapercis schauanlandi	x		
Fish	plesiobatid	Plesiobatis daviesi	x		
Fish	polymixiid	Polymixia berndti			x
Fish	pomacanthid	Desmoholacanthus arcuatus	x		
Fish	pomacanthid	Genicanthus personatus	x		
Fish	pomacentrid	Chromis struhsakeri	x		
Fish	pomacentrid	Chromis verater	x		
Fish	priacanthid	Cookeolus japonicus	x		
Fish	priacanthid	Priacanthus alalaua	x		
Fish	priacanthid	Priacanthus meeki			x
Fish	scorpaenid	Neomerinthes rufescens		x	
Fish	scorpaenid	Portinus macrocephalus	x		
Fish	scorpaenid	Scorpaena colorata			x
Fish	scorpaenid	scorpaenid white		x	
Fish	scorpaenid	Scorpaenodes corallinus			x
Fish	scorpaenid	Scorpaenopsis altirostris?			x
Fish	scorpaenid	Setarches guentheri	x		
Fish	serranid	Caprodon unicolor	x		
Fish	serranid	Epinephelus quermus	x		
Fish	serranid	Holanthias elizabethae	x		
Fish	serranid	Holanthias fuscipinnis	x		
Fish	serranid	Liopropoma aurora	x		
Fish	serranid	Liopropoma maculatus	x		
Fish	serranid	Luzonichthys earlei	x		
Fish	serranid	Plectranthias helenae	x		
Fish	serranid	Plectranthias kelloggi	x		
Fish	serranid	Pseudanthias bicolor	x		
Fish	serranid	Pseudanthias fucinus	x		
Fish	serranid	Pseudanthias thompsoni	x		
Fish	squalid	Squalus mitsukurini			x
Fish	sternoptychid	Araiophos gracilis		x	
Fish	sternoptychid	Argyripnus sp	x		
Fish	symphysanodontid	Symphysanodon maunaloae	x		
Fish	symphysanodontid	Symphysanodon typus	x		
Fish	synodontid	Synodus falcatus			x
Fish	synodontid	Synodus sp	x		
Fish	tetraodontid	Canthigaster epilampra		x	
Fish	tetraodontid	Canthigaster inframacula	x		
Fish	tetraodontid	Canthigaster rivulata		x	
Fish	tetraodontid	Sphoeroides pachygaster			x
Fish	trachichthyid	Aulotrachichthys heptalepis?			x
Fish	trachichthyid	Hoplostethus crassispinus	x		
Fish	trchiurid	trchiurid			x
Fish	triglid	Satyrichthys engyceros	x		
Fish	triglid	Satyrichthys hians		x	
Fish	zeid	Cyttomimus stelgis	x		

8.12 Appendix 12: Bait Study

7/12/2005 Drop 1								
Measurement	Distance From Bottom (m)	Current Speed			Horizontal Spreading		Horizontal Spreading	
		Average	Standard Deviation		Average Rate (mm/s)	Standard Deviation	Rate (mm/s)	Standard Deviation
Aanderra	3.0	0.07	0.02					
VMS	3.5	0.05	0.06		-10.54	36.36	na	na
Aanderra	6.6	0.07	0.02					
Sontek	12.0	0.17	0.09					
Sontek	22.0	0.21	0.09					
Sontek	32.0	0.22	0.09					
Sontek	42.0	0.26	0.10					
Sontek	52.0	0.26	0.12					
Sontek	62.0	0.27	0.10					
Sontek	72.0	0.35	0.11					
Sontek	82.0	0.22	0.12					
Sontek	92.0	0.26	0.12					
7/12/2005 Drop 2								
Measurement	Distance From Bottom (m)	Current Speed			Horizontal Spreading		Horizontal Spreading	
		Average	Standard Deviation		Average Rate (mm/s)	Standard Deviation	Rate (mm/s)	Standard Deviation
Aanderra	3.0	0.20	0.02					
VMS	3.5	0.16	na		na	na	na	na
Aanderra	6.6	0.23	0.02					
Sontek	12.0	0.16	0.11					
Sontek	22.0	0.16	0.08					
Sontek	32.0	0.17	0.09					
Sontek	42.0	0.29	0.10					
Sontek	52.0	0.26	0.11					
Sontek	62.0	0.23	0.13					
Sontek	72.0	0.27	0.11					
Sontek	82.0	0.31	0.17					
Sontek	92.0	0.25	0.16					
7/13/2005 Drop 2								
Measurement	Distance From Bottom (m)	Current Speed			Horizontal Spreading		Horizontal Spreading	
		Average	Standard Deviation		Average Rate (mm/s)	Standard Deviation	Rate (mm/s)	Standard Deviation
Aanderra	3.0	0.23	0.01					
VMS	3.5	0.20	0.05		3.24	39.78	6.19	38.39
Aanderra	6.6	0.11	0.01					
Sontek	12.0	0.29	0.12					
Sontek	22.0	0.29	0.11					
Sontek	32.0	0.28	0.10					
Sontek	42.0	0.24	0.12					
Sontek	52.0	0.16	0.05					
Sontek	62.0	0.15	0.09					
Sontek	72.0	0.21	0.10					
Sontek	82.0	0.24	0.11					
Sontek	92.0	0.22	0.11					

7/13/2005 Drop 3								
Measurement	Distance From Bottom (m)	Current Speed			Horizontal Spreading		Horizontal Spreading	
		Average	Standard Deviation		Average Rate (mm/s)	Standard Deviation	Rate (mm/s)	Standard Deviation
Aanderra	3.0	0.11	0.01					
VMS	3.5	0.07	0.17		-59.64	486.93	na	na
Aanderra	6.6	0.11	0.02					
Sontek	12.0	0.24	0.12					
Sontek	22.0	0.25	0.12					
Sontek	32.0	0.21	0.09					
Sontek	42.0	0.21	0.10					
Sontek	52.0	0.23	0.11					
Sontek	62.0	0.22	0.11					
Sontek	72.0	0.26	0.10					
Sontek	82.0	0.29	0.11					
Sontek	92.0	0.34	0.13					
7/13/2005 Drop 4								
Measurement	Distance From Bottom (m)	Current Speed			Horizontal Spreading		Horizontal Spreading	
		Average	Standard Deviation		Average Rate (mm/s)	Standard Deviation	Rate (mm/s)	Standard Deviation
Aanderra	3.0	0.11	0.03					
VMS	3.5	0.09	0.05		9.83	21.02	11.2	24.86
Aanderra	6.6	0.12	0.07					
Sontek	12.0	0.22	0.19					
Sontek	22.0	0.27	0.21					
Sontek	32.0	0.23	0.13					
Sontek	42.0	0.27	0.16					
Sontek	52.0	0.33	0.25					
Sontek	62.0	0.36	0.24					
Sontek	72.0	0.45	0.27					
Sontek	82.0	0.47	0.30					
Sontek	92.0	0.53	0.44					
Aanderra:								
Data collected for each deployment for 5 minutes before and 5 minutes after bait released								
Continuous 18 second averaging								
Statistical Precision: 0.5 cm/s								
Standard Deviation Reported: Variation in Measurements over 10 minute period								
Sontek:								
Data collected for each deployment for 5 minutes before and 5 minutes after bait released								
2 meter bins								
18 second averaging, 1 minute intervals								
5 bins averaged to get reported value (10 meter depth average reported)								
Velocity Accuracy: 1% of reported value								
Standard Deviation Reported: Variation in Measurements over 10 minute period								

Current Speeds 7/12/05 Drop 1

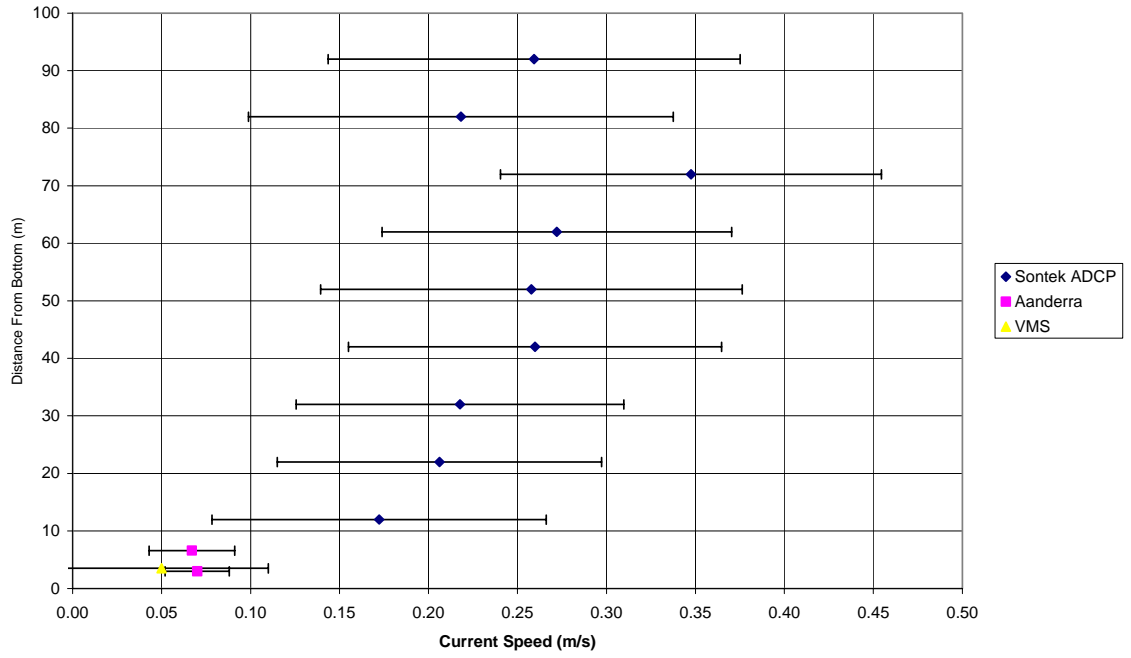

Current Speeds 7/12/05 Drop 2

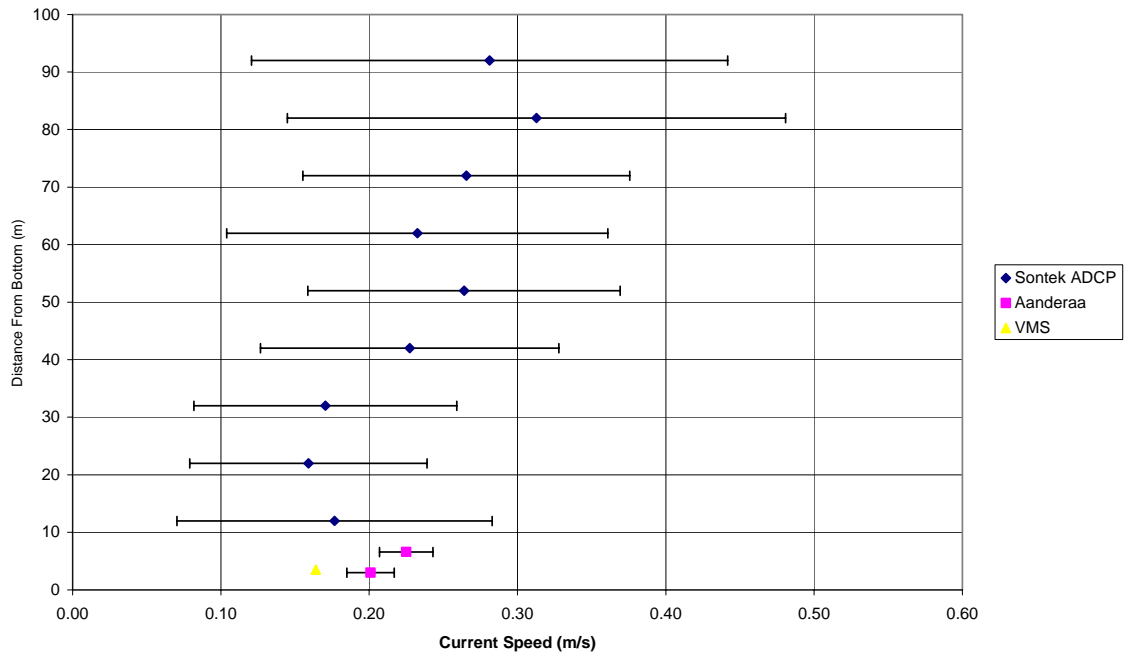

Current Speeds 7/13/05 Drop 2

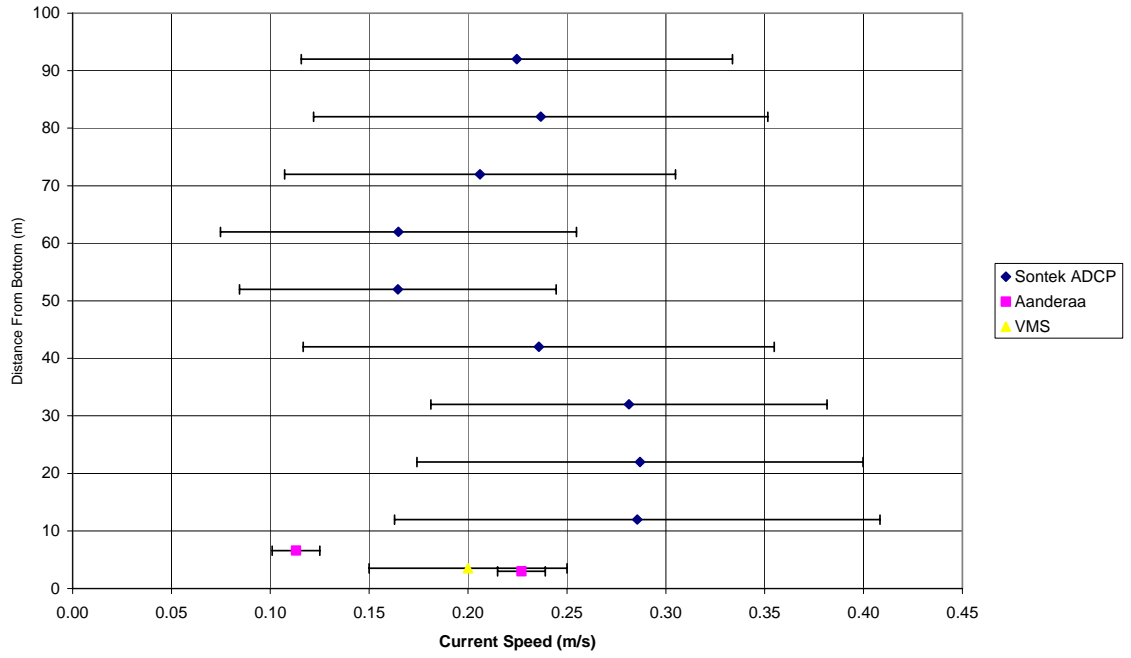

Current Speeds 7/13/05 Drop 3

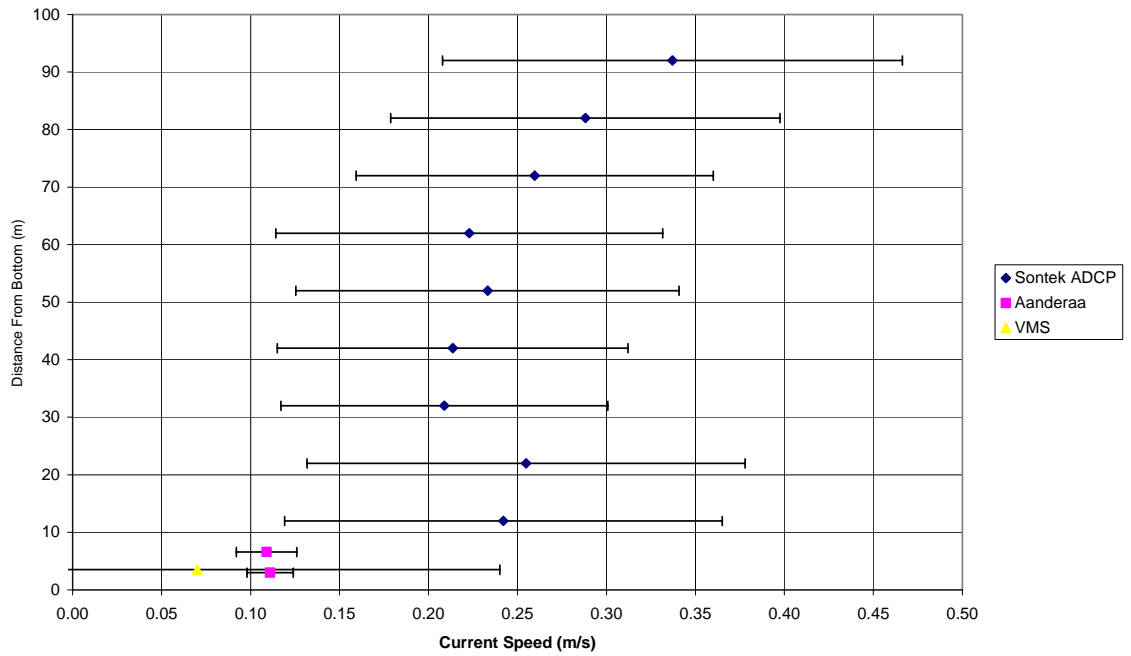

Current Speeds 7/13/05 Drop 4

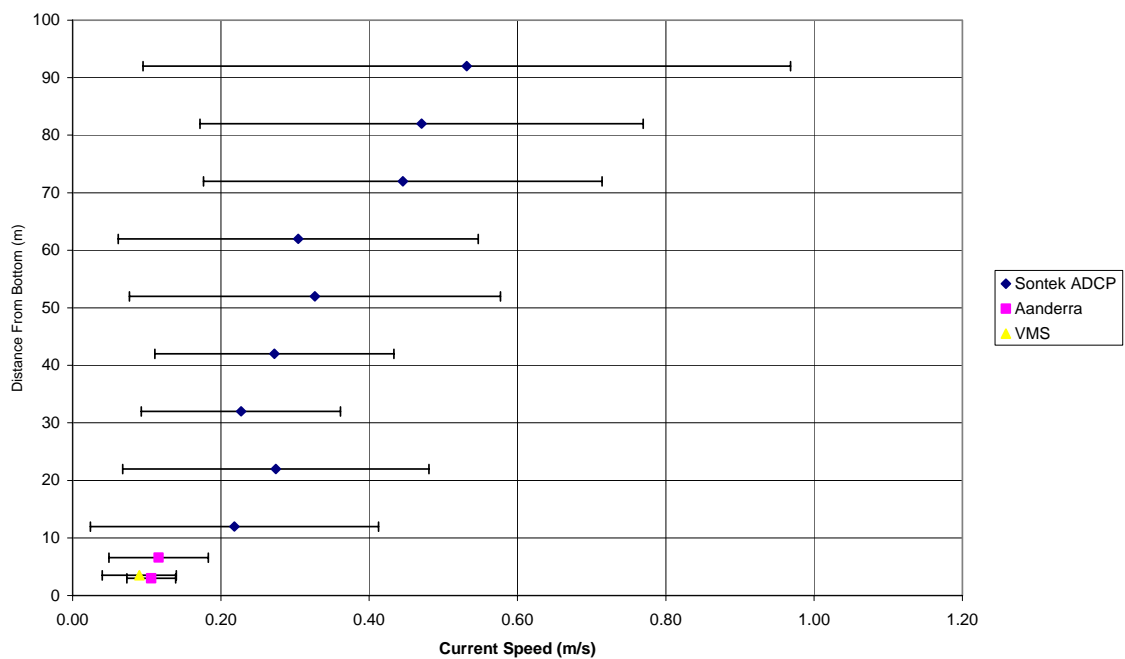

9.0 BIBLIOGRAPHY

9.1 Works Cited

- Cappo, M., Harvey, E., Malcolm, H., and Speare, P. (2002). Potential of video techniques to monitor diversity, abundance and size of fish in studies of marine protected areas. *ASFB Australia 2003*.
- Clauser, F.H. (1956). The Turbulent Boundary Layer. *Advanced Applied Mechanics 4*: 1-51.
- Ellis, D. M., & DeMartini, E. E. (1995). Evaluation of a video camera technique for indexing abundances of juvenile pink snapper, *pristipomoides filamentosus*, and other hawaiian insular shelf fishes. *Fishery Bulletin*, 93(1), 67-77.
- Fox, R.W. and A.T. McDonald. Introduction to Fluid Mechanics. John Wiley & Sons, Inc. New York. Fourth Edition, 1992.
- Francour, P., Liret, C. & Harvey, E. (1999). Comparison of fish abundance estimates made by remote underwater video and visual census. *Nautralista sicil*. Vol. XXIII, 155-168
- Gingras, M. L., Ventresca, D. A., & McGonigal, R. H. (1998). In-situ videography calibrated with 2 parallel lasers for calculation of fish length. *California Fish and Game*, 84(1), 36-39.
- Gledhill, C., Lyczkowski-Shultz, J., Rademacher, K., Kargard, E., Crist, G., & Grace, M. et al. (1996). In Simmonds E. J., MacIennan D. N.(Eds.), *Evaluation of video and acoustic index methods for assessing reef-fish populations*. London (UK): Academic Press.
- Kelley, C & R. Moffitt (2004). "The impacts of bottom fishing on the Raita and West St. Rogatien Reserve Preservations Areas in the Northwestern Hawaiian Islands Coral Reef Ecosystem Reserve." NOS Final Report.
- Parrish, F. A. (1989). Identification of habitat of juvenile snappers in Hawaii. *Fishery Bulletin*, 87(4), 1001-1005.
- Pawlak, G. (2005). *ORE 641 Environmental Fluid Dynamics Lecture Notes*. University of Hawaii Manoa Ocean and Resources Engineering Department.
- Priede, I.G., & Merrett, N.R. (1996). Estimation of abundance of abyssal demersal fishes; a comparison of data from trawls and baited cameras. *Journal of Fish Biology*, 49 (Supplement A), 207-216.
- Sainte-Marie, B., & Hargrave, B.T. (1987). Estimation of scavenger abundance and distance of attraction to bait. *Marine Biology*, 94, 431-443.
- Somerton, D. & Gledhill, C. (2005). Report of the National Marine Fisheries Service Workshop on Underwater Video Analysis. *August 4-6, 2004*, Alaska Fisheries Science Center. Seattle, WA.

- Willis, T. J., Millar, R. B., & Babcock, R. C. (2000). Detection of spatial variability in relative density of fishes: comparison of visual census, angling, and baited underwater video. *Mar.Ecol.Prog.Ser*, 198, 249-260.
- Wong, K. (2003). *Statement of Work, Remote Camera Bait Station, Revised 06 June, 2003*. Contact: Kevin Wong, Kevin.Wong@noaa.gov, 808-592-7032.
- Wong, K. (2004). *SOSI Remote Camera Bait Station First Article Review*. Contact: Kevin Wong, Kevin.Wong@noaa.gov, 808-592-7032.
- Wong, K. (2005). *Statement of Work, Remote Camera Bait Station, Revised 10 January, 2005*. Contact: Kevin Wong, Kevin.Wong@noaa.gov, 808-592-7032.
- Yoshihara, K. (1997). A fish body length measuring method using an underwater video camera in combination with laser discharge equipment. *Fish.Sci*, 63(5), 676-680.
- Zeller, M. Text Book of Photogrammetry. H.K. Lewis & Co. Ltd. London, 1952.

9.2 Works Referenced

- Allen, M. J., & Mearns, A. J. (1977). In Windom H. L., Duce,R.A. (eds.) (Skidaway Inst. Oceanogr., PO Box 13687, Savannah,G.A.31406, U.S.A.)(Eds.), *Bottom fish populations below 200 meters*.
- Anderson, T. W., DeMartini, E. E., & Roberts, D. A. (1989). The relationship between habitat structure, body size and distribution of fishes at a temperate artificial reef. *Bulletin of Marine Science*, 44(2), 681-697. Boehlert, G. W., & Yoklavich, M. M. (1984). Variability in age estimates in seabastes as a function of methodology, different readers and different laboratories. *California Fish and Game*, 70(4), 210-224.
- Boehlert, G. W., & Yoklavich, M. M. (1983). Effects of temperature, ration, and fish size on growth of juvenile black rockfish, seabastes melanops. *Environmental biology of fishes.The Hague*, 8(1), 17-28.
- Bortone, S. A., Kimmel, J. J., & Bundrick, C. M. (1989). A comparison of three methods for visually assessing reef fish communities: time and area compensated. *Northeast Gulf Sci.*, 10(2), 85-96.
- Bortone, S. A., Martin, T., & Bundrick, C. M. (1991). Visual census of reef fish assemblages: A comparison of slate, audio, and video recording devices. *Northeast Gulf Sci.*, 12(1), 17-23.
- Boucher, E., & Petrell, R. J. (1999). Swimming speed and morphological features of mixed populations of early maturing and non-maturing fish. *Aquacultural Engineering*, 20(1), 21-35.
- Braeger, S., Chong, A., Dawson, S., Slooten, E., & Wuersig, B. (1999). A combined stereo-photogrammetry and underwater-video system to study group composition of dolphins. *Helgoland Marine Research*, 53(2), 122-128.
- Caimi, F. M. (1993). Laser/light imaging for underwater use. *Sea Technology*, 34(12), 22-27.

- Caimi, F. M., Blatt, J. H., Grossman, B. G., Smith, D., Hooker, J., & Kocak, D. M. et al. (1993). Advanced underwater laser systems for ranging, size estimation, and profiling. *Marine Technology Society Journal*, 27(1), 31-41.
- Cappo, M., Brown, I., & Cooperative Research Cent. for the Ecologically Sustainable Development of the Great Barrier Reef, Townsville (Australia). (1996). *Evaluation of sampling methods for reef fish populations of commercial and recreational interest*. Townsville, Qld. (Australia): CRC Reef Research Cent.
- Cappo, M., Harvey, E., Malcolm, H., and Speare, P. (2002). Potential of video techniques to monitor diversity, abundance and size of fish in studies of marine protected areas. *ASFB Australia 2003*.
- Cappo, M., Walters, C. J., & Lenanton, R. C. (2000). Estimation of rates of migration, exploitation and survival using tag recovery data for western australian "salmon" (arripis truttaceus: arripidae: percoidei). *Fisheries Research (Amsterdam)*, 44(3), 207-217.
- Chave, E. H., & Mundy, B. C. (1994). Deep-sea benthic fish of the hawaiian archipelago, cross seamount, and johnston atoll. *Pacific Science*, 48(4), 367-409.
- Chezar, H., & Hagey, W. H. (1994). Microprocessor controlled real-time imaging system. *Sea Technology*, 35(9), 61-64.
- Claireaux, G., & Lefrancois, C. (1998). A method for the external attachment of acoustic tags on roundfish. *Hydrobiologia*, 371-372(1-3), 113-116.
- Clauser, F.H. (1955). The Turbulent Boundary Layer. *Advanced Applied Mechanics* 4: 1-51.
- Collins, M. A., Priede, I. G., & Bagley, P. M. (1999). In situ comparison of activity in two deep-sea scavenging fishes occupying different depth zones. *Proceedings of the Royal Society of London, Series B: Biological Sciences*, 266(1432), 2011-2016.
- Demartini, E. E. (1998). How might recruitment research on coral-reef fishes help manage tropical reef fisheries? *Australian Journal of Ecology*, 23(3), 305-310.
- DeMartini, E. E., & Lau, B. B. (1999). Morphometric criteria for estimating sexual maturity in two snappers, *etelis carbunculus* and *pristipomoides sieboldii*. *Fishery Bulletin*, 97(3), 449-458.
- DeMartini, E. E., Parrish, F. A., & Parrish, J. D. (1996). Interdecadal change in reef fish populations at french frigate shoals and midway atoll, northwestern hawaiian islands: statistical power in retrospect. *Bulletin of Marine Science*, 58(3), 804-825.
- DeMartini, E. E., Roberts, D. A., & Anderson, T. W. (1989). Contrasting patterns of fish density and abundance at an artificial rock reef and a cobble-bottom kelp forest. *Bulletin of Marine Science*, 44(2), 881-892.
- Doucette, J. S., Harvey, E. S., & Shortis, M. R. (2002). Stereo-video observation of nearshore bedforms on a low energy beach. *Marine Geology*, 189(3-4), 289-305.
- Dyer, K.R. (1997). *Estuaries: A Physical Introduction*. John Wiley & Sons, Chichester.

- Ehrenberg, J. E., & Steig, T. W. (2003). Improved techniques for studying the temporal and spatial behavior of fish in a fixed location. *ICES Journal of Marine Science*, 60(3), 700-706.
- Ehrenberg, J. E., & Steig, T. W. (2002). A method for estimating the 'position accuracy' of acoustic fish tags. *ICES Journal of Marine Science*, 59(1), 140-149.
- Ellis, D. M., & DeMartini, E. E. (1995). Evaluation of a video camera technique for indexing abundances of juvenile pink snapper, *pristipomoides filamentosus*, and other hawaiian insular shelf fishes. *Fishery Bulletin*, 93(1), 67-77.
- Fox, R.W. and A.T. McDonald. Introduction to Fluid Mechanics. John Wiley & Sons, Inc. New York. Fourth Edition, 1992.
- Fischer, H.S., List, E.J., Koh, J.L., Imberger, J., Brooks, N. (1979). *Mixing in Inland and Coastal Waters*. Academic Press Inc., San Diego.
- Francour, P., Liret, C. & Harvey, E. (1999). Comparison of fish abundance estimates made by remote underwater video and visual census. *Nautralista sicil*. Vol. XXIII, 155-168
- Friedlander, A. M., & DeMartini, E. E. (2002). Contrasts in density, size, and biomass of reef fishes between the northwestern and the main hawaiian islands: the effects of fishing down apex predators. *Marine Ecology Progress Series*, 230, 253-264.
- Gauthier, S., & Rose, G. A. (2002). In situ target strength studies on atlantic redfish (*sebastes* spp.). *ICES Journal of Marine Science*, 59(4), 805-815.
- Gingras, M. L., Ventresca, D. A., & McGonigal, R. H. (1998). In-situ videography calibrated with 2 parallel lasers for calculation of fish length. *California Fish and Game*, 84(1), 36-39.
- Gledhill, C., Lyczkowski-Shultz, J., Rademacher, K., Kargard, E., Crist, G., & Grace, M. et al. (1996). In Simmonds E. J., MacIennan D. N.(Eds.), *Evaluation of video and acoustic index methods for assessing reef-fish populations*. London (UK): Academic Press.
- Greene, L. E., & Alevizon, W. S. (1989). Comparative accuracies of visual assessment methods for coral reef fishes. *Bulletin of Marine Science*, 44(2), 899-912.
- Gunn, J., & Davis, T. (1994). Computer tuna tag becomes a reality. *Australian Fisheries*, 53(9), 12-14.
- Harvey, E., Cappel, M., Shortis, M., Robson, S., Buchanan, J., & Speare, P. (2003). The accuracy and precision of underwater measurements of length and maximum body depth of southern bluefin tuna (*thunnus maccoyii*) with a stereo-video camera system. *Fisheries Research (Amsterdam)*, 63(3), 315-326.
- Harvey, E., Fletcher, D., & Shortis, M. (2002). Estimation of reef fish length by divers and by stereo-video: A first comparison of the accuracy and precision in the field on living fish under operational conditions. *Fisheries Research (Amsterdam)*, 57(3), 255-265.
- Harvey, E., Fletcher, D., & Shortis, M. (2001). A comparison of the precision and accuracy of estimates of reef-fish lengths determined visually by divers with estimates produced by a stereo-video system. *Fishery Bulletin*, 99(1), 63-71.

- Harvey, E., Fletcher, D., & Shortis, M. (2001). Improving the statistical power of length estimates of reef fish: a comparison of estimates determined visually by divers with estimates produced by a stereo-video system. *Fishery Bulletin*, 99(1), 72-80.
- Harvey, E. & Shortis, M. (1995). A System for Stereo-Video Measurement of Sub-Tidal Organisms. *MTS Journal*, Vol. 29, No. 4.
- Harvey, E., Shortis, M., Stadler, M., & Cappel, M. (2002). A comparison of the accuracy and precision of measurements from single and stereo-video systems. *Marine Technology Society Journal*, 36(2), 38-49.
- Holland, K. T., Holman, R. A., Lippmann, T. C., Stanley, J., & Plant, N. (1997). Practical use of video imagery in nearshore oceanographic field studies. *IEEE Journal of Oceanic Engineering*, 22(1), 81-92.
- Hughes, N. F., & Kelly, L. H. (1996). New techniques for 3-D video tracking of fish swimming movements in still or flowing water. *Canadian journal of fisheries and aquatic sciences/Journal canadien des sciences halieutiques et aquatiques*. Ottawa ON, 53(11), 2473-2483.
- Irvine, J. R., Ward, B. R., Teti, P. A., & Cousens, N. B. F. (1991). Evaluation of a method to count and measure live salmonids in the field with a video camera and computer. *North American Journal of Fisheries Management*, 11(1), 20-26.
- Karplus, I., Gottdiener, M., & Zion, B. (2003). Guidance of single guppies (*poecilia reticulata*) to allow sorting by computer vision. *Aquacultural Engineering*, 27(3), 177-190.
- Kelley, C & R. Moffitt (2004). "The impacts of bottom fishing on the Raita and West St. Rogatien Reserve Preservations Areas in the Northwestern Hawaiian Islands Coral Reef Ecosystem Reserve." NOS Final Report.
- Krohn, M. M., & Boisclair, D. (1994). Use of a stereo-video system to estimate the energy expenditure of free-swimming fish. *Canadian Journal of Fisheries and Aquatic Sciences*, 51(5), 1119-1127.
- Kubecka, J., & Wittingerova, M. (1998). Horizontal beaming as a crucial component of acoustic fish stock assessment in freshwater reservoirs. *Fisheries Research (Amsterdam)*, 35(1-2), 99-106.
- Lawson, G. L., & Rose, G. A. (1999). The importance of detectability to acoustic surveys of semi-demersal fish. *ICES Journal of Marine Science*, 56(3), 370-380.
- Li, R., Li, H., Smith, R., & Curran, T. Quantitative analysis of underwater stereo video images. Vancouver, BC (Canada),
- Love, M. S., Caselle, J. E., & van Buskirk, W. (1998). A severe decline in the commercial passenger fishing vessel rockfish (*sebastes* spp.) catch in the southern california bight, 1980-1996. *Reports of California Cooperative Oceanic Fisheries Investigations*, 39, 180-195.
- Love, M. S., & Johnson, K. (1999). Aspects of the life histories of grass rockfish, *sebastes rastrelliger*, and brown rockfish, *S. auriculatus*, from southern california. *Fishery Bulletin*, 97(1), 100-109.

- Mackay, D. (1996). Underwater cameras -- SIT or CCD? *Sea Technology*, 37(9), 35-38.
- Marriott, R., & Cappel, M. (2000). Comparative precision and bias of five different ageing methods for the large tropical snapper *Lutjanus johnii*. *Asian fisheries science*, 13(2), 149-160.
- Moffitt, R. B., & Parrish, F. A. (1996). Habitat and life history of juvenile hawaiian pink snapper, *pristipomoides filamentosus*. *Pacific Science*, 50(4), 371-381.
- Moffitt, R. B., & Parrish, F. A. (1992). An assessment of the exploitable biomass of *heterocarpus laevigatus* in the main hawaiian islands. part 2: observations from a submersible. *Fishery Bulletin*, 90(3), 476-482.
- Moffitt, R. B., Parrish, F. A., & Polovina, J. J. (1989). Community structure, biomass and productivity of deepwater artificial reefs in hawaii. *Bulletin of Marine Science*, 44(2), 616-630.
- Naiberg, A., Petrell, R., Savage, C., & Neufeld, T. (1993). In Wang J. -. (Ed.), *A non-invasive fish size assessment method for tanks and sea cages using stereo video*. St. Joseph, MI (USA): American Society of Agricultural Engineers.
- Niemann, H. R., Aust, E., Gustmann, M., Hahn, G., & GKSS - Forschungszent. Geesthacht GmbH, Geesthacht-Tesperhude (FRG). (1992). *Six DOF robot allows diverless intervention* (Q2 02302 Underwater vehicles No. GKSS-92/E/44, CONF-9211214-1) August 13, 2004, from ASFA: Aquatic Sciences and Fisheries Abstracts database.
- Parker, S. J., Berkeley, S. A., Golden, J. T., Gunderson, D. R., Heifetz, J., & Hixon, M. A. et al. (2000). Management of pacific rockfish. *Fisheries*, 25(3), 22-30.
- Parrish, F. A. (1989). Identification of habitat of juvenile snappers in hawaii. *Fishery Bulletin*, 87(4), 1001-1005.
- Parrish, F. A., DeMartini, E. E., & Ellis, D. M. (1997). Nursery habitat in relation to production of juvenile pink snapper, *pristipomoides filamentosus*, in the hawaiian archipelago. *Fishery Bulletin*, 95(1), 137-148.
- Pawlak, G. (2005). *ORE 641 Environmental Fluid Dynamics Lecture Notes*. University of Hawaii Manoa Ocean and Resources Engineering Department.
- Petrell, R. J. (2001). Underwater cameras in aquaculture part 1: fish sizing and monitoring. *Aquaculture Magazine*, 27(1), 42-44.
- Petrell, R. J. (2001). Underwater cameras in aquaculture part 2: monitoring fish feeding. *Aquaculture Magazine*, 27(2), 72-74.
- Petrell, R. J., Shi, X., Ward, R. K., Naiberg, A., & Savage, C. R. (1997). Determining fish size and swimming speed in cages and tanks using simple video techniques. *Aquacultural Engineering*, 16(1-2), 63-84.
- Priede, I.G., & Merrett, N.R. (1996). Estimation of abundance of abyssal demersal fishes; a comparison of data from trawls and baited cameras. *Journal of Fish Biology*, 49 (Supplement A), 207-216.

- Royce-Malmgren, C. H., & Watson, W. H., III. (1987). An interactive video-computer tracking system for quantification of locomotor behavior. *Journal of chemical ecology*, 13(5), 1029-1044.
- Shevelev, M., Mamylov, V., Ratushny, S., Gavrilov, E., Northwest Atlantic Fisheries Organ. Dartmouth, NS (Canada), & Northwest Atlantic Fisheries Organ., Dartmouth, NS (Canada). (1998). In Shevelev M. S., Mamylov V. S., Ratushny S. V. and Gavrilov E. N.(Eds.), *Technique of russian bottom trawl and acoustic surveys of the barents sea and how to improve them*.
- Shieh, A. C. R., & Petrell, R. J. (1998). Measurement of fish size in atlantic salmon (*salmo salar* L.) cages using stereographic video techniques. *Aquacultural Engineering*, 17(1), 29-43.
- Sainte-Marie, B., & Hargrave, B.T. (1987). Estimation of scavenger abundance and distance of attraction to bait. *Marine Biology*, 94, 431-443.
- Somerton, D. & Gledhill, C. (2005). Report of the National Marine Fisheries Service Workshop on Underwater Video Analysis. *August 4-6, 2004*, Alaska Fisheries Science Center. Seattle, WA.
- Tipping, J. M. (1994). Measuring fish by video image processing. *Progressive Fish-Culturist*, 56(4), 299-300.
- Willis, T. J. (2001). Visual census methods underestimate density and diversity of cryptic reef fishes. *Journal of fish biology*, 59(5), 1408-1411.
- Willis, T. J., Millar, R. B., & Babcock, R. C. (2000). Detection of spatial variability in relative density of fishes: comparison of visual census, angling, and baited underwater video. *Mar.Ecol.Prog.Ser*, 198, 249-260.
- Willis, T. J., Parsons, D. M., & Babcock, R. C. (2001). Evidence for long-term site fidelity of snapper (*pagrus auratus*) within a marine reserve. *New Zealand Journal of Marine and Freshwater Research*, 35(3), 581-590.
- Wilson, R. R., Jr, & Smith, K. L., Jr. (1984). Effect of near-bottom currents on detection of bait by the abyssal grenadier fishes *coryphaenoides* spp., recorded in situ with a video camera on a free vehicle. *Marine biology.Berlin, Heidelberg*, 84(1), 83-91.
- Winger, P. D., McCallum, B. R., Walsh, S. J., & Brown, J. A. (2002). Taking the bait: in situ voluntary ingestion of acoustic transmitters by atlantic cod (*gadus morhua*). *Hydrobiologia*, 483(1-3), 287-292.
- Wong, K. (2003). *Statement of Work, Remote Camera Bait Station, Revised 06 June, 2003*. Contact: Kevin Wong, Kevin.Wong@noaa.gov, 808-592-7032.
- Wong, K. (2004). *SOSI Remote Camera Bait Station First Article Review*. Contact: Kevin Wong, Kevin.Wong@noaa.gov, 808-592-7032.
- Wong, K. (2005). *Statement of Work, Remote Camera Bait Station, Revised 10 January, 2005*. Contact: Kevin Wong, Kevin.Wong@noaa.gov, 808-592-7032.

- Yau, Y.A., Collins, M.A., Bagley, P.M., Everson, I., Nolan, C.P. & Priede, I.G. (2001). Estimating the abundance of Patagonian toothfish *Dissostichus eleginoides* using baited cameras: a preliminary study. *Fisheries Research* 51, 403-412.
- Yoklavich, M. M., Greene, H. G., Cailliet, G. M., Sullivan, D. E., Lea, R. N., & Love, M. S. (2000). Habitat associations of deep-water rockfishes in a submarine canyon: an example of a natural refuge. *Fishery Bulletin*, 98(3), 625-641.
- Yoshihara, K. (1997). A fish body length measuring method using an underwater video camera in combination with laser discharge equipment. *Fish. Sci*, 63(5), 676-680.
- Zeller, M. Text Book of Photogrammetry. H.K. Lewis & Co. Ltd. London, 1952.
- Zion, B., Shklyar, A., & Karplus, I. (2000). In-vivo fish sorting by computer vision. *Aquacult.Eng*, 22(3), 165-179.